

# T ECHNICAL INFORMATION



PRODUCT

P 1 / 37

**Models No.** ▶ LS1016, LS1016L

**Description** ▶ Slide Compound Miter Saw 255mm (10")\*1/ 260mm (10-1/4")  
[\*1 255mm (1") for North America]

## CONCEPT AND MAIN APPLICATIONS

LS1016 and LS1016L are upgraded sister tools of LS1013 series models, featuring DXT (Deep eXact cutting Technology) achieved by our consistent pursuit of cutting larger size workpiece but with higher accuracy.

The features and benefits of DXT are:

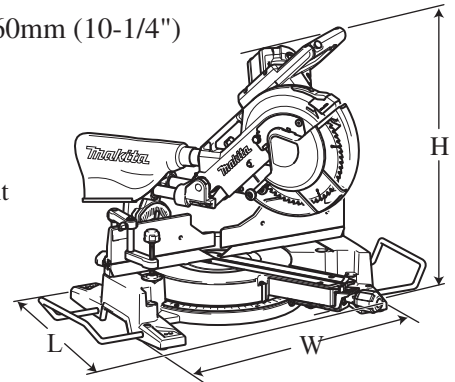
### Deep cutting

3-Stage reduction gear unit and Movable rear blade guard provide larger capacities of cutting Crown molding and Baseboard (Skirt board) which are typical workpieces of slide compound miter saws.

### eXact cutting

Precise and exact cutting obtained by employing:

- Double sliding mechanism
- Double sliding guide fence
- Quick and accurate miter angle lock, etc



Dimensions: mm (")	
Length (L)	718 (28-1/4)
Width (W)	640 (25-1/4)
Height (H)	671 (26-1/2)

LS1016L additionally features laser marker for easy cut line alignment.

## ► Specification

Voltage (V)	Current (A)	Cycle (Hz)	Continuous Rating (W)		Max. Output (W)
			Input	Output	
110	15	50/60	1,510	900	2,600
120	15	50/60	---	900	2,600
220	7.2	50/60	1,510	800	2,000
230	6.9	50/60	1,510	800	2,000
240	6.6	50/60	1,510	800	2,000

Specification		Model No.	LS1016	LS1016L
No load speed: min <sup>-1</sup> = rpm			3,200	
Saw blade: mm (")	Diameter		250 (9-7/8) - 260 (10-1/4)	
	Hole diameter		European countries: 30, North America: 15.88 (5/8), Other countries: 25.4 (1)	
Electric brake			Yes	
Electronic control	Soft start		Yes	
	Constant speed		Yes	
Laser marker			No	Yes
Lock-off switch			Yes	
Protection against electric shock			Double insulation	
Cord length: m (ft)			2.5 (8.2)	
Net weight*2: kg (lbs)			24.1 (53.1)	24.2 (53.3)
Net weight*3: kg (lbs)			23.6 (52.0)	23.7 (52.2)

\*2 Weight according to EPTA-Procedure 01/2003, with TCT saw blade and "Blocking mechanism at the rest position"

\*3 With TCT saw blade, without "Blocking mechanism at the rest position"

See next page for the cutting capacities.

## ► Standard equipment

Vertical vise .....	1	Triangular rule .....	1
TCT saw blade .....	1	Spare lock-off button .....	2
Dust bag .....	1	Holder set .....	2 (all countries except North America)
Socket wrench 13 .....	1	Hex wrench .....	1 (LS1016L only)

**Note:** The standard equipment for the tool shown may differ by country.

## ► Optional accessories

Horizontal vise	TCT saw blades	Crown molding stopper set
Dust box	Portable miter saw stand	

► **Specification (cont.)**

**[Cutting Capacities]**

**North America**

**Cutting capacities [Height x Width in mm (")]**  
**with 255mm (10") saw blade**

Bevel angle Miter angle	45 degrees left	0 degree	45 degrees right
0 degree	47 x 305 (1-7/8 x 12) 61 x 279 (2-3/8 x 11)	71 x 305 (2-13/16 x 12) 91 x 279 (3-5/8 x 11)	29 x 305 (1-1/8 x 12) 43 x 279 (1-11/16 x 11)
45 degrees left & right	47 x 215 (1-7/8 x 8-1/2) 61 x 197 (2-3/8 x 7-3/4)	71 x 215 (2-13/16 x 8-1/2) 91 x 197 (3-5/8 x 7-3/4)	29 x 215 (1-1/8 x 8-1/2) 43 x 197 (1-11/16 x 7-3/4)
52 degrees left & right		71 x 187 (2-13/16 x 7-3/8) 91 x 171 (3-5/8 x 6-3/4)	
60 degrees right		71 x 152 (2-13/16 x 6) 91 x 139 (3-5/8 x 5-1/2)	

**All countries except North America**

**Cutting capacities [Height x Width in mm]**  
**with 260mm (10-1/4") saw blade**

Bevel angle Miter angle	45 degrees left	0 degree	45 degrees right
0 degree	42 x 310 58 x 279	68 x 310 91 x 279	29 x 310 43 x 279
45 degrees left & right	42 x 218 58 x 197	68 x 218 91 x 197	29 x 218 43 x 197
52 degrees left & right		68 x 190 91 x 171	
60 degrees right		68 x 155 91 x 139	

**All countries**

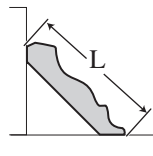
**Capacities of cutting Crown molding and Baseboard (Skirt board)**  
**with 255mm (10") or 260mm (10-1/4") saw blade at 0 degree/ 0 degree**

Workpiece	How to cut	Capacity: mm (")
Crown molding, 45 degree type	Diagonal cut*	168 (6-5/8)**
Baseboard (Skirt board)	Vertical cut***	120 (4-3/4)

\* Diagonal cut is to cut a crown molding that is held tilted against the guide fence using Crown molding stopper.

\*\* The capacity of crown molding diagonal cut is the length L shown in the drawing on right.

\*\*\*Vertical cut is to cut a baseboard (skirt board) that is clamped with Horizontal vise.



## ► Repair

**CAUTION: Unplug the tool and remove the saw blade from the machine for safety before repair/ maintenance in accordance with the instruction manual!**

### [1] NECESSARY REPAIRING TOOLS

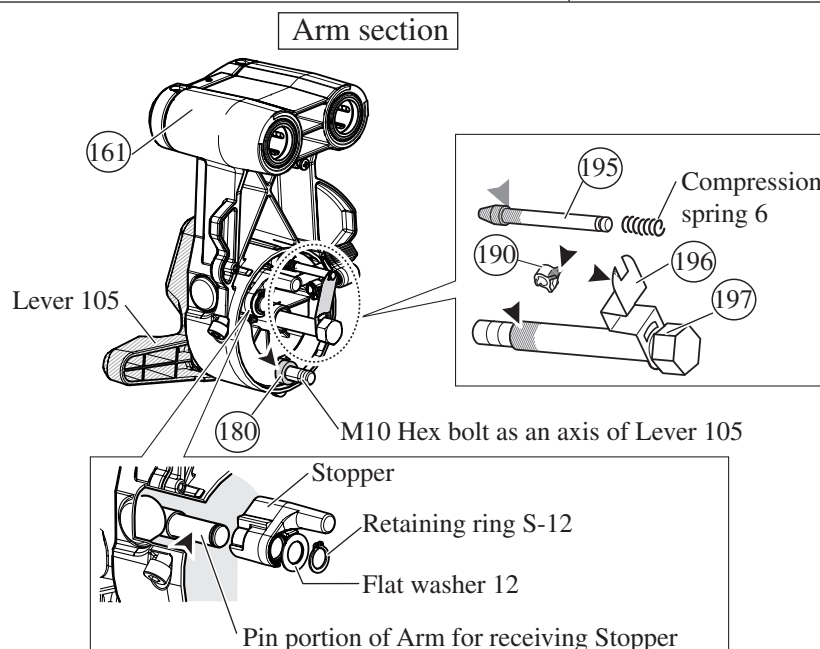
Code No.	Description	Use for
1R028	Bearing setting pipe 20-12.2	Mounting Retaining ring S-12
1R031	Bearing setting pipe 28-12.2	Mounting Helical gear 27
1R034	Bearing setting plate 12.2	Mounting Helical gear 27
1R036	Bearing setting plate 17.2	Mounting Helical gear 28
1R045	Gear extractor (large)	Mounting / Removing Helical gear 14
1R207	45-degree set square	Adjusting the bevel angle of Saw blade to 45 degree
1R208	90-degree set square	Adjusting the bevel angle of Saw blade to 90 degree
1R217	Ring 22	Removing Helical gear 27
1R220	Ratchet head 27	Attachment for 1R254
1R222	Socket adapter	Attachment for 1R254
1R232	Pipe 30	Mounting Helical gear 28
1R254	Torque wrench shaft 2 - 6 N.m	Tightening Hex lock nut M10-17
1R269	Bearing extractor (small)	Removing Ball bearings
1R291	Retaining ring S and R pliers	Removing Retaining ring in Gear section
1R315	Laser beam positioning jig	Adjusting Laser beam
1R346	Center attachment	Attachment for 1R045
1R361	Bearing retainer wrench 14-23	Mounting / Removing Bearing retainer wrench 14-23
253771-0	Flat washer 16	Adjusting Laser beam
134829-3	Socket 17-38 assembly	Attachment for 1R254
782232-8	Box wrench 13 (standard accessory)	Installing /Removing Blade Adjusting Blade position

### [2] LUBRICATIONS

Apply Lubricants to the designated portions in order to protect parts and product from unusual abrasion.

Item No.	Description	Portion to lubricate	Lubricant	Amount
(161)	Arm complete	Pin portion for receiving Stopper	Makita grease SG.No.00 designated with ▼	a little
(180)	Rubber ring 9	Whole portion		
(190)	Cam	Tip portion which contacts with (196) Leaf spring		
(195)	Lock pin 8	Portion where Compression spring 6 contacts	VG100 designated with ▼	
(196)	Leaf spring	Surface where (195) and Compression spring 6 contact	Makita grease SG.No.00 designated with ▼	
(197)	Center shaft	Portion where Arm's hole without thread contacts		

**Fig. 4**



## ► Repair

### [2] LUBRICATIONS (cont.)

Apply Makita grease SG.No.00 to the following portions designated with the black triangle to protect parts and product from unusual abrasion.

Item No.	Description	Portion to lubricate
(97)	Torsion Spring 45	Loop portion
(102)	Center washer	Portion where Center cover contacts
(103)	Center plate	Portion where Center cover contacts
(136) (143)	Lower fence	a. Portion where Pin 4 contacts
(138)	Guide fence	b. Portion where Lower fence contacts
(63)	Blade case	Pivot portion which contacts with Front arm
(149)	Sleeve 17	Drum portion
(150)	Rod 16	Drum portion
(152)	O ring 5	Whole portion

Fig. 2

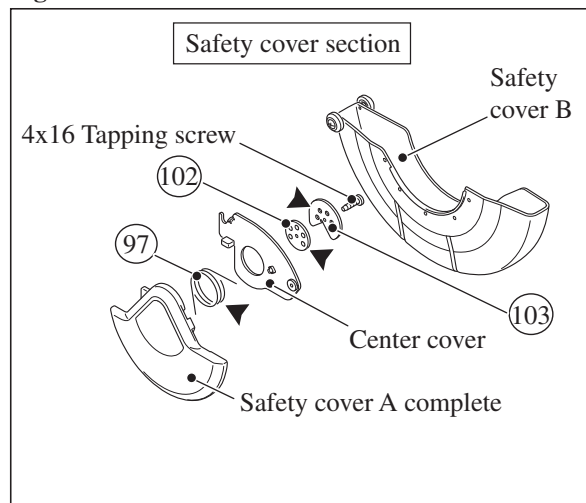


Fig. 3

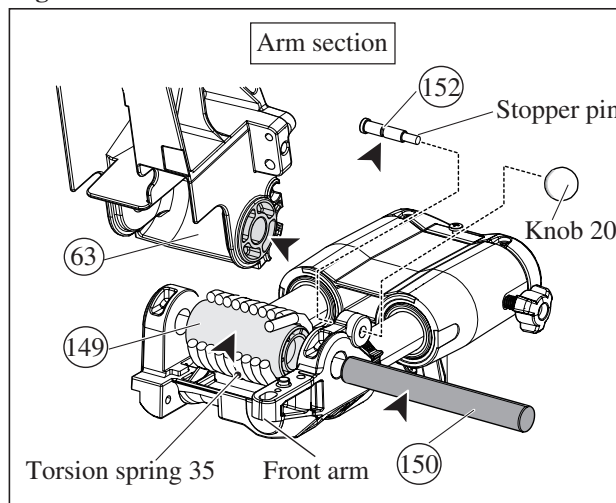
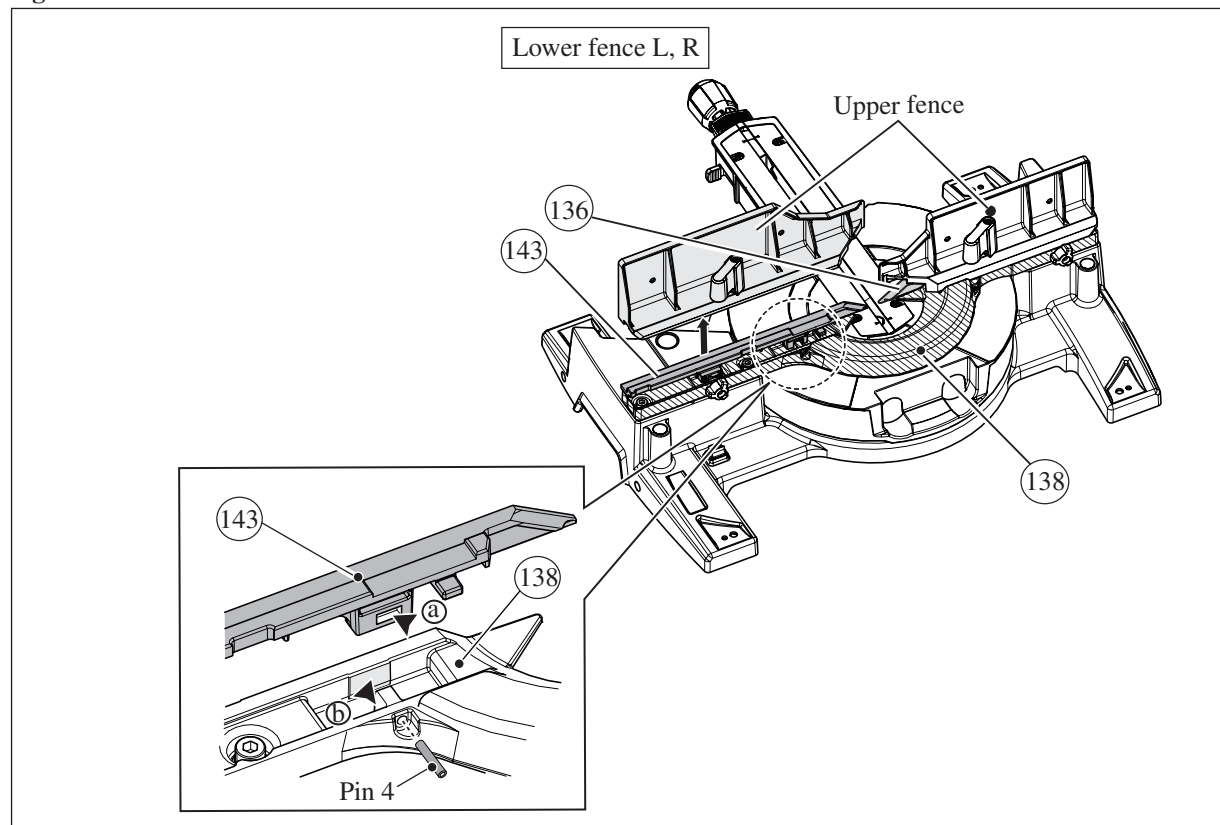


Fig. 4



► **Repair**

[2] LUBRICATIONS (cont.)

Apply **Makita grease SG.No.00** to the following portions designated with **the black triangle** to protect parts and product from unusual abrasion.

Item No.	Description	Portion to lubricate	Amount
(14)	Armature	Gear shaft portion for smooth engaging with Spiral bevel gear 32	15g
(53)	Link plate	Link plate's hole with which Rubber pin contacts	a little
(80)	Helical gear 28	Teeth portion for smooth engaging with Helical gear 27	8g
(207)	Turn base	Rib which is on the opposite side of Turn base	a little
(210)	Rack block	Its teeth portion for smooth engaging with Spur gear 34	
(228)	Miter lock plate	Surface where Cam portion of Grip 50 contacts.	
(242)	Base	Hole for pivoting of Turn base	
(248)	Slide plate	Surface on which (207) Turn base moves	

Fig. 5

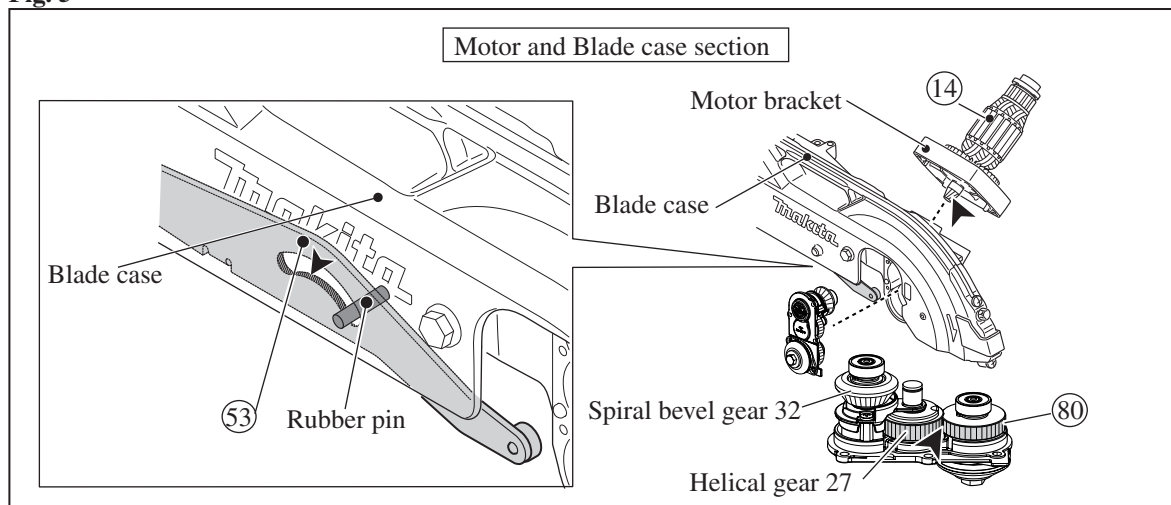
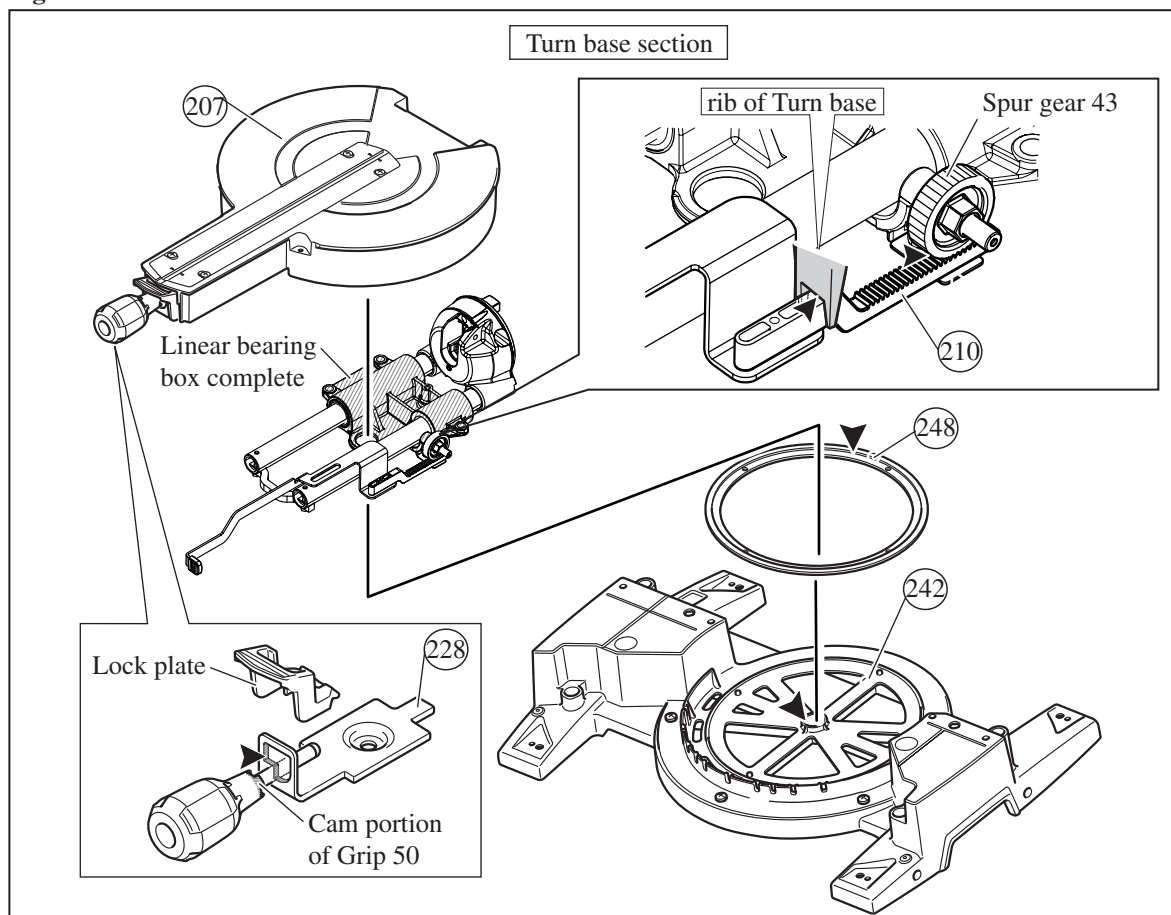


Fig. 6



► **Repair**

**[3] DISASSEMBLY/ASSEMBLY**

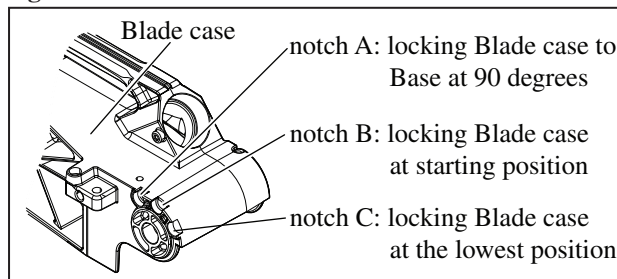
**[3]-1. Blade case, Motor section**

**DISASSEMBLING**

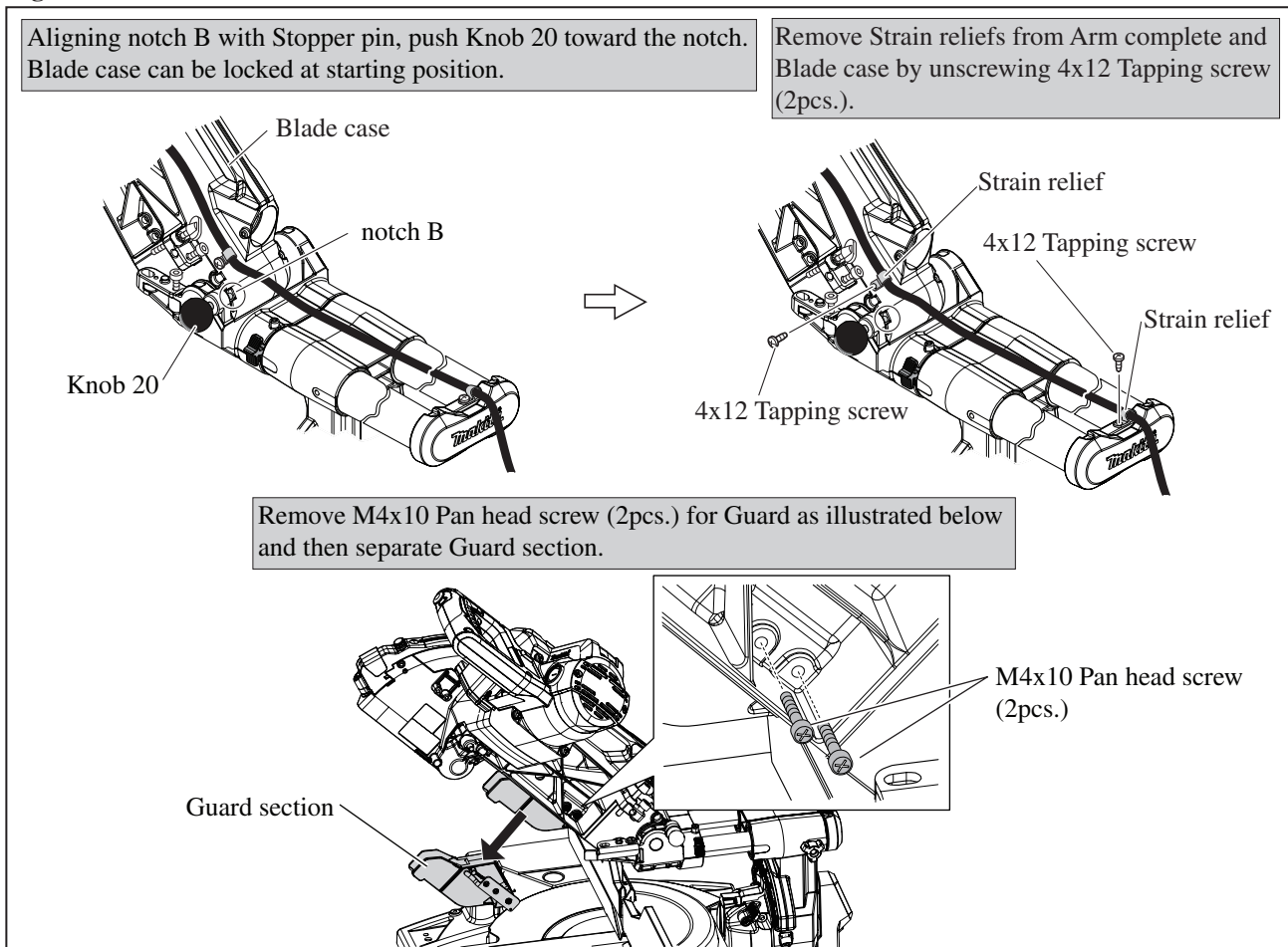
**Note:** Refer to **Fig. 7**. The three notches on Blade case have important role for disassembly / assembly.

(1) Disconnect the linkage of Blade case with Arm and Base section by removing Strain relief and Link plate as illustrated in **Figs. 8 and 9**.

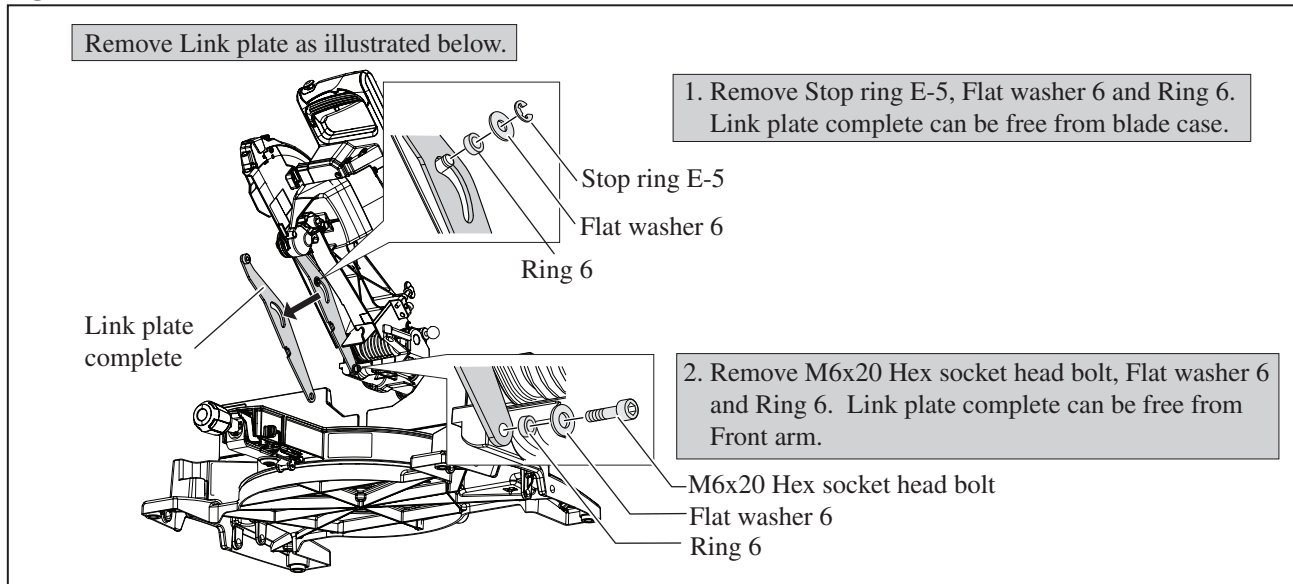
**Fig. 7**



**Fig. 8**



**Fig. 9**



► **Repair**

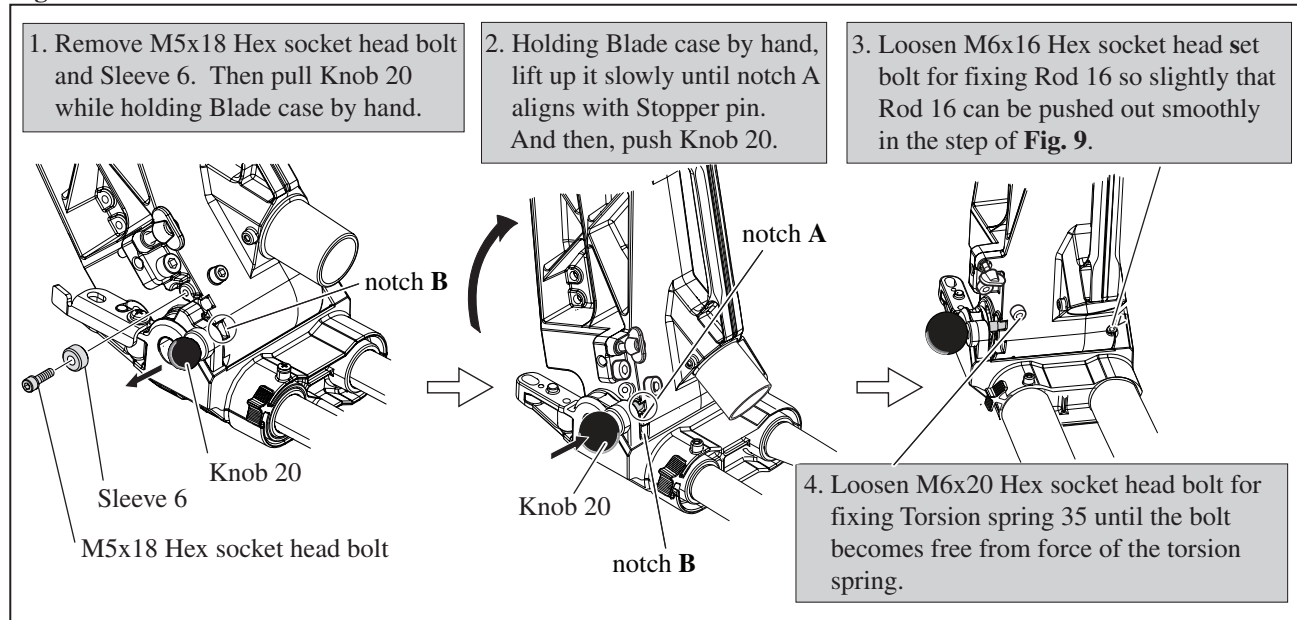
**[3] DISASSEMBLY/ASSEMBLY**

**[3]-1. Blade case, Motor section (cont.)**

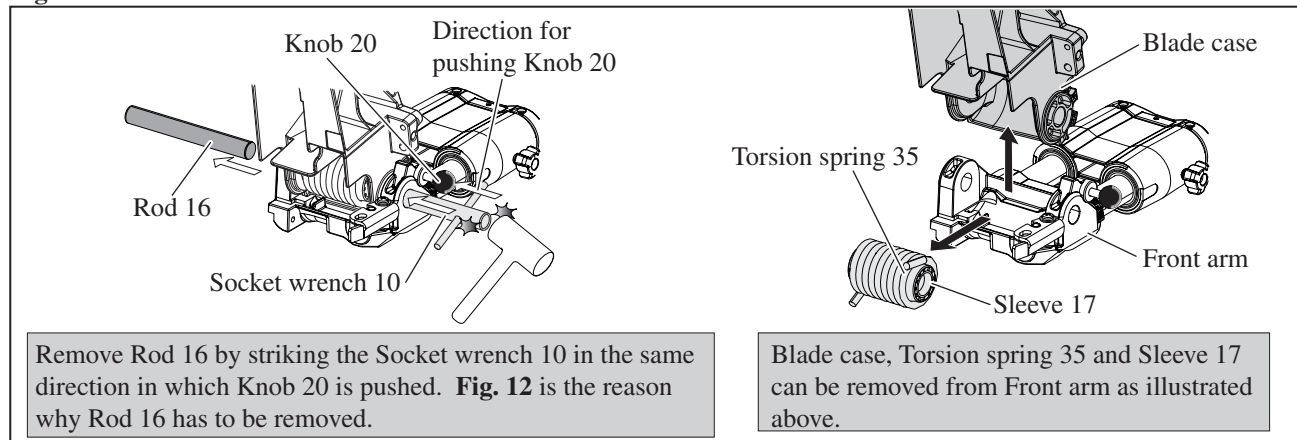
**DISASSEMBLING**

(2) Remove Rod 16 as illustrated in **Figs. 10 and 11**. Blade case can be separated from Arm and Base section.

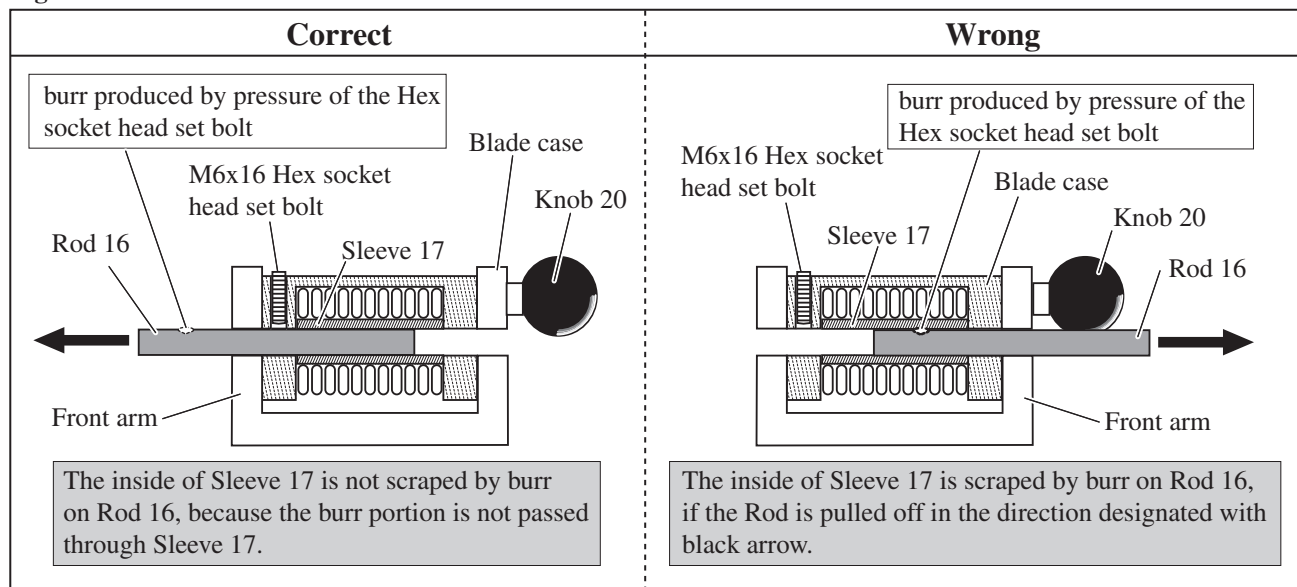
**Fig. 10**



**Fig. 11**



**Fig. 12**



► **Repair**

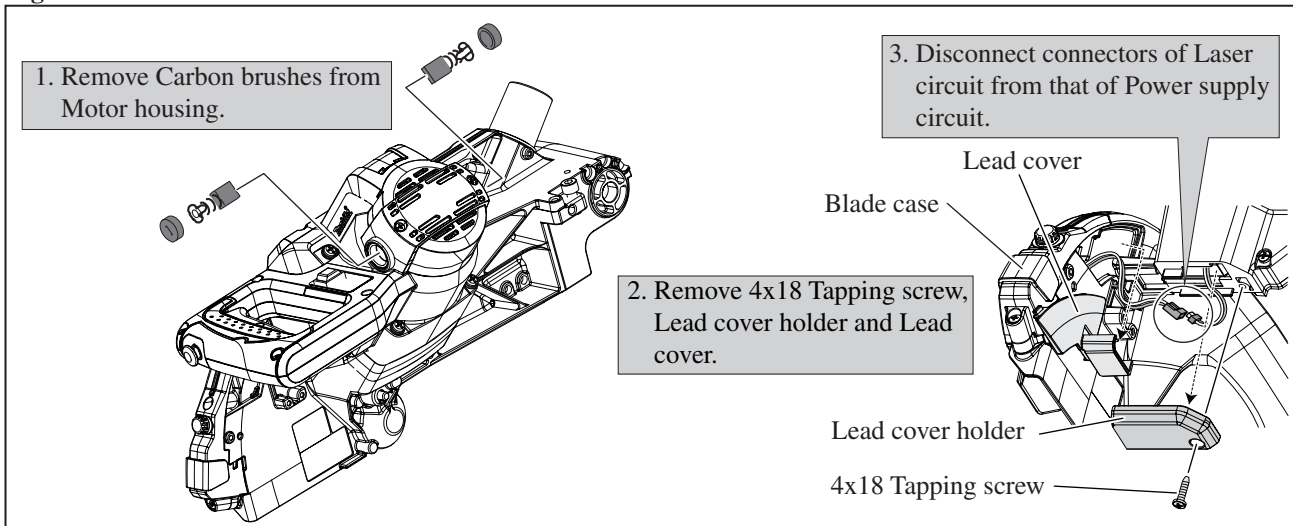
**[3] DISASSEMBLY/ASSEMBLY**

**[3]-1. Blade case, Motor section (cont.)**

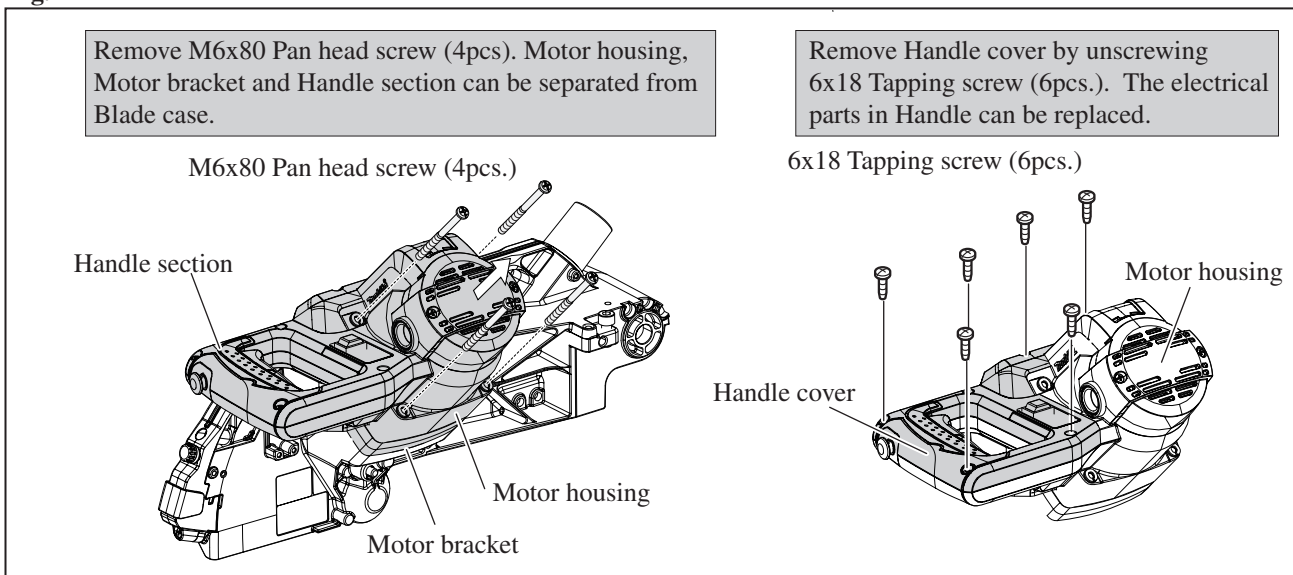
**DISASSEMBLING**

(3) Motor section can be disassembled from Blade case as illustrated in **Figs. 13 and 14.**

**Fig. 13**



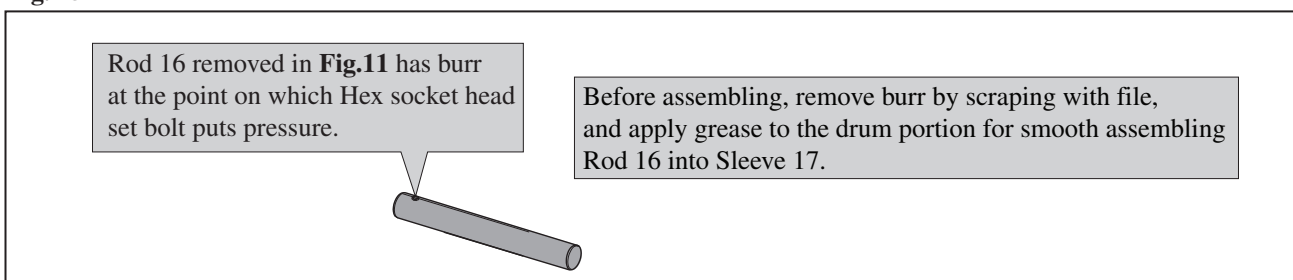
**Fig. 14**



**ASSEMBLING**

(1) Make the drum portion of Rod 16 smooth by filing and applying grease.

**Fig. 15**





► **Repair**

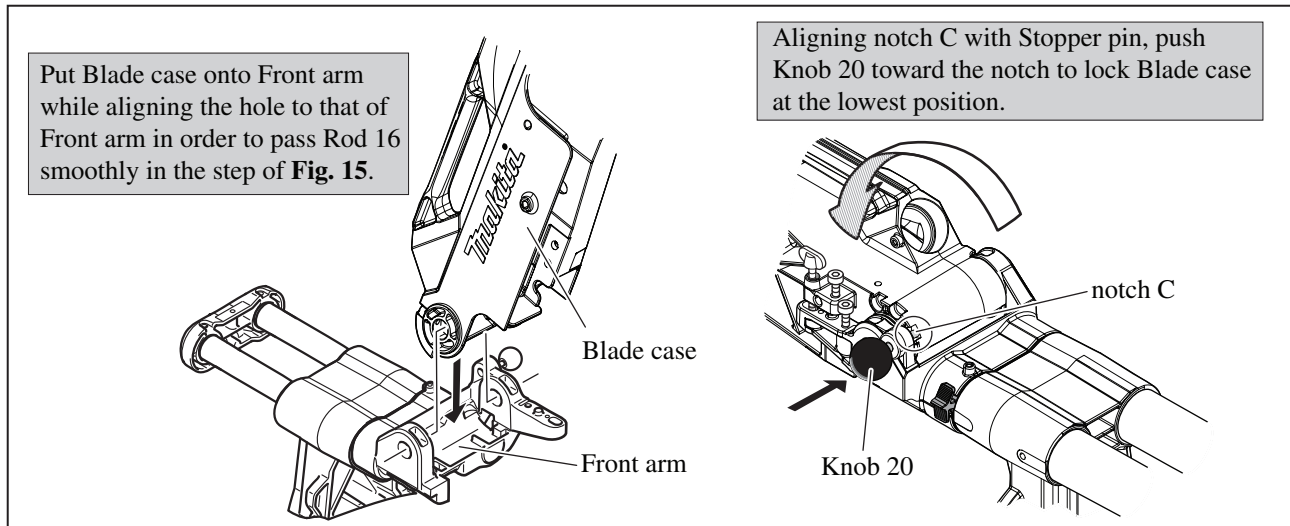
**[3] DISASSEMBLY/ASSEMBLY**

**[3]-1. Blade case, Motor section (cont.)**

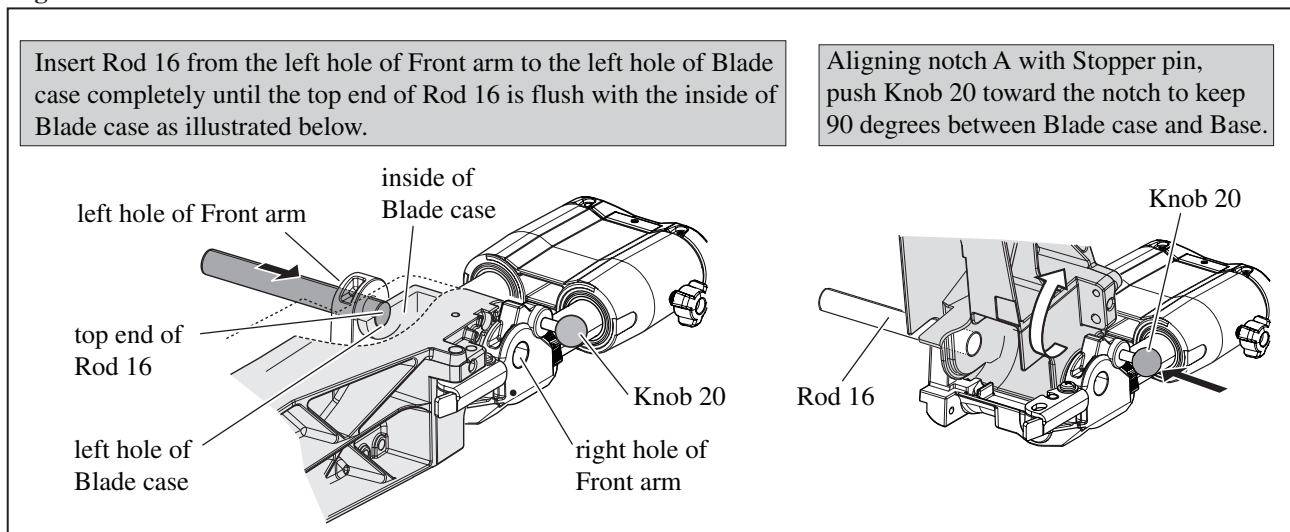
**ASSEMBLING**

(2) Assemble Rod 16 which functions as an axis for Blade case in the order of **Figs. 16 17 and 18.**

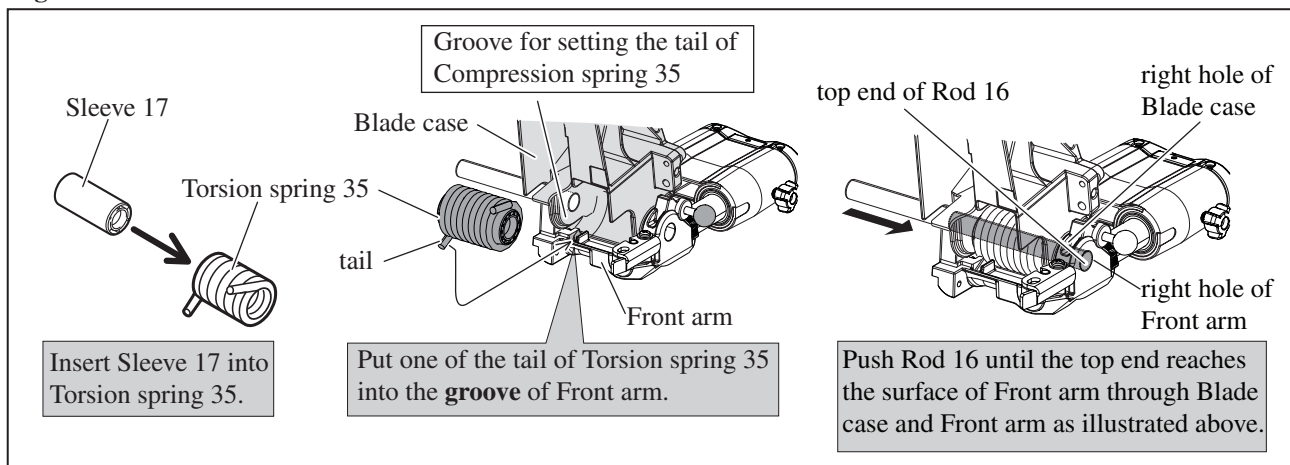
**Fig. 16**



**Fig. 17**



**Fig. 18**



(3) Tighten Torsion spring 35 with M6x20 Hex socket head bolt until the Hex socket head bolt is seated on Blade case. And tighten Rod 16 with M6x16 Hex socket head set bolt. Refer to **right** illustration in **Fig. 10.**

► **Repair**

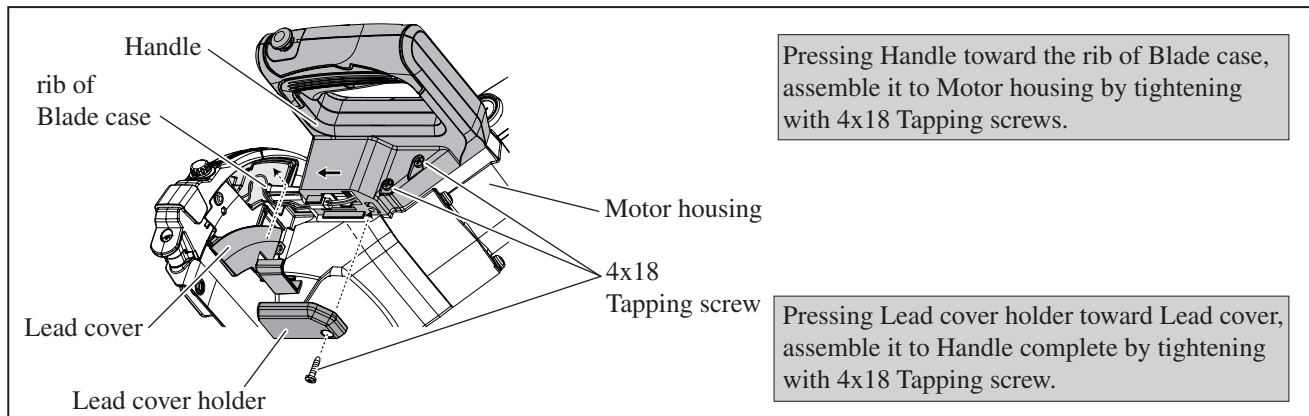
**[3] DISASSEMBLY/ASSEMBLY**

**[3]-1. Blade case, Motor section (cont.)**

ASSEMBLING

(4) When assembling Motor section to Blade case, do as illustrated in **Fig. 19**.

**Fig. 19**

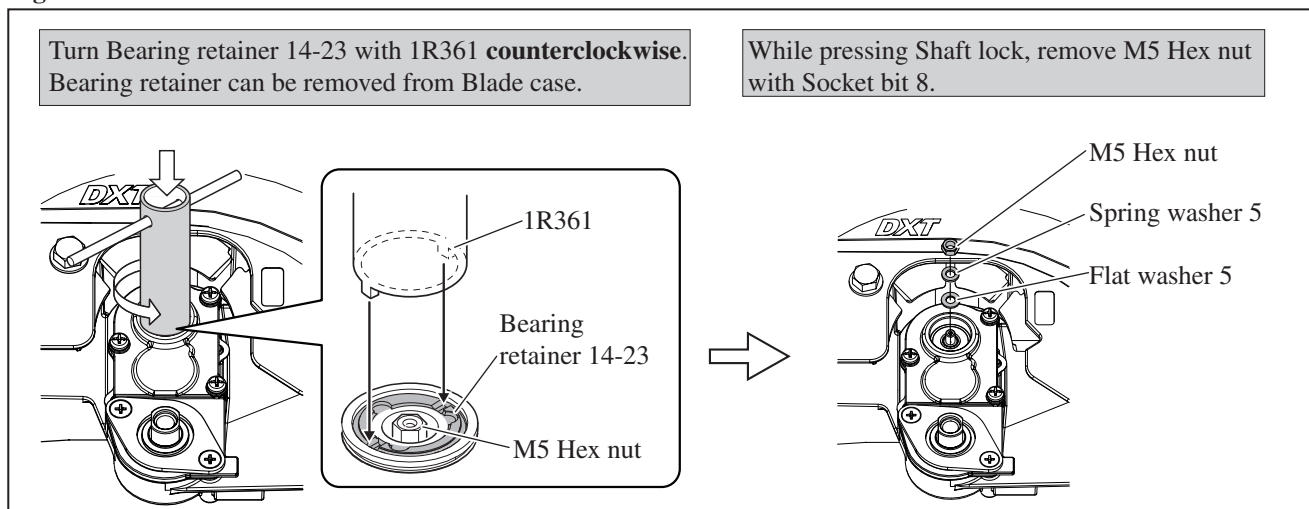


**[3]-2. Gear section (Spiral bevel gear 32, Helical gear 14, Helical gear 27, Helical gear 28)**

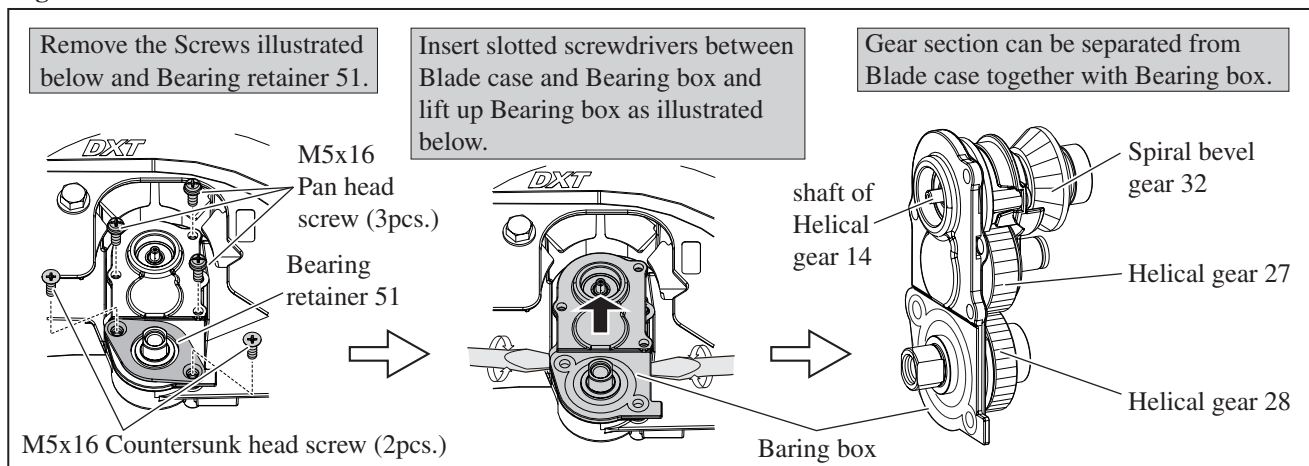
DISASSEMBLING

- (1) Lock Blade case at starting position as illustrated in **Fig. 8**. And remove Link plate as illustrated in **Fig. 9**.
- (2) Remove Motor housing and Handle section as illustrated in **Figs. 13 and 14**. However, no need to remove Handle cover.
- (3) Tilt Blade case in the direction of Motor housing at 45 degrees to prevent Gear portion from falling off. And then, separate Gear section from Blade case as illustrated in **Figs. 20 and 21**.

**Fig. 20**



**Fig. 21**



► **Repair**

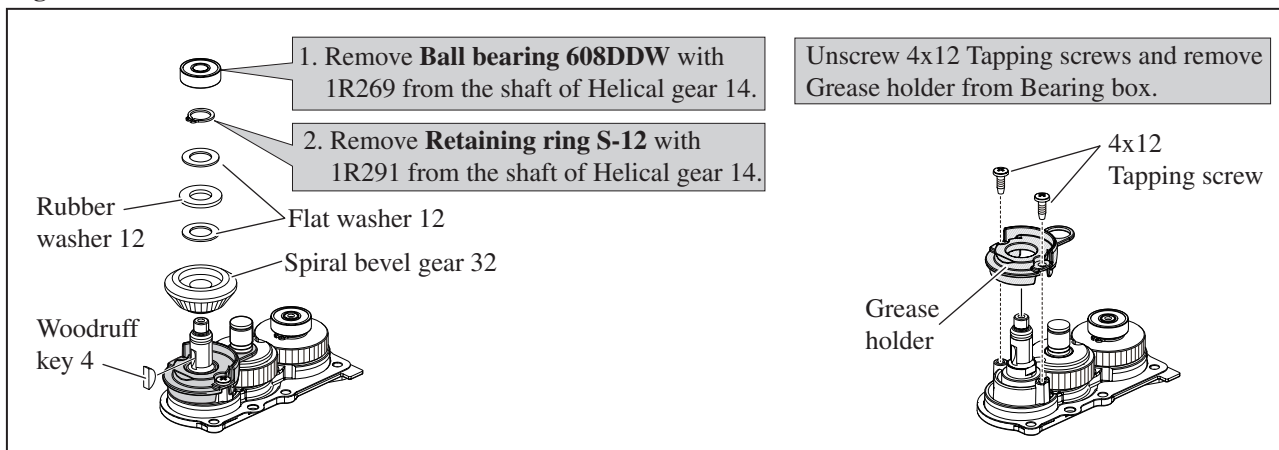
**[3] DISASSEMBLY/ASSEMBLY**

**[3]-2. Gear section (Spiral bevel gear 32, Helical gear 14, Helical gear 27, Helical gear 28)  
(cont.)**

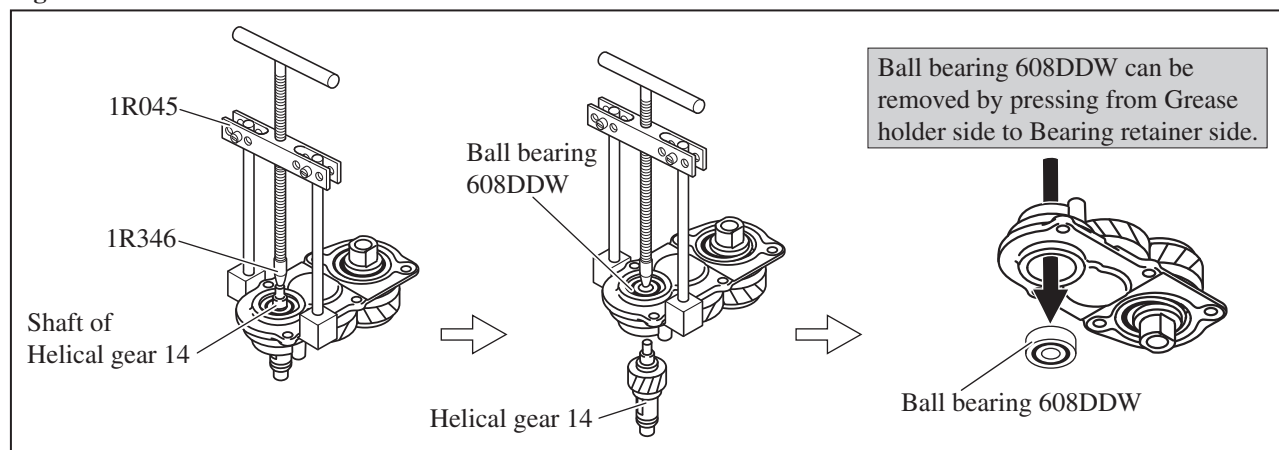
**DISASSEMBLING**

(4) Spiral bevel gear 32 and Helical gear 14 can be disassembled as illustrated in **Figs. 22 and 23**.

**Fig. 22**

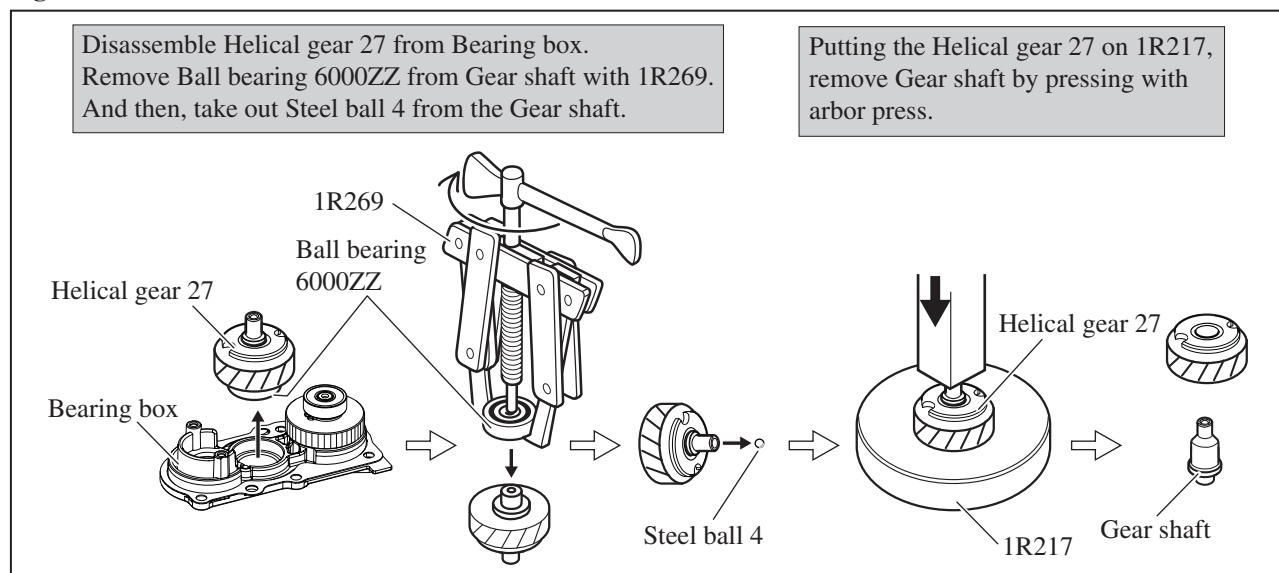


**Fig. 23**



(5) Helical gear 27 and Gear shaft can be disassembled as illustrated in **Fig. 24**.

**Fig. 24**



► **Repair**

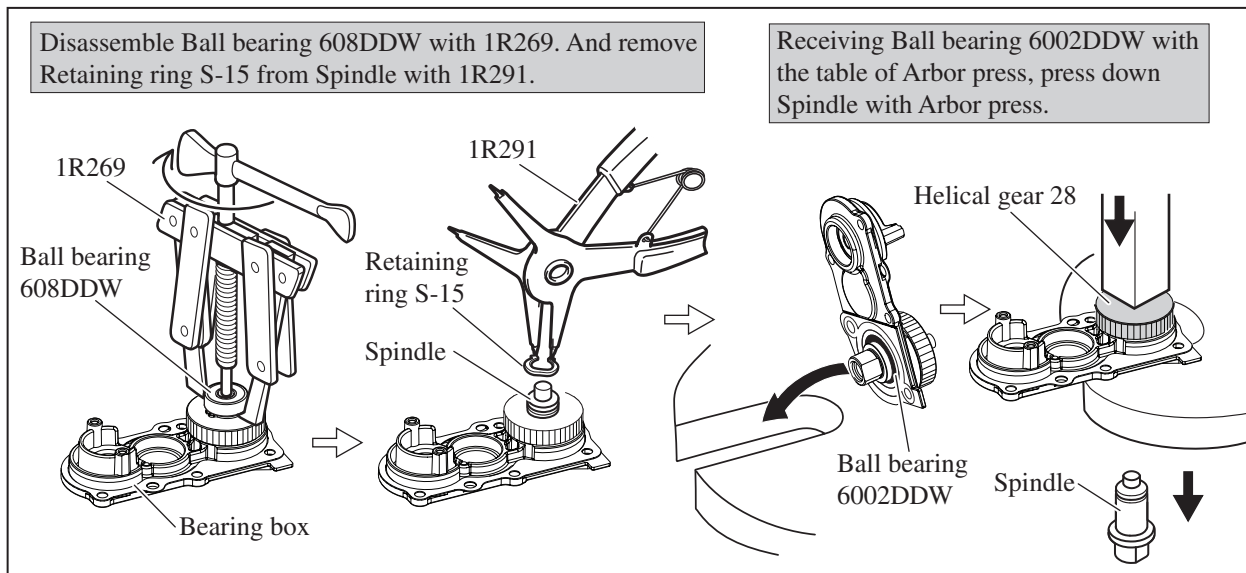
**[3] DISASSEMBLY/ASSEMBLY**

**[3]-2. Gear section (Spiral bevel gear 32, Helical gear 14, Helical gear 27, Helical gear 28)  
(cont.)**

**DISASSEMBLING**

(6) Helical gear 28 and Spindle can be disassembled as illustrated in **Figs. 25**.

**Fig. 25**

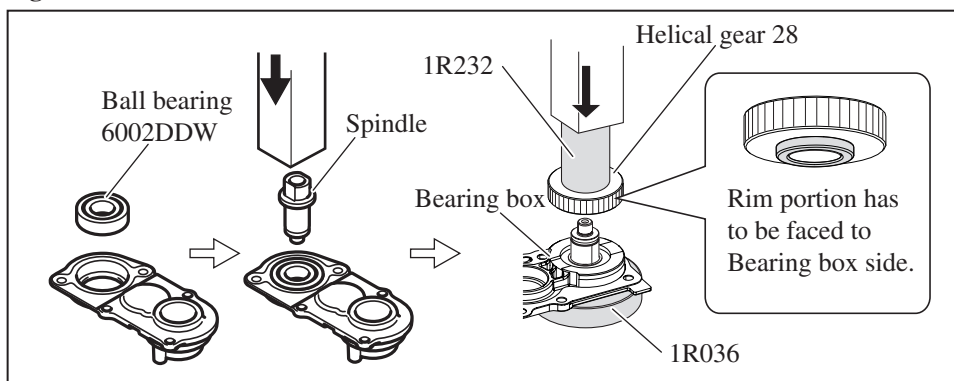


**ASSEMBLING**

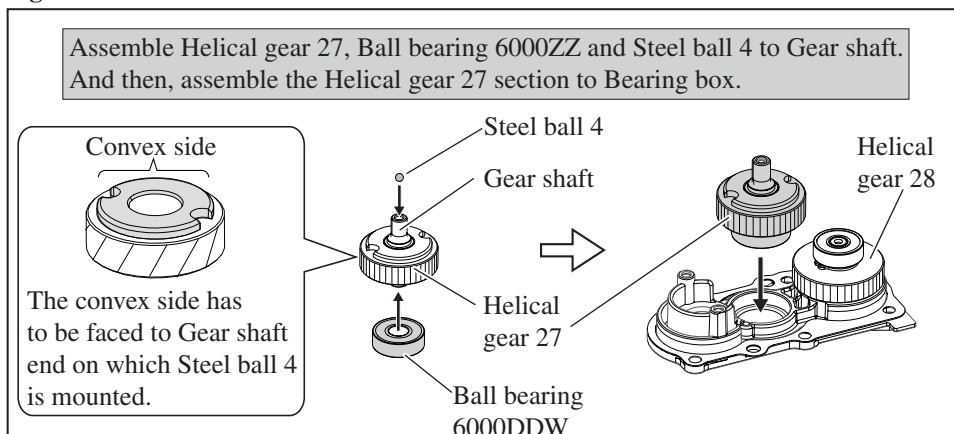
(1) Assemble Helical gear 28 section to Bearing box as illustrated in **Fig. 26**. And then, assemble Retaining ring S-15 and Ball bearing 608DDW to Spindle. Refer to **Fig. 25**.

(2) Assemble Helical gear 27 section to Bearing box as illustrated in **Fig. 27**.

**Fig. 26**



**Fig. 27**



► **Repair**

**[3] DISASSEMBLY/ASSEMBLY**

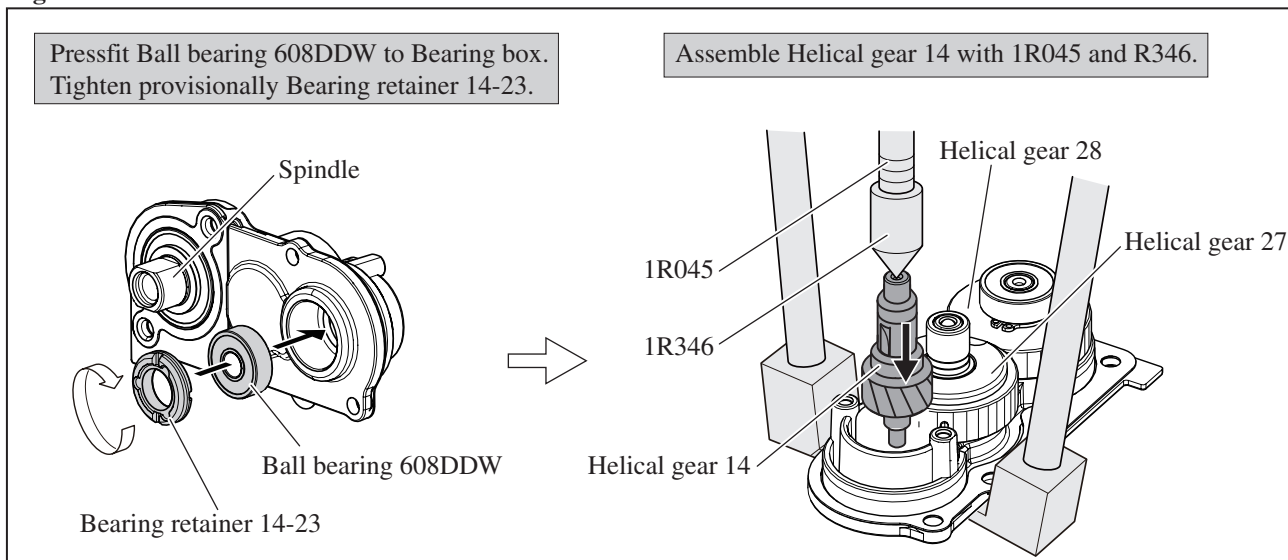
**[3]-2. Gear section (Spiral bevel gear 32, Helical gear 14, Helical gear 27, Helical gear 28)  
(cont.)**

**ASSEMBLING**

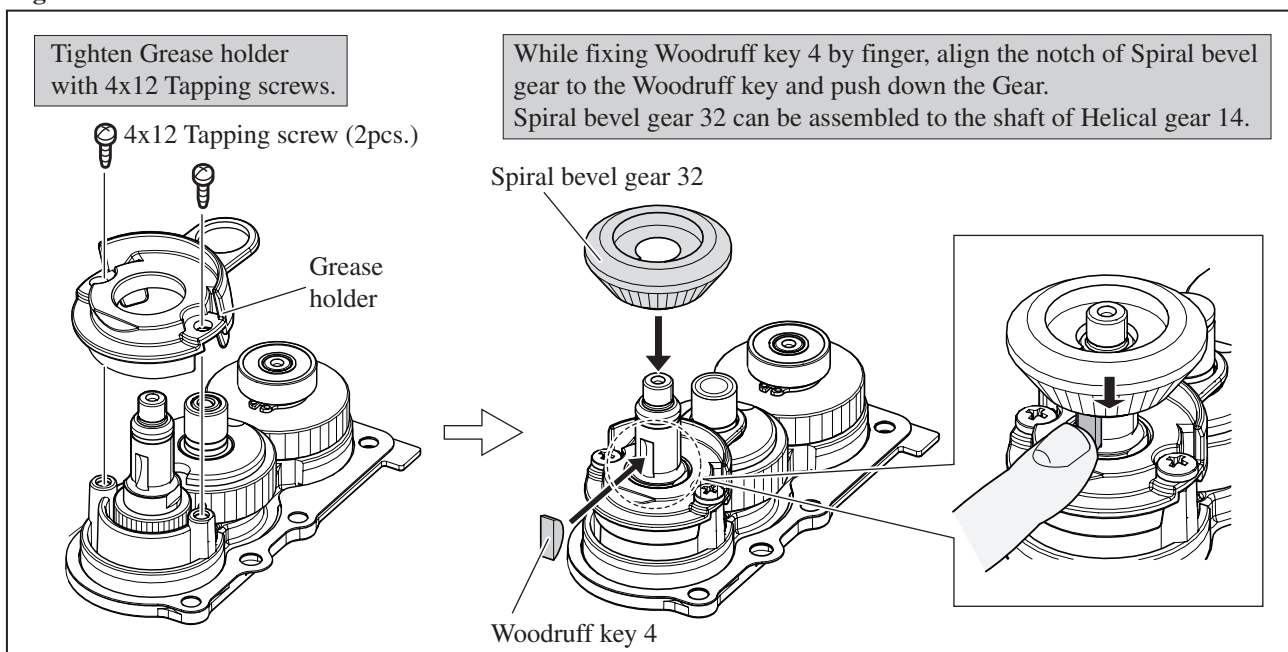
(3) Assemble Helical gear 14 to Bearing box as illustrated in **Fig. 28**.

(4) After mounting Grease holder, set Spiral bevel gear 32 to the shaft of Helical gear 14 as illustrated in **Fig. 29**.

**Fig. 28**



**Fig. 29**



## ► Repair

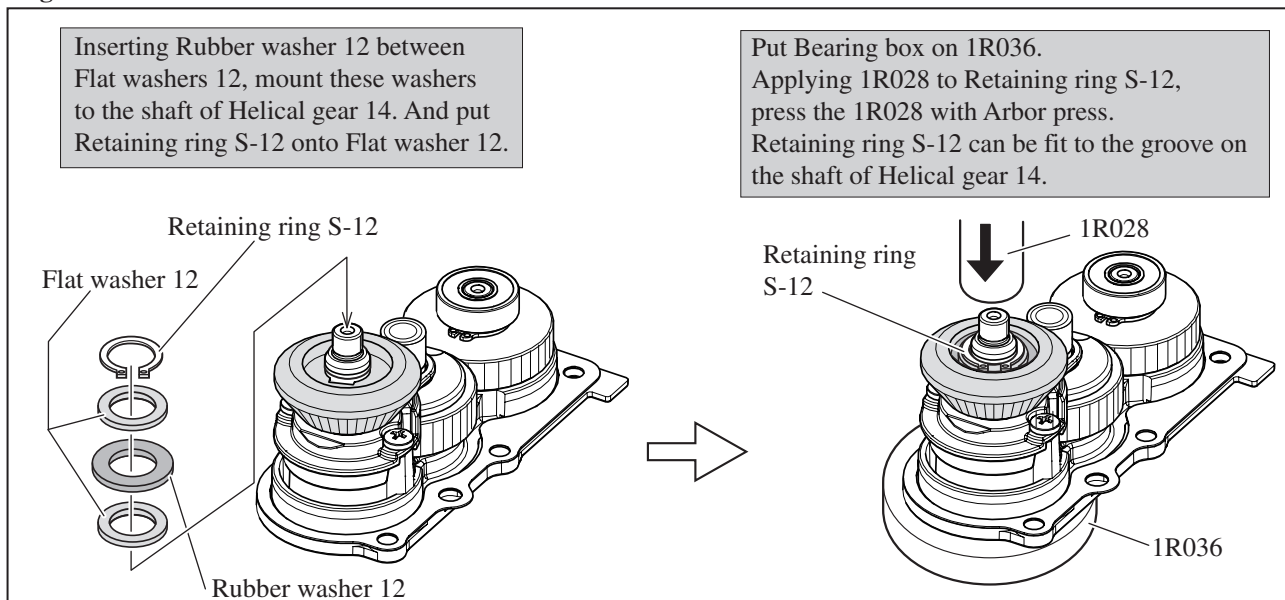
### [3] DISASSEMBLY/ASSEMBLY

#### [3]-2. Gear section (Spiral bevel gear 32, Helical gear 14, Helical gear 27, Helical gear 28)

##### ASSEMBLING

(5) Secure Spiral bevel gear 32 with Retaining ring S-12 as illustrated in **Fig. 30**.

**Fig. 30**



(6) Mount the assembled Gear section to Blade case by fastening with M5x16 Pan head screw (3pcs.).

And fasten Bearing retainer 51 with M5x16 Countersunk head screw (2pcs.). Refer to **Fig. 21**.

(7) Mount Flat washer 5 and Spring washer 5 to the shaft of Helical gear 14. And tighten M5 Hex nut with Socket wrench 8 while pressing Shaft lock. Refer to **the right illustration in Fig. 20**.

(8) Referring to **Fig. 20**, firmly tighten Bearing retainer 14-23 which has been provisionally tightened in the step in **Fig. 28**. Use 1R361 for tightening the Bearing retainer.

(9) Mount Motor housing to Blade case. Refer to **the left illustration in Fig. 14 and the left illustration in Fig. 13**.

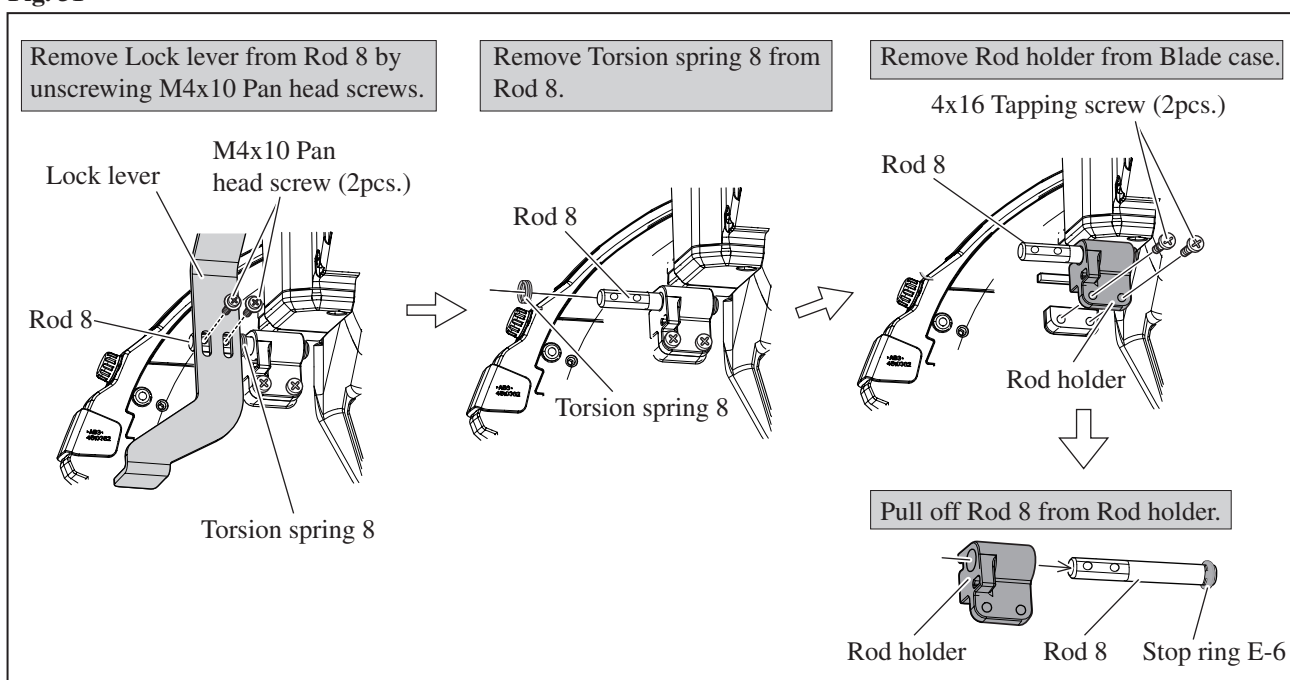
(10) Assemble Link plate complete. Refer to **Fig. 9**.

#### [3]-3. Safety lock mechanism

##### DISASSEMBLING

Disassemble as illustrated in **Fig. 31**.

**Fig. 31**



► **Repair**

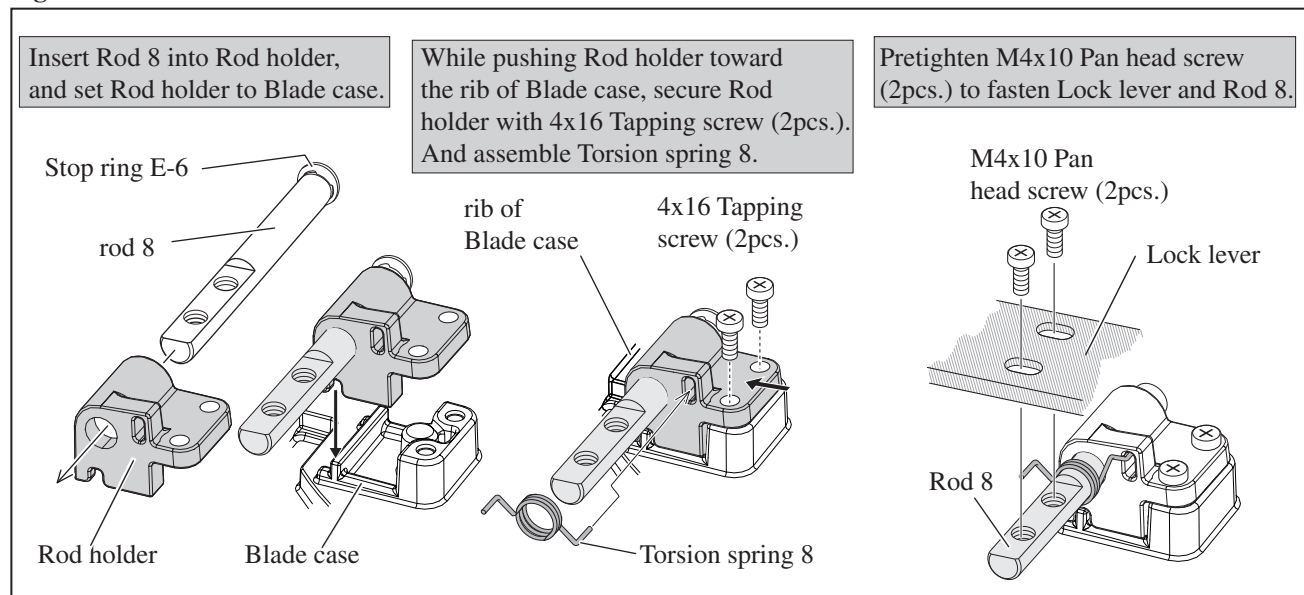
**[3] DISASSEMBLY/ASSEMBLY**

**[3]-3. Safety lock mechanism**

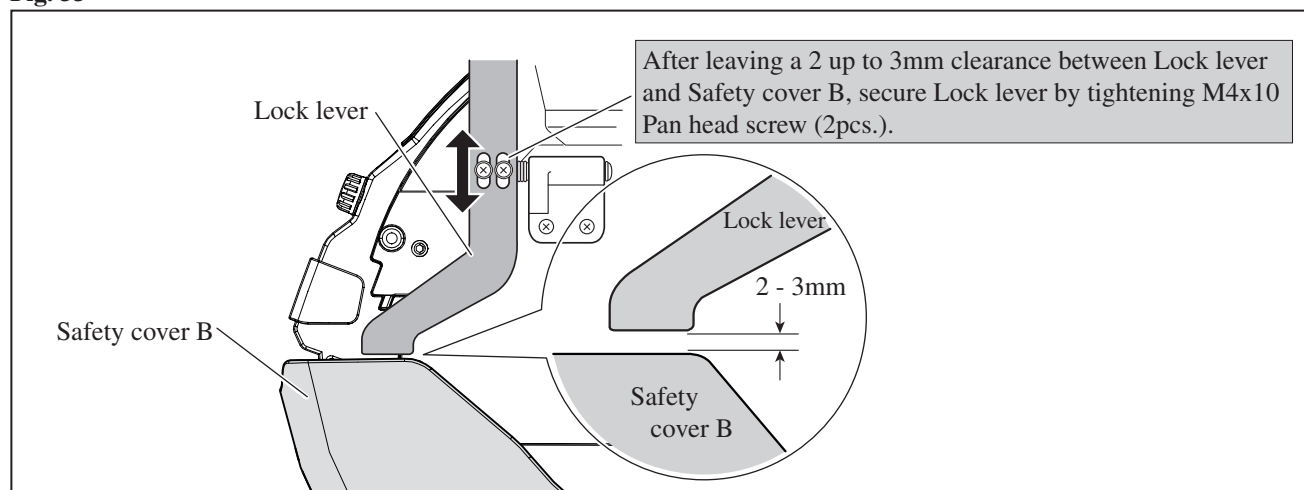
**ASSEMBLING**

- (1) Assemble Safety lock mechanism as illustrated in **Fig. 32**.
- (2) Adjust the position of Lock lever as illustrated in **Fig. 33**.

**Fig. 32**



**Fig. 33**



► **Repair**

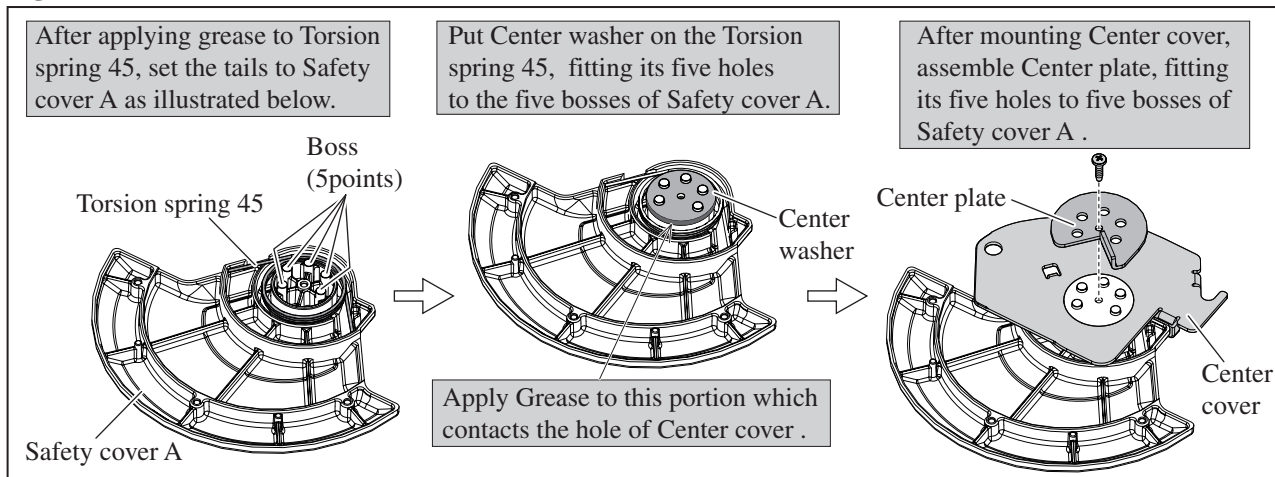
**[3] DISASSEMBLY/ASSEMBLY**

**[3]-4. Safety cover A**

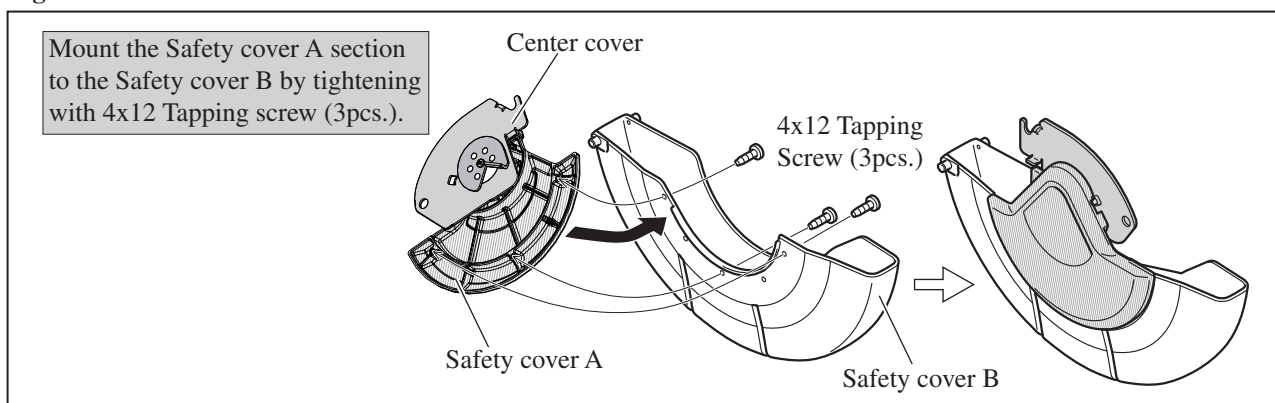
**ASSEMBLING**

- (1) Assemble Safety cover A section as illustrated in **Fig. 34**. And then mount the Safety cover A section to Safety cover B as illustrated in **Fig. 35**.
- (2) Mount the Safety cover section to Blade case complete as illustrated in **Fig. 36**.

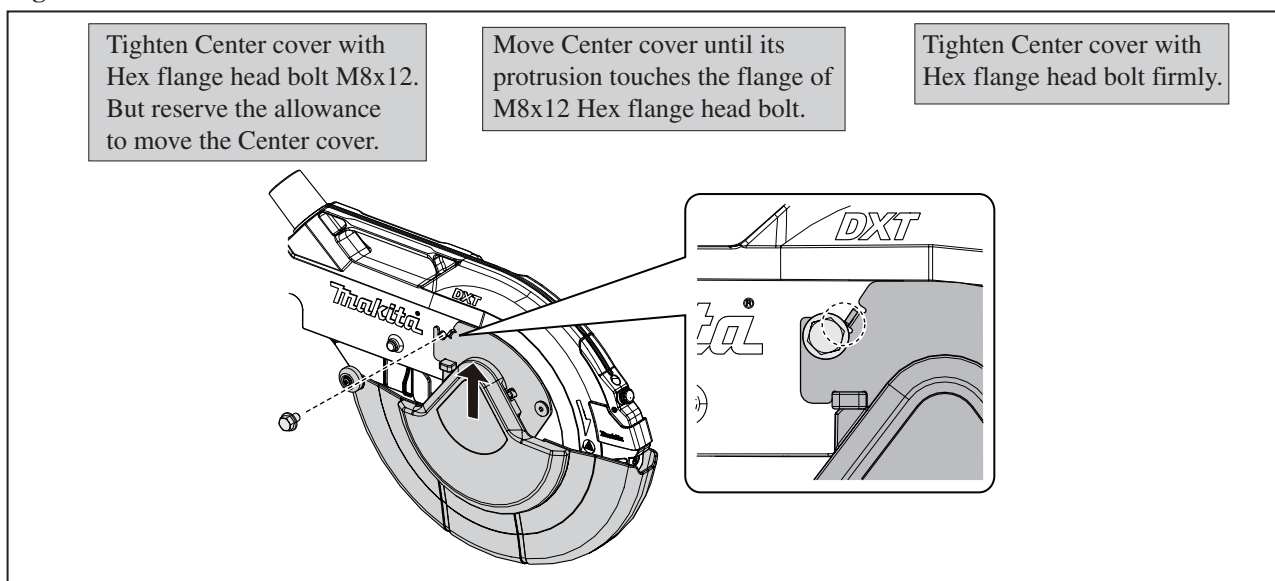
**Fig. 34**



**Fig. 35**



**Fig. 36**





► **Repair**

**[3] DISASSEMBLY/ASSEMBLY**

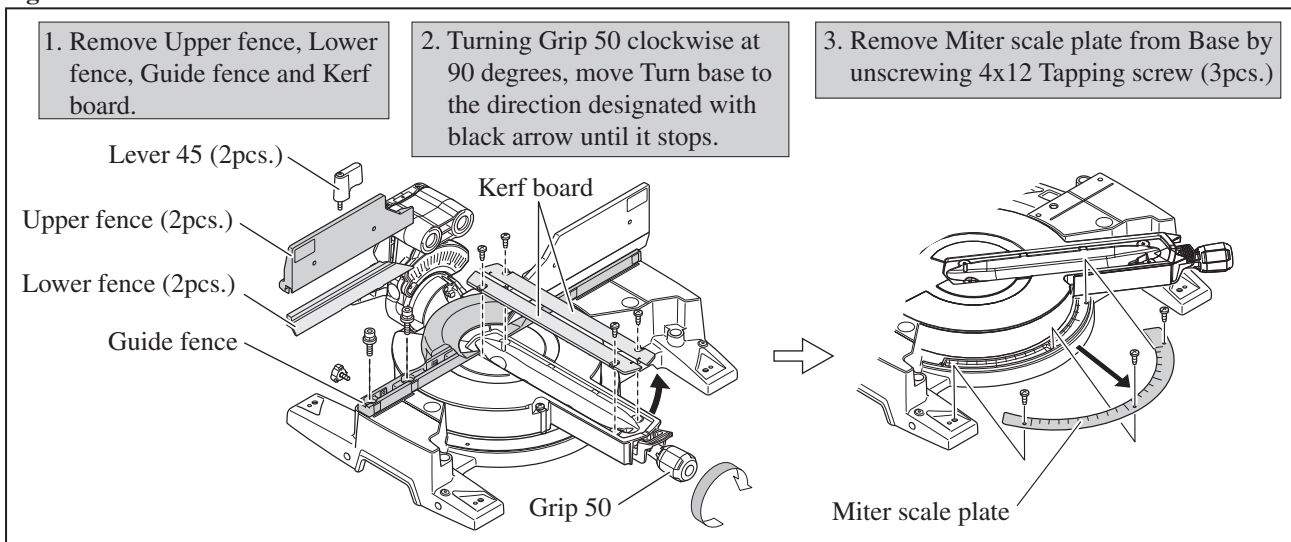
**[3]-5. Turn Base, Base**

**DISASSEMBLING**

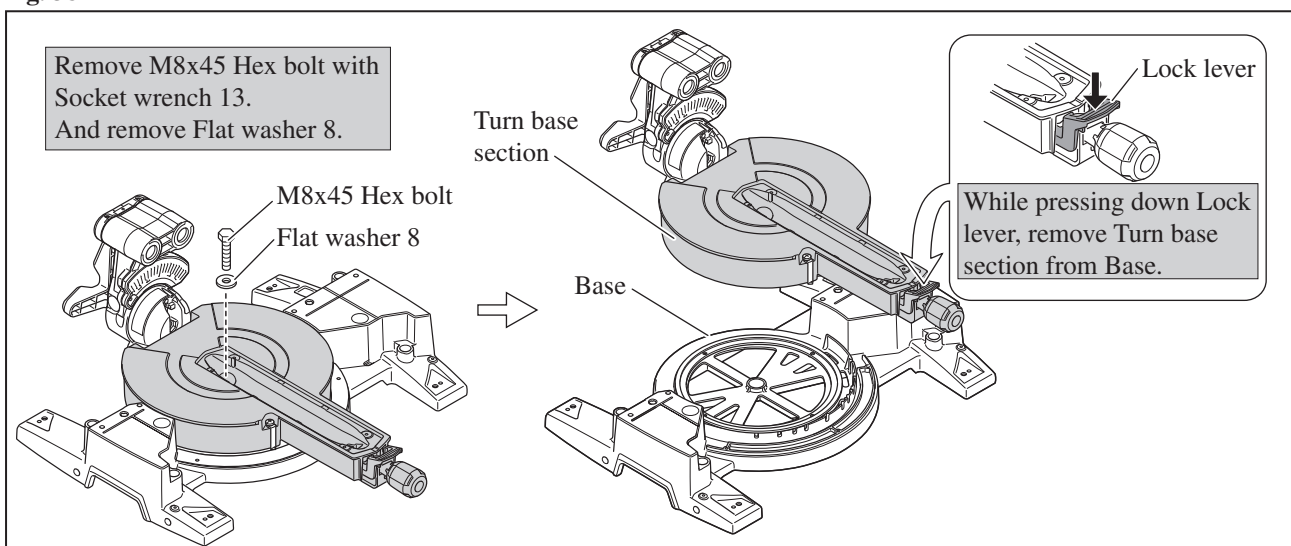
(1) Remove the parts from Turn base and Base as illustrated in **Fig. 37**.

(2) Removing M8x45 Hex bolt, separate Turn base section from Base as illustrated in **Fig. 38**.

**Fig. 37**



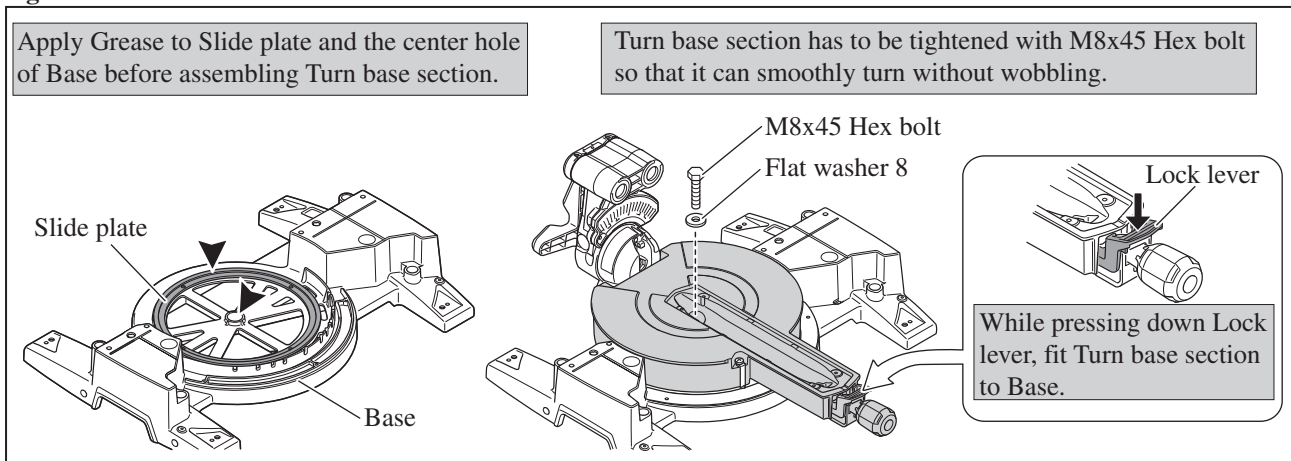
**Fig. 38**



**ASSEMBLING**

Assemble Turn base section as illustrated in **Fig. 39**. And then, take the disassembling step in reverse. Refer to **Fig. 37**.

**Fig. 39**



► **Repair**

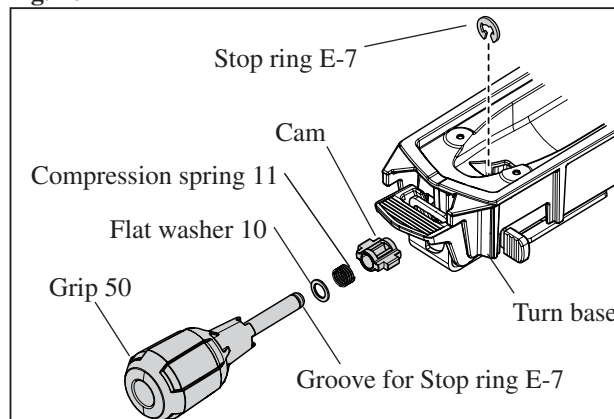
**[3] DISASSEMBLY/ASSEMBLY**

**[3]-6. Positive lock mechanism of Turn base**

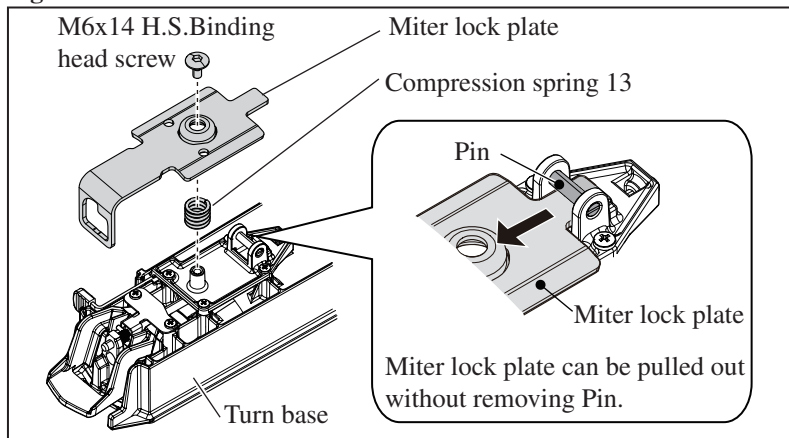
**DISASSEMBLING**

- (1) Remove Stop ring E-7. (**Fig. 40**)  
Grip 50, Compression spring 11, Flat washer 10 and Cam can be removed.
- (2) Remove M6x14 H.S.Binding head screw then remove Miter lock plate in the direction designated with black arrow. (**Fig. 41**)
- (3) Remove CT 4x16 Tapping screw (2pcs.) and Lock lever plate. (**Fig. 42**)
- (4) Push Lock pin 6 in the direction designated with black arrow and pick up Lock lever in the direction designated with gray arrow. (**Fig. 43**)
- (5) Remove Pin 3 from Lock pin 6, then pull out Lock pin 6 in the direction designated with black arrow. (**Fig. 44**)

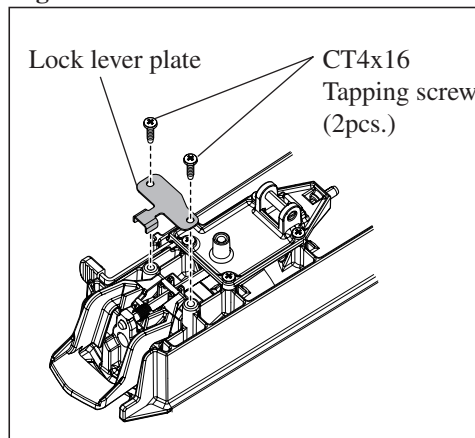
**Fig. 40**



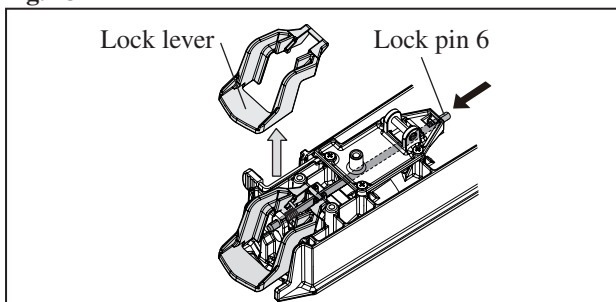
**Fig. 41**



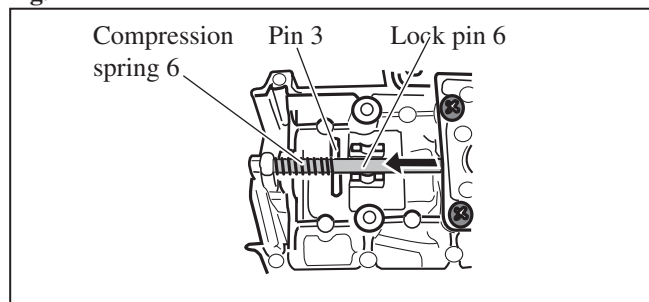
**Fig. 42**



**Fig. 43**



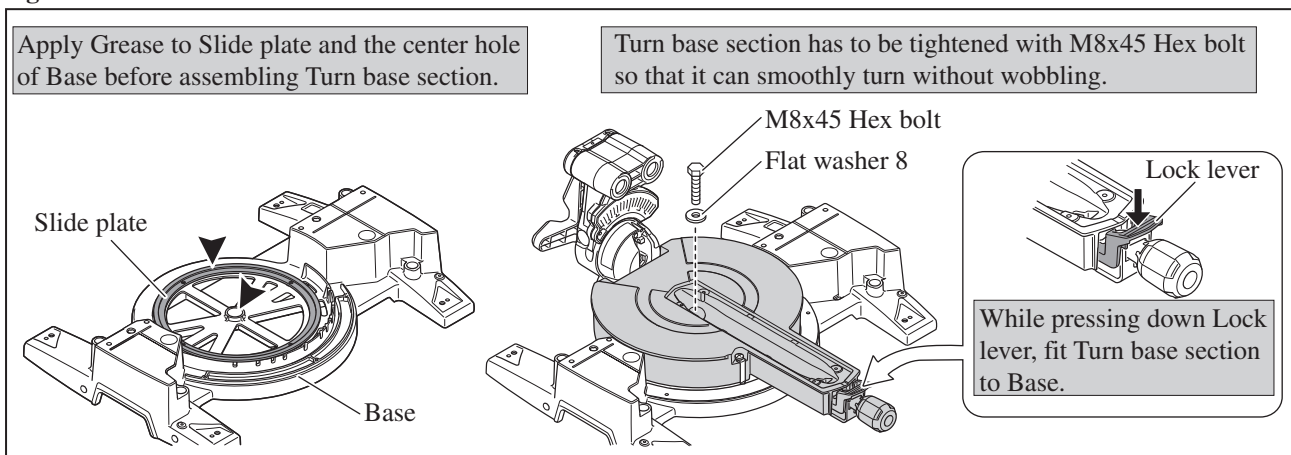
**Fig. 44**



**ASSEMBLING**

Assemble Turn base section as illustrated in **Fig. 45**. And then, take the disassembling step in reverse. Refer to **Fig. 37**.

**Fig. 45**



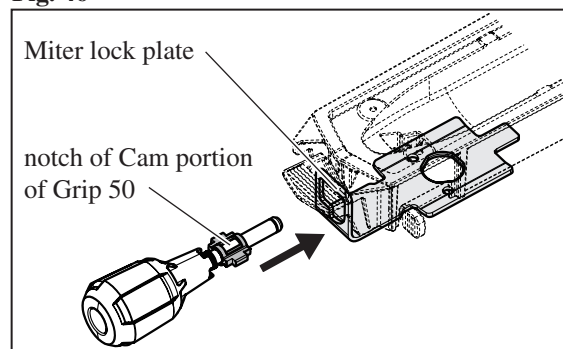
## ► Repair

### [3] DISASSEMBLY/ASSEMBLY

#### [3]-6. Positive lock mechanism of Turn base (cont.)

##### ASSEMBLING

**Note:** Assemble Grip 50 to Miter lock plate as illustrated in **Fig. 46** so that the notch of Cam portion faces the upper side.

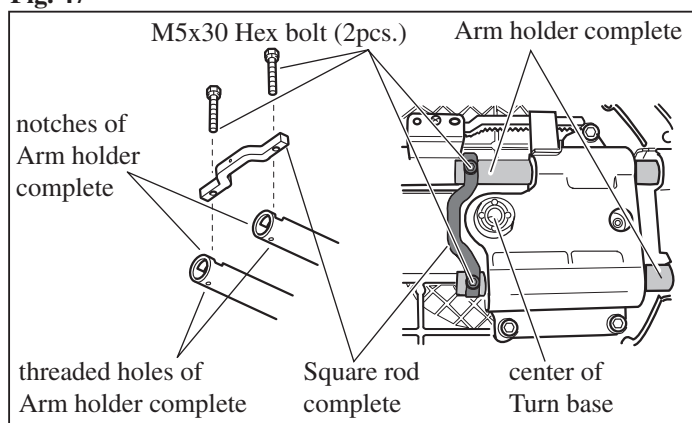


#### [3]-7. Assembling of Square rod complete

Match both ends of Square rod complete with the notches of Arm holder complete on condition that the notches are closest position to the center of Turn base, and tighten M5x30 Hex bolt (2pcs.) as illustrated in **Fig. 47**.

**Note:** Face the concave of Square rod complete to the center of Turn base.

**Fig. 47**



#### [3]-8. Stopper pin

##### DISASSEMBLING

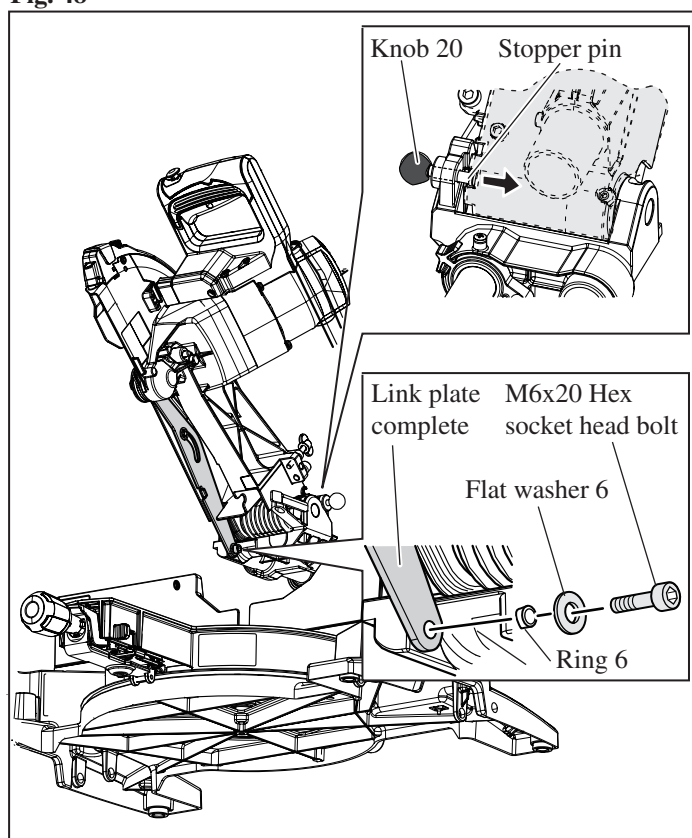
- 1) Push Knob 20 to lock Blade case at highest position in the moving range.  
Then remove M6x20 Hex socket head bolt for securing Link plate. (**Fig. 48**)
  - 2) Lower Blade case slightly to hold Stopper pin, turn Knob 20 counterclockwise a little.
- Note:** Do not remove Knob 20, or Stopper pin will not be pulled.
- 3) Remove Blade case section according to the step shown in clause [3]-1.
  - 4) Remove Knob 20 from Stopper pin, and then pull out Stopper pin in the direction designated with black arrow in **Fig. 48**.

##### ASSEMBLING

Take the disassembling step in reverse.

**Note:** Apply Makita grease SG No.00 to O ring 5 that is fit into Stopper pin. Refer to **Fig. 1**.

**Fig. 48**



► **Repair**

**[3] DISASSEMBLY/ASSEMBLY**

**[3]-9. Front arm section**

**DISASSEMBLING**

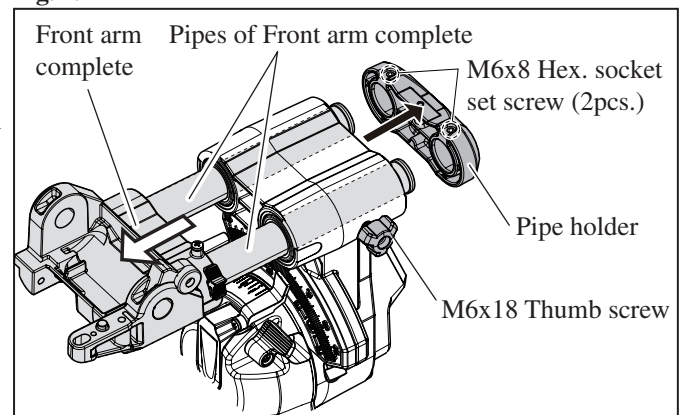
Refer to **Fig. 49**.

- 1) Loosen M6x8 Hex. socket set screw (2pcs.) on Pipe holder and remove Pipe holder.
- 2) Loosen M6x18 Thumb screw and pull out Front arm complete straightly in the direction designated with white arrow to prevent the pipes from being stuck.

**ASSEMBLING**

Take the disassembling step in reverse.

**Fig. 49**

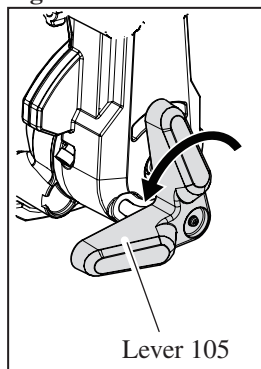


**[3]-10. Arm complete, Arm holder**

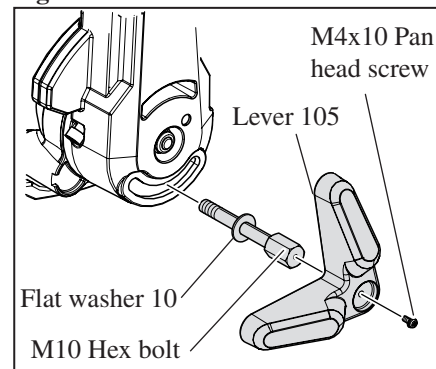
**DISASSEMBLING**

- 1) Loosen Lever 105 by turning counterclockwise. (**Fig. 50**)
- 2) Remove M4x10 Pan head screw and then remove Lever 105. (**Fig. 51**)
- 3) Remove M10 Hex bolt and Flat washer 10. (**Fig. 51**)
- 4) Remove M10-17 Hex lock nut using Box wrench 17.  
Flat washer 10 (2pcs.) and Thrust needle cage 1024 can be removed as illustrated in **Fig. 52**.
- 5) Remove Arm section from Arm holder complete. (**Fig. 53**)
- 6) Remove Retaining ring S-12 from the groove on Arm using 1R291.  
Stopper, Flat washer 12 and Torsion spring 14 can be removed. (**Fig. 54**)  
Remove CT 4x16 Tapping screw (3pcs.) Pointer and Arm cover. (**Fig. 54**)

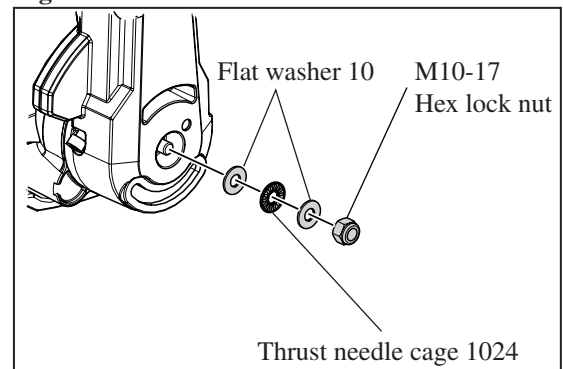
**Fig. 50**



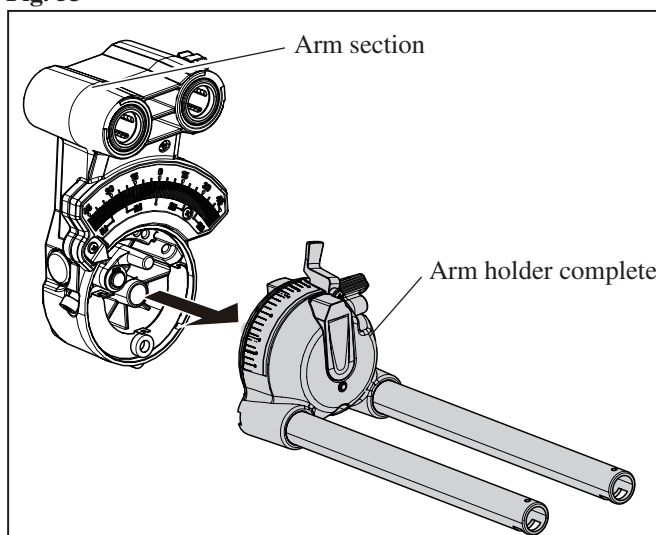
**Fig. 51**



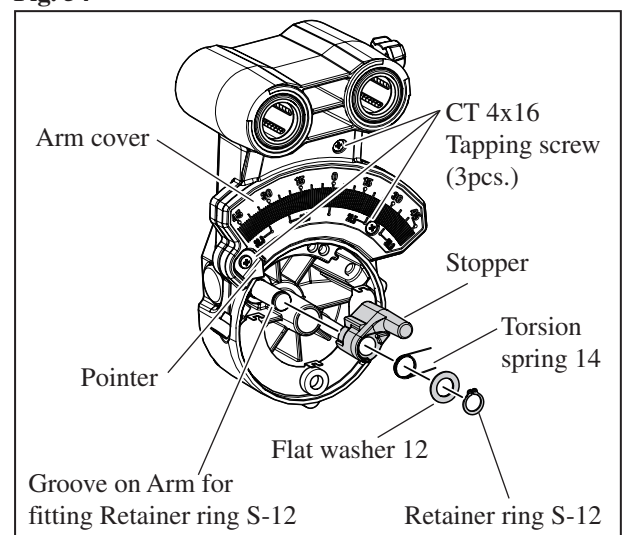
**Fig. 52**



**Fig. 53**



**Fig. 54**



► **Repair**

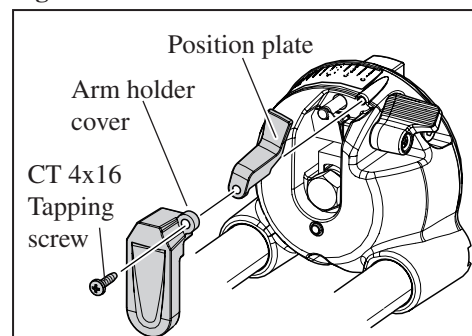
**[3] DISASSEMBLY/ASSEMBLY**

**[3]-10. Arm complete, Arm holder (cont.)**

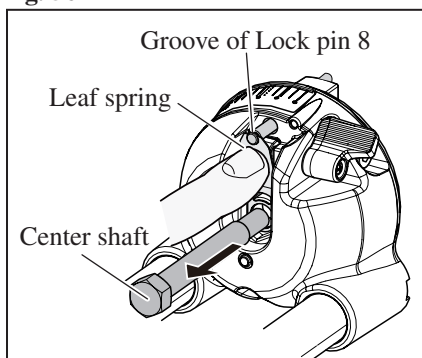
**DISASSEMBLING**

- 7) Remove CT 4x16 Tapping screw.  
Arm holder cover and Position plate can be removed. (Fig. 55)
- 8) Pull out Center shaft while pushing Leaf spring as illustrated in Fig. 56.
- 9) After removing Leaf spring from Lock pin 8, pull out Lock pin 8 and Compression spring 6 in the direction with black arrow. (Fig. 57)
- 10) Attach a thin slotted screwdriver to Stop ring E-4, and strike the head of the screwdriver by hand. (Fig. 58)  
Stop ring E-4, Cam and Lever 22 section can be removed.
- 11) Lever 22 section can be separated by removing M4x10 Pan head screw. (Fig. 59)

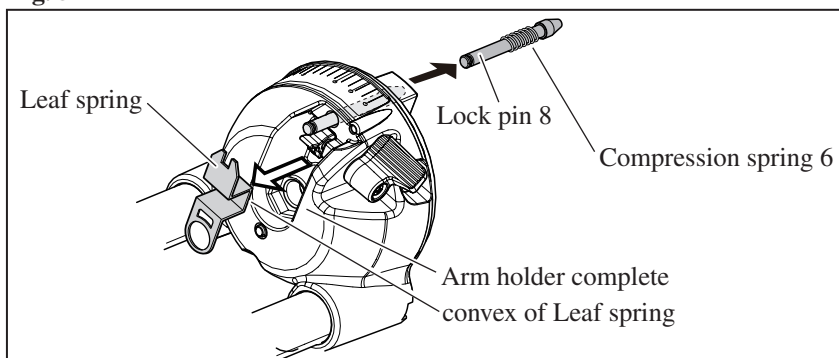
**Fig. 55**



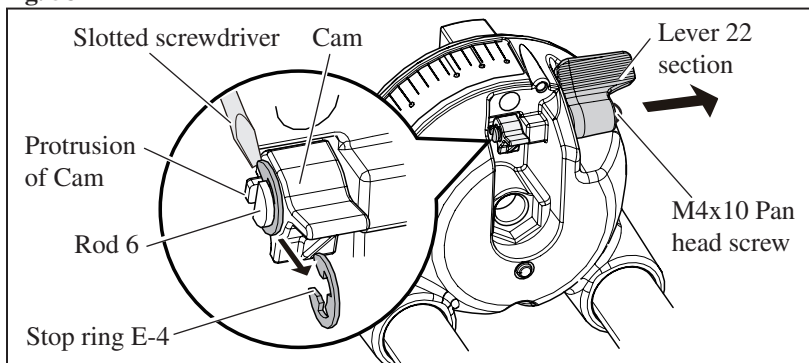
**Fig. 56**



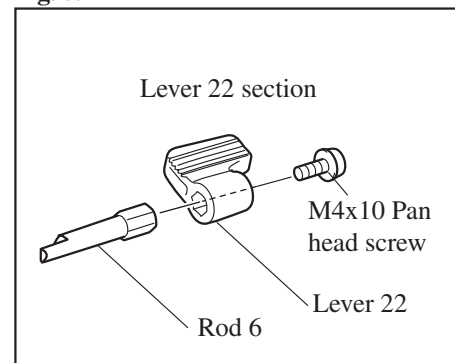
**Fig. 57**



**Fig. 58**



**Fig. 59**

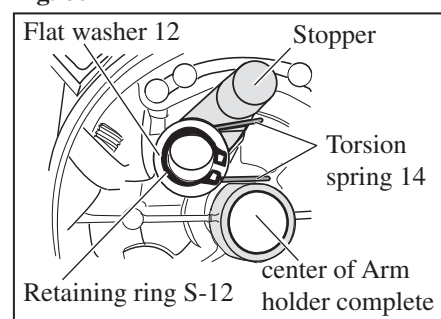


**ASSEMBLING**

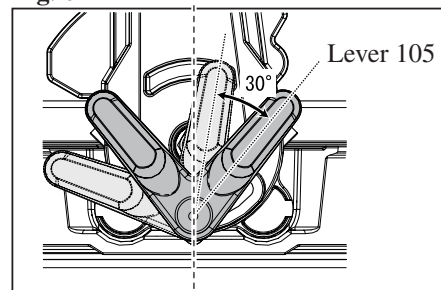
Take the disassembling step in reverse.

- Note:**
- 1) Leaf spring has to be hooked with the groove of Lock pin 8. (Fig. 56)
  - 2) Do not face the convex of Leaf spring to the opposite of Arm holder complete. (Fig. 57)
  - 3) Pay attention to the direction of Rod 6. As illustrated in Figs 58 and 59. Tabs on the ends of Stop ring E-4 have to be fit between the protrusion of Cam and the flat portion of Rod 6. Tab on the center of Stop ring E-4 has to be fit into the groove of Cam.
  - 4) M10-17 Hex lock nut illustrated in Fig. 52 has to be tighten to 3.5 up to 4.0N.m. using 1R254, 1R220, 1R222 and Socket assembly 17-38. When Lever 105 is set in place and Handle is held by hand, Motor section has to be smoothly tilted without wobbling. Therefore, do fine adjustment of M10-17 Hex lock nut.
  - 5) One end of Torsion spring 14 has to be hooked with Stopper. The other of Torsion spring 14 has to be hooked with the center of Arm holder complete as illustrated in Fig. 60.
  - 6) Lever 105 has to be secured at 0 up to 30 degrees tilted counter-clockwise (illustrated in light gray color) from the axial-symmetry position (illustrated in dark gray color) as illustrated in Fig. 61.

**Fig. 60**



**Fig. 61**



► **Repair**

**[3] DISASSEMBLY/ASSEMBLY**

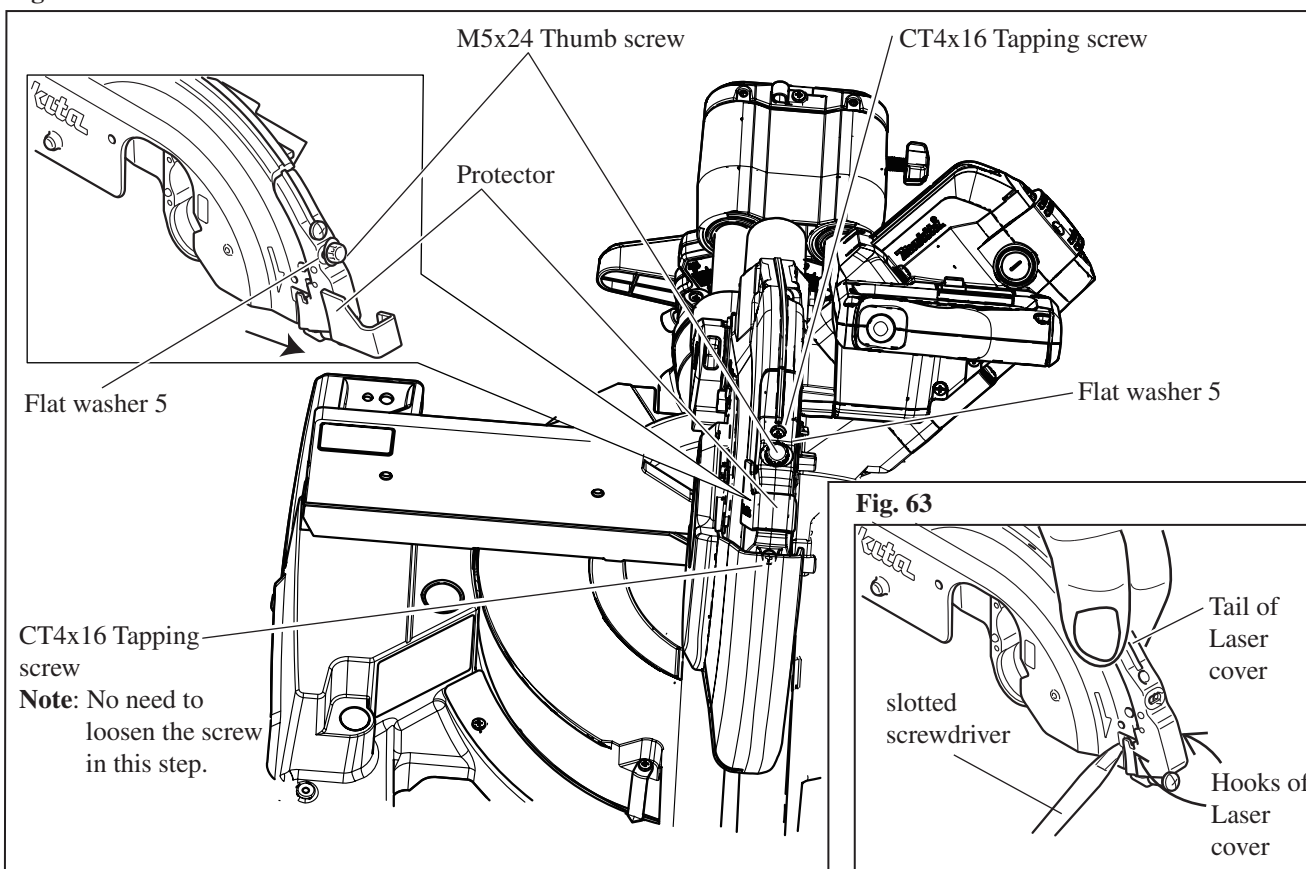
**[3]-12. Laser Mechanism (for LS1016L only)**

**DISASSEMBLING**

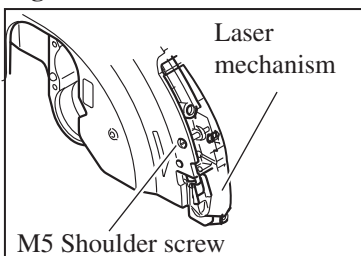
**Note:** Makita-operated or authorized repair shops do maintenance of Laser mechanism.

- 1) As shown in **Fig. 13**, remove 4x18 Tapping screw and Lead cover holder.  
Then disconnect Connectors of Laser circuit from that of Power supply cord, and remove Lead cover.
- 2) Remove Protector, M5x24 Thumb screw and Flat washer 5. (**Fig. 62**)
- 3) Remove one of two CT4x16 Tapping screw on Laser cover. While expanding Laser cover using Slotted screwdriver to remove two hooks of Laser cover from Blade case and pick up the tail of Laser cover as shown in **Fig. 63**.
- 4) Remove M5 Shoulder screw using thin slotted screwdriver. Laser mechanism can be pulled up. (**Fig. 64**)
- 5) Remove Compression spring 6 from Laser mechanism. (**Fig. 65**)
- 6) Remove M3x6 Pan head screw A and separate Torsion spring 9 (A). Remove M3x6 Pan head screw B and separate Torsion spring B. (**Fig. 66**)

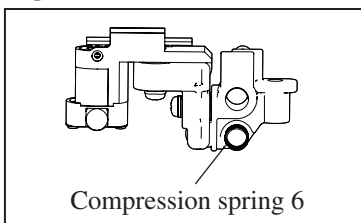
**Fig. 62**



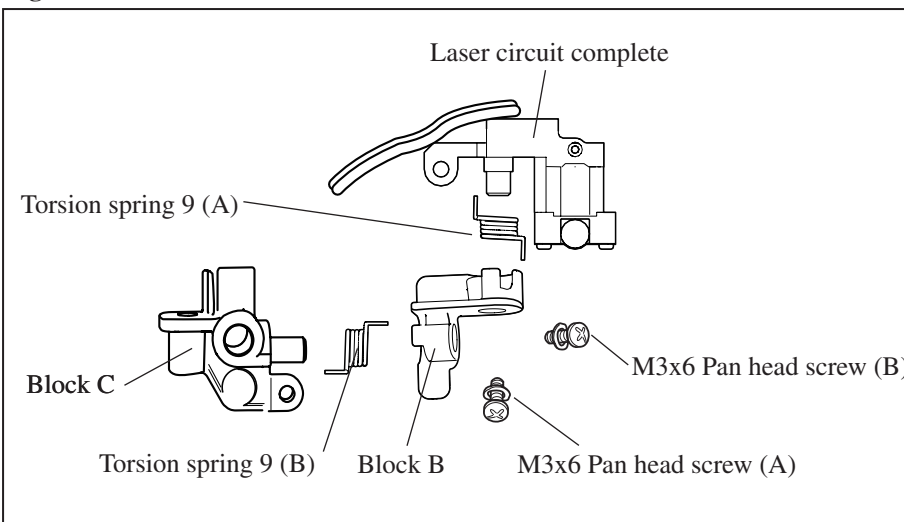
**Fig. 64**



**Fig. 65**



**Fig. 66**



## ► Repair

### [3] DISASSEMBLY/ASSEMBLY

#### [3]-12. Laser Mechanism (for LS1016L only: cont.)

##### ASSEMBLING

Take the disassembling step in reverse.

**Note:** 1) Hook one end of Torsion springs 9(A) to the groove of Laser circuit complete, and hook the other end to the groove of Block B. Meanwhile, hook one end of Torsion springs 9(B) to the groove of Block C, and hook the other end to the groove of Block B as illustrated in **Fig. 66**. Be careful each end of the Torsion springs. After tightening M3x6 Pan head screws (A) and (B), check if both Blocks B and C can be smoothly pivoted due to the reaction force of Torsion springs 9(A) and 9(B).

2) Align the top of M4x6 Hex socket set screw with the surface of Laser circuit complete. Align the top of the other M4x6 Hex socket set screw with the surface of Block C. (**Fig. 67**)

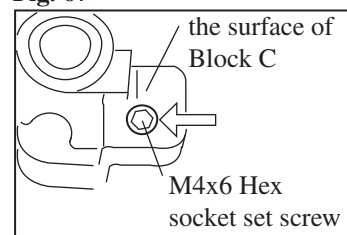
This way makes the fine adjustment of Laser easy.

3) Do not touch the lens of Laser circuit complete, or Laser may be unclear because of dust, dirt and fingerprint.

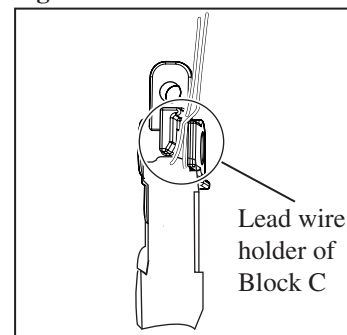
Dust, dirt and fingerprint have to be wiped off using a cotton swab.

4) When assembling Laser mechanism to Blade case complete, put Lead wires into Lead wire holder of Block C. (**Fig. 68**)

**Fig. 67**



**Fig. 68**



### [4] ADJUSTMENT

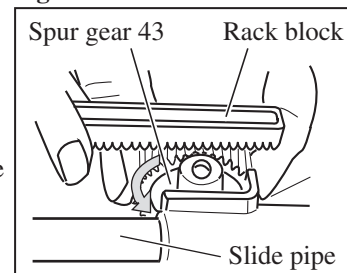
#### [4]-1. Lower-slide lock mechanism

1) Lift up Rack block to disengage with Spur gear 43 and turn Spur gear 43 in the direction designated with gray arrow. (**Fig. 69**) Spur gear 43 can be secured to Slide pipe.

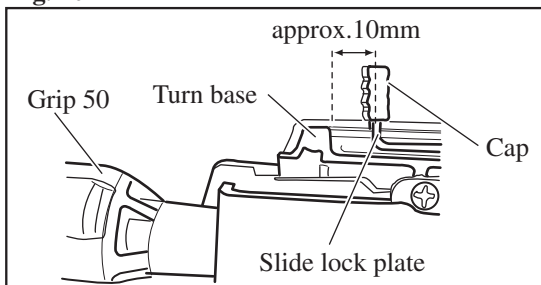
**Note:** Tighten Spur gear 43 to the equivalent torque as M6x18 Thumb screw to Lower fence R.

2) On condition that the clearance between Turn base and Slide lock plate is approximate 10mm as illustrated in **Fig. 70**, secure Leaf spring on Turn base by tightening Bind CT4x12 Tapping screw. (**Fig. 71**)

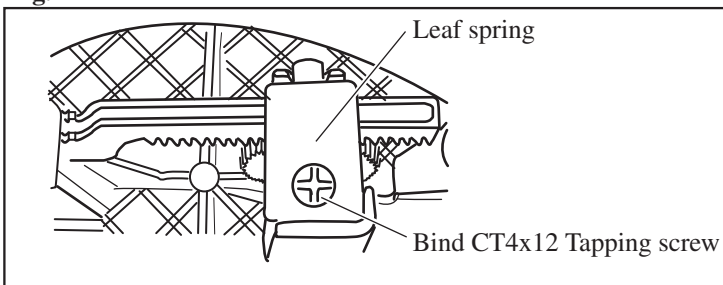
**Fig. 69**



**Fig. 70**



**Fig. 71**



#### [4]-2. Lower fence and Upper fence

1) Put Lower fence R on Guide fence.

Install Upper fence R complete to Lower fence R and then fasten them by turning Lever 45. (**Fig. 72**)

**Note:** Check the following points at this time.

1) Upper fence R complete and Lower fence R can be moved smoothly when M5x6 Hex. socket set screw is loosened.

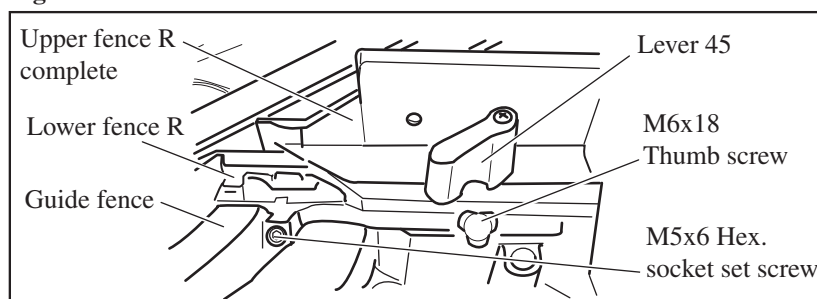
2) Upper fence R complete and Lower fence R can not be moved when M5x6 Hex. socket set screw is tightened.

2) After check shown above, secure Lower fence R to Guide fence by tightening M6x18 Thumb screw.

**Note:** Move the outside end of Lower fence to the farthest possible position from Base at this time, and then fasten Lower fence R to Guide fence.

3) In the same way, set Lower fence L and Upper fence L complete in place.

**Fig. 72**



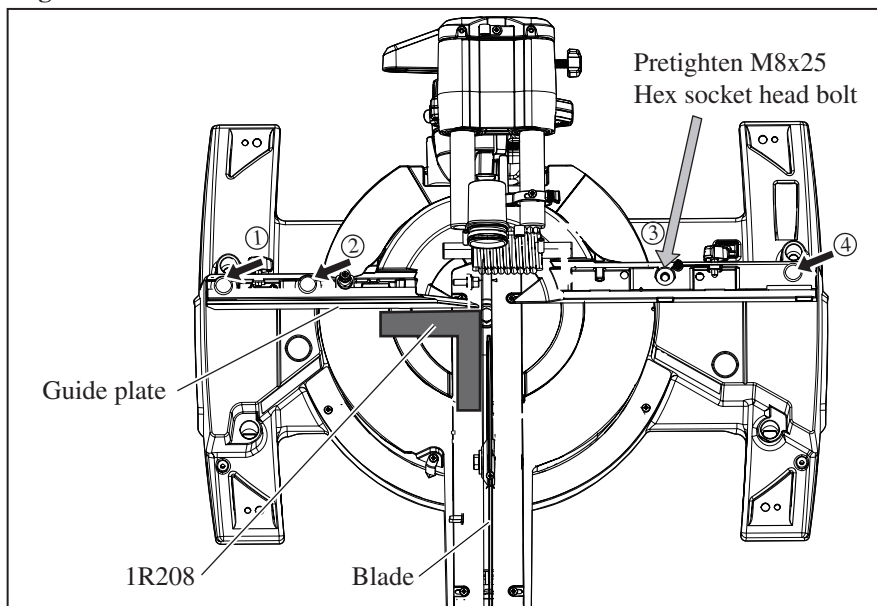
► **Repair**

**[4] ADJUSTMENT**

**[4]-3. Guide fence**

- 1) Pretighten M8x25 Hex socket head bolt (with flat washer and spring washer) at the threaded hole designated with gray arrow. The round shape around the thread hole is smaller than the others (designated with black arrow) for M8x25 Hex socket head bolts.
- 2) Do fine adjustment of the right angle between Blade and Guide fence using 1R208.
- 3) Tighten M8x25 Hex socket head bolt (4pcs.) in order ①②③, and④, without moving any parts. (**Fig. 73**)

**Fig. 73**



**[4]-4. Blade**

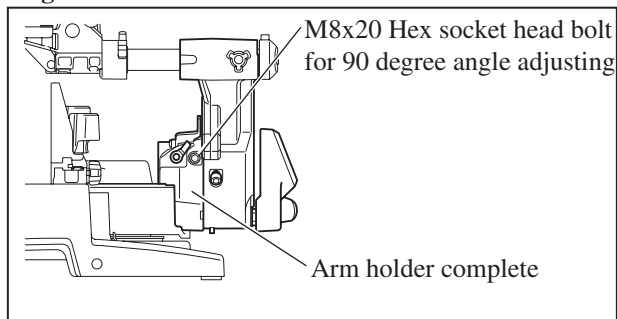
- Use 1R208 and M8x20 Hex socket head bolt on Arm holder complete to adjust 90 degree angle between Blade and Turn base. (**Fig. 74**)
- Use 1R207 and M8x20 Hex socket head bolts on the right side and the left side of Arm complete to adjust 45 degree angle between Blade and Turn base. (**Fig. 75**)

**Note:** When tilting the carriage to the right, tilt the carriage to the left slightly after loosening the lever and press Release button. Tilting the carriage to the left can be done without pushing Release button.

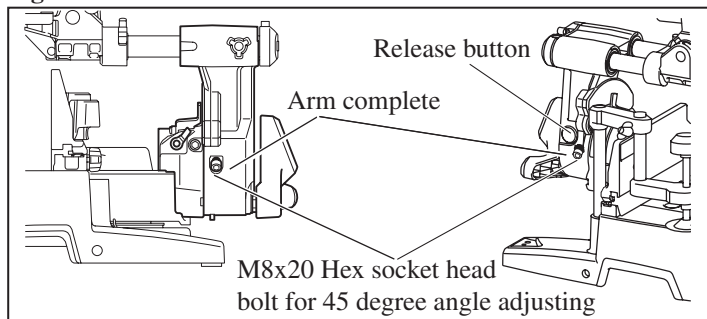
Adjust Maximum cutting depth as follows;

- 1) Lower Stopper lever to position Blade as shown in **Fig. 76**.
- 2) Push the carriage toward Guide fence fully and lower Handle completely. (**Fig. 76**)
- 3) Use the hex end of 782232-8 to turn M8x20 Hex socket head bolt until the periphery of Blade extends slightly below the top surface of Turn base and adjust Blade so that the tip is placed as illustrated in **Fig. 77**.

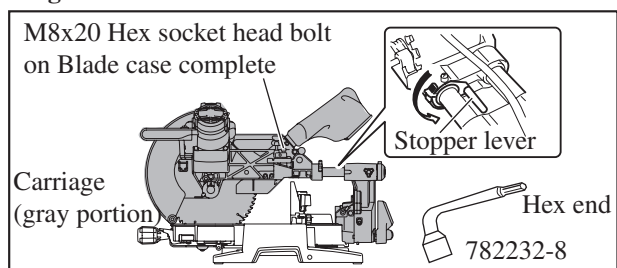
**Fig. 74**



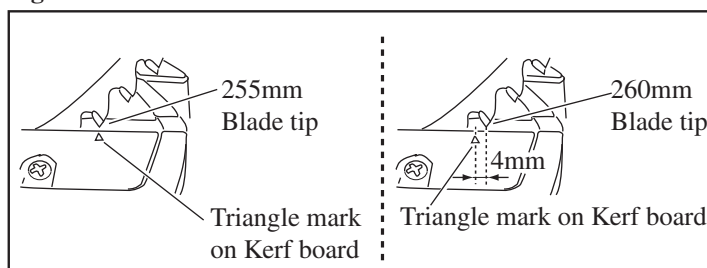
**Fig. 75**



**Fig. 76**



**Fig. 77**





## ► Repair

### [4] ADJUSTMENT

#### [4]-5. Laser (for LS1016L only)

- 1) Remove M10x20 Hex flange head bolt, Outer flange, Inner flange and Blade.  
Then separate Safety cover section from Blade case complete. (Fig. 78)
- 2) Remove Protector. (Fig. 79)
- 3) Place Flat washer 16 on Spindle (Fig. 80) and fasten 1R315 and Flat washer 16 by gently tightening M10x20 Hex flange head bolt as illustrated in Fig. 81.
- 4) Plug the tool to turn on the laser beam.  
**WARNING:** Do not touch Operation switch. (Fig. 82)
- 5) Press the upper position (I) of Switch for Laser. (Fig. 82)
- 6) Slide the position of M5x24 Thumb screw to the center of Laser cover so that a laser beam can be moved as widely as possible to right or left. (Fig. 83)
- 7) Move 1R315 to low side and align the laser beam with 1R315 by adjusting M4x6 Hex socket set screw A as illustrated in Fig. 85.
- 8) Move 1R315 to high side and align the laser beam with 1R315 by adjusting M4x6 Hex socket set screw B as illustrated in Fig. 86.

Fig. 78

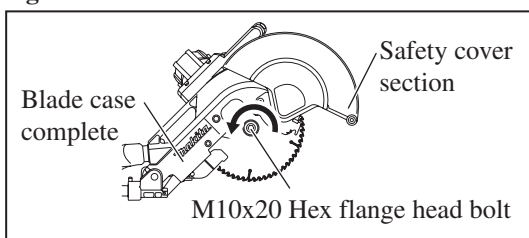


Fig. 79

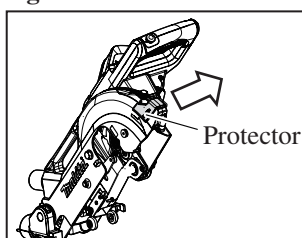


Fig. 80

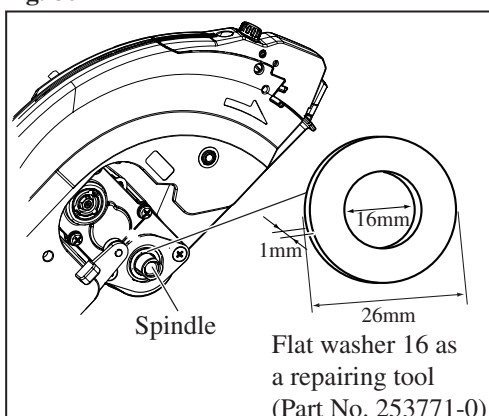


Fig. 81

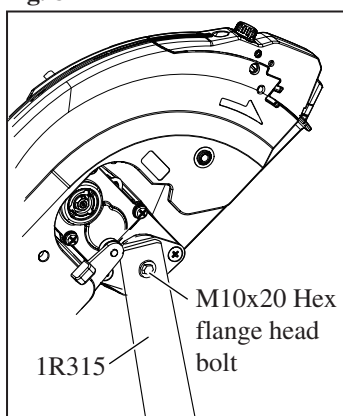


Fig. 82

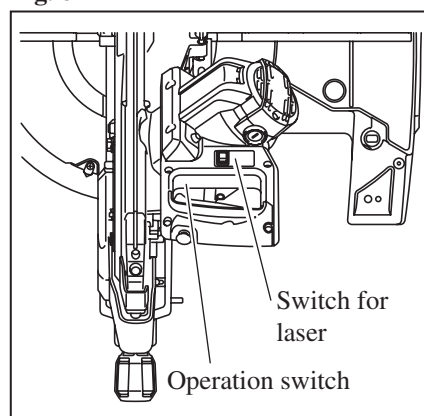


Fig. 83

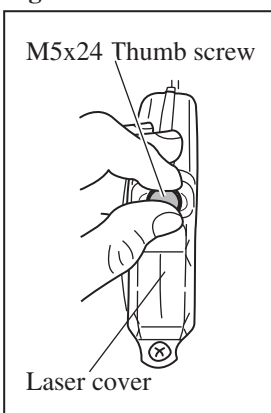


Fig. 85

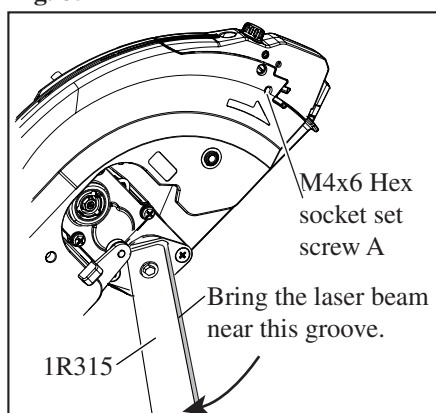
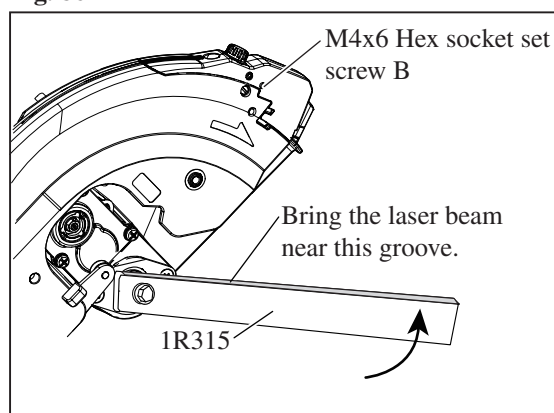


Fig. 86



- 9) Slide the position of M5x24 Thumb screw either right or left to align the laser beam and the groove of 1R315.  
And tighten M5x24 Thumb screw.
- 10) Move 1R315 to low side and align the laser beam and the groove of 1R315 by adjusting M4x6 Hex socket set screw A as illustrated in Fig. 85.
- 11) Move 1R315 to high side and align the laser beam and the groove of 1R315 by adjusting M4x6 Hex socket set screw B as illustrated in Fig. 86.
- 12) Do fine adjustment by repeating the process 9), 10) and 11).

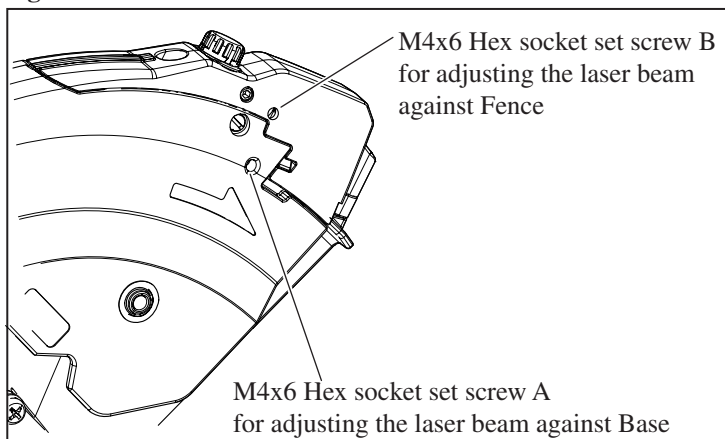
## ► Repair

### [4] ADJUSTMENT

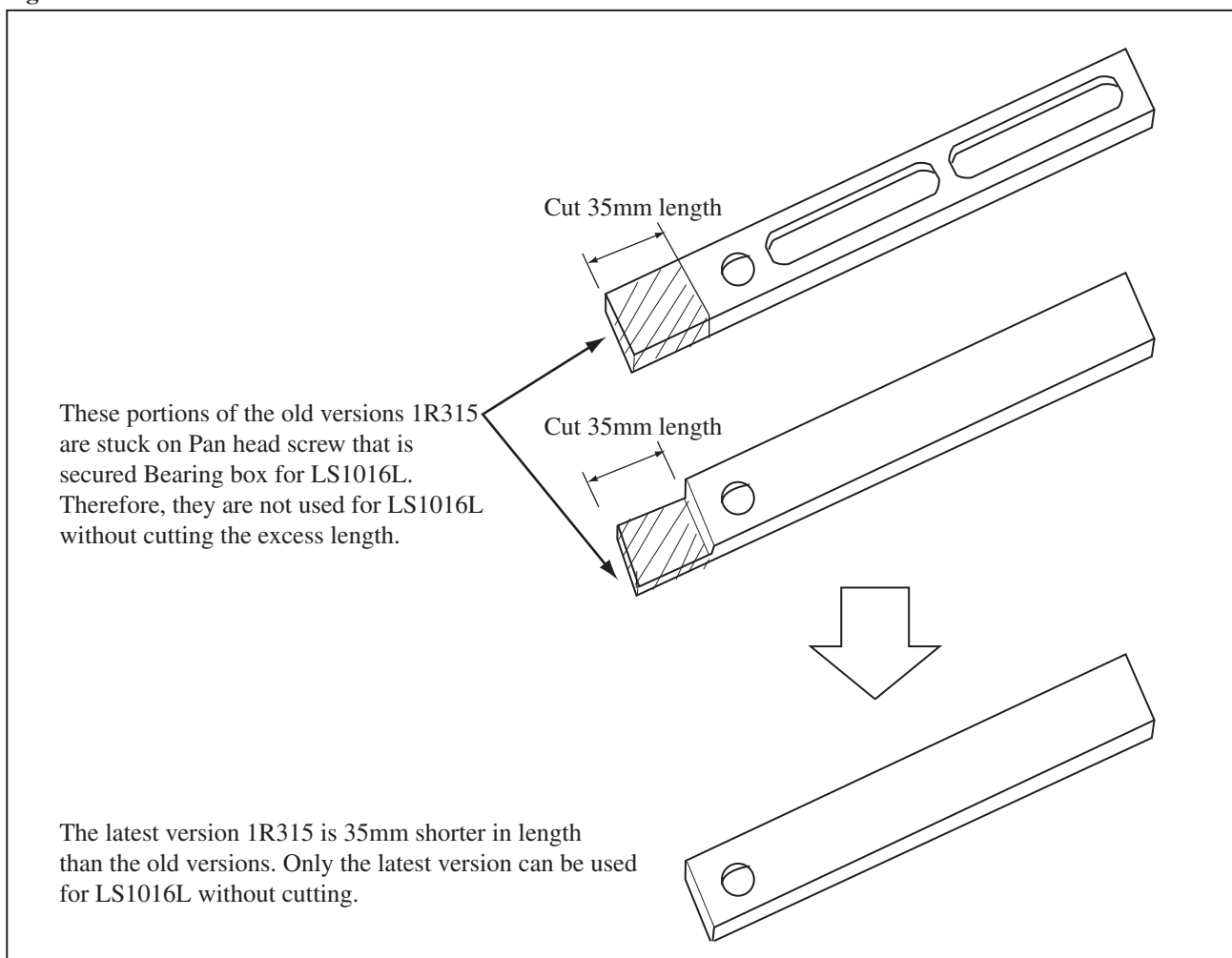
#### [4]-5. Laser (for LS1016L only: Cont.)

- Note:** 1) In the process 10) and 11), backlash of M4x6 Hex socket set screw A or B may be happened. Therefore, turn each M4x6 Hex socket set screw clockwise carefully to prevent backlash.
- 2) Be sure to distinguish the role of M4x6 Hex socket set screw A and M4x6 Hex socket set screw B.  
Refer to **Fig. 87**.
- 3) Repairing tool No. 1R315 has three different versions due to the production period. The latest version can be used.  
When using the old versions to adjust LS1016L, be sure to cut the excess length as illustrated in **Fig. 88**.

**Fig. 87**

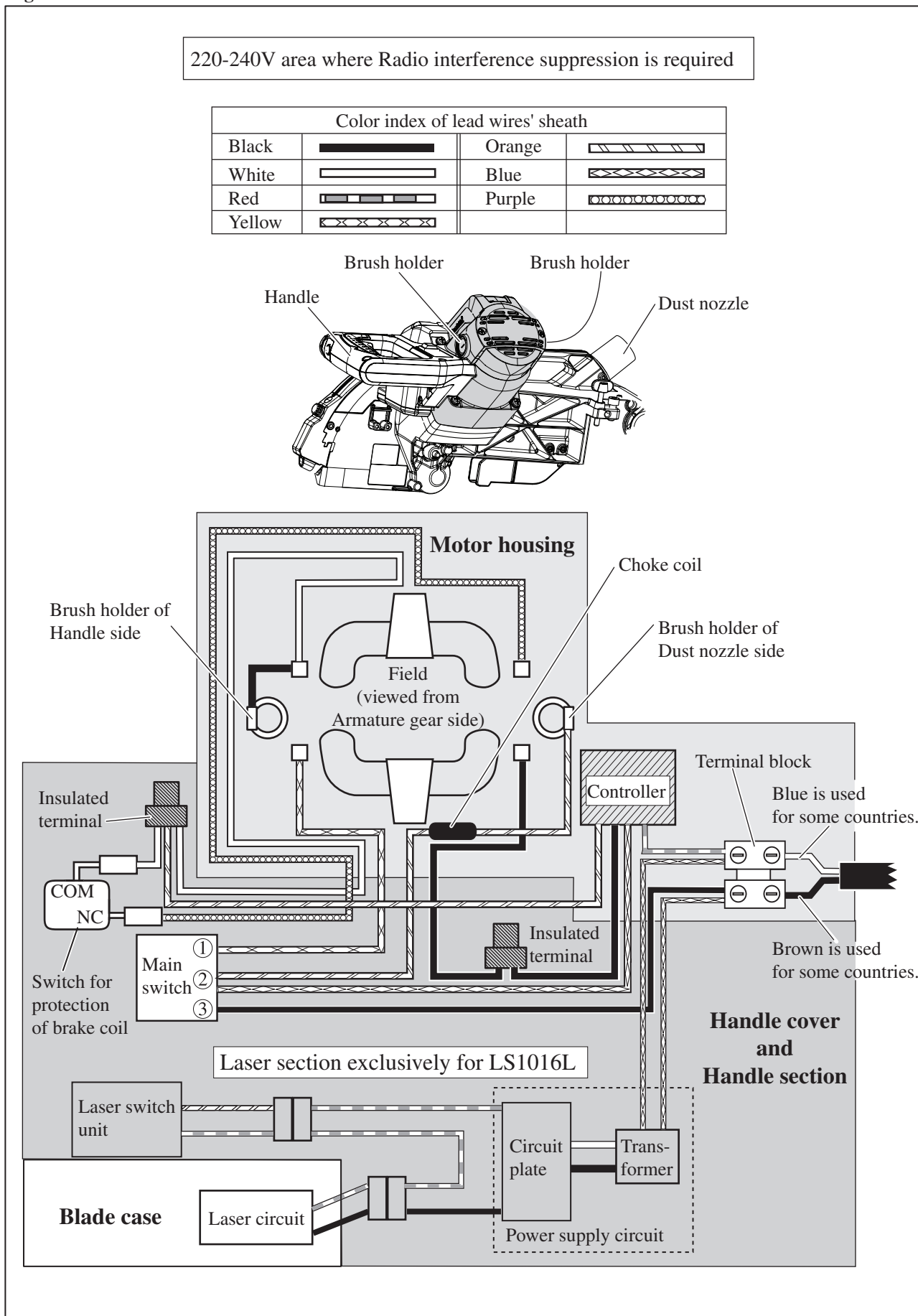


**Fig. 88**



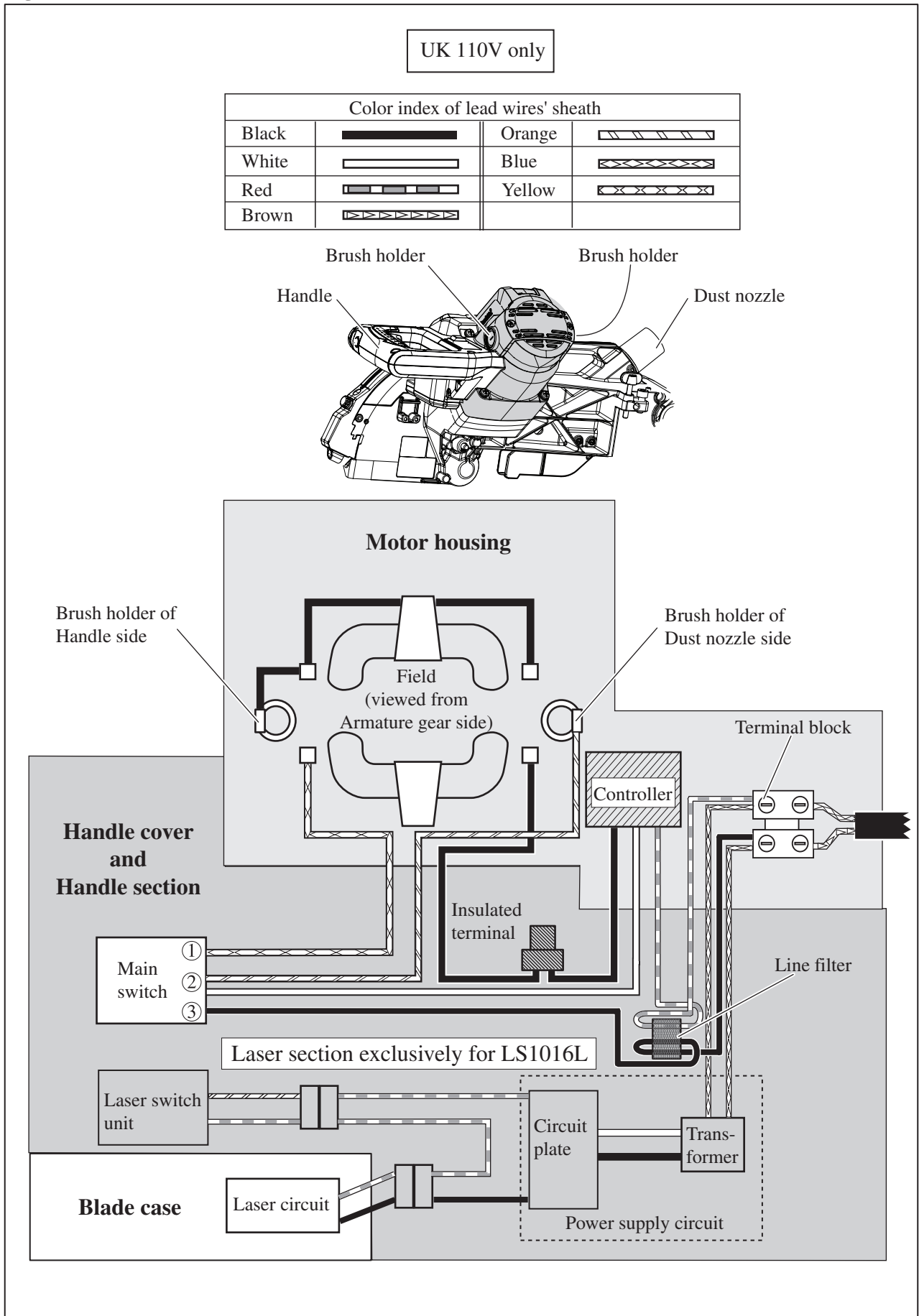
► **Circuit diagram**

Fig. D-1A



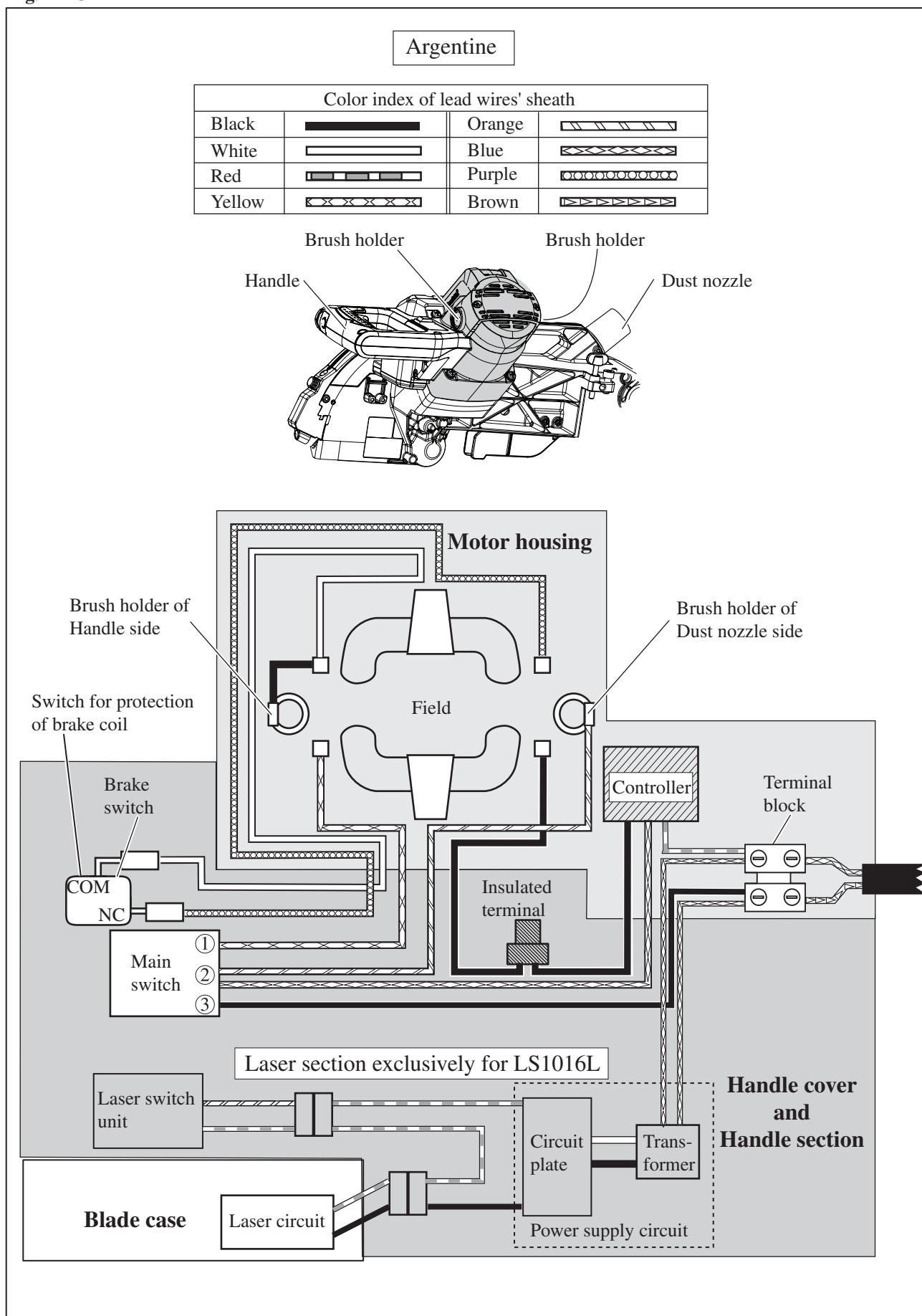
► **Circuit diagram**

Fig. D-1B



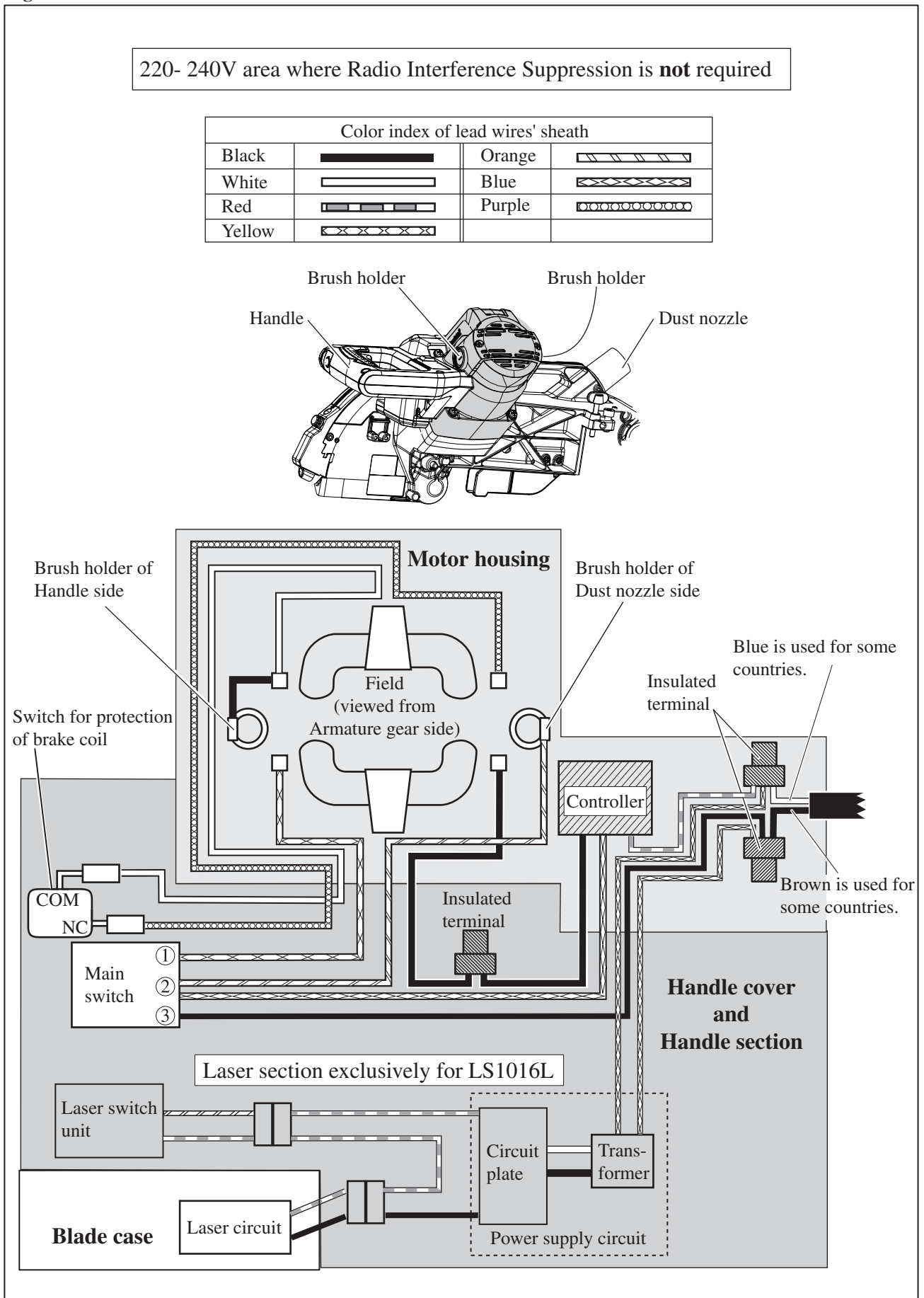
► **Circuit diagram**

**Fig. D-1C**



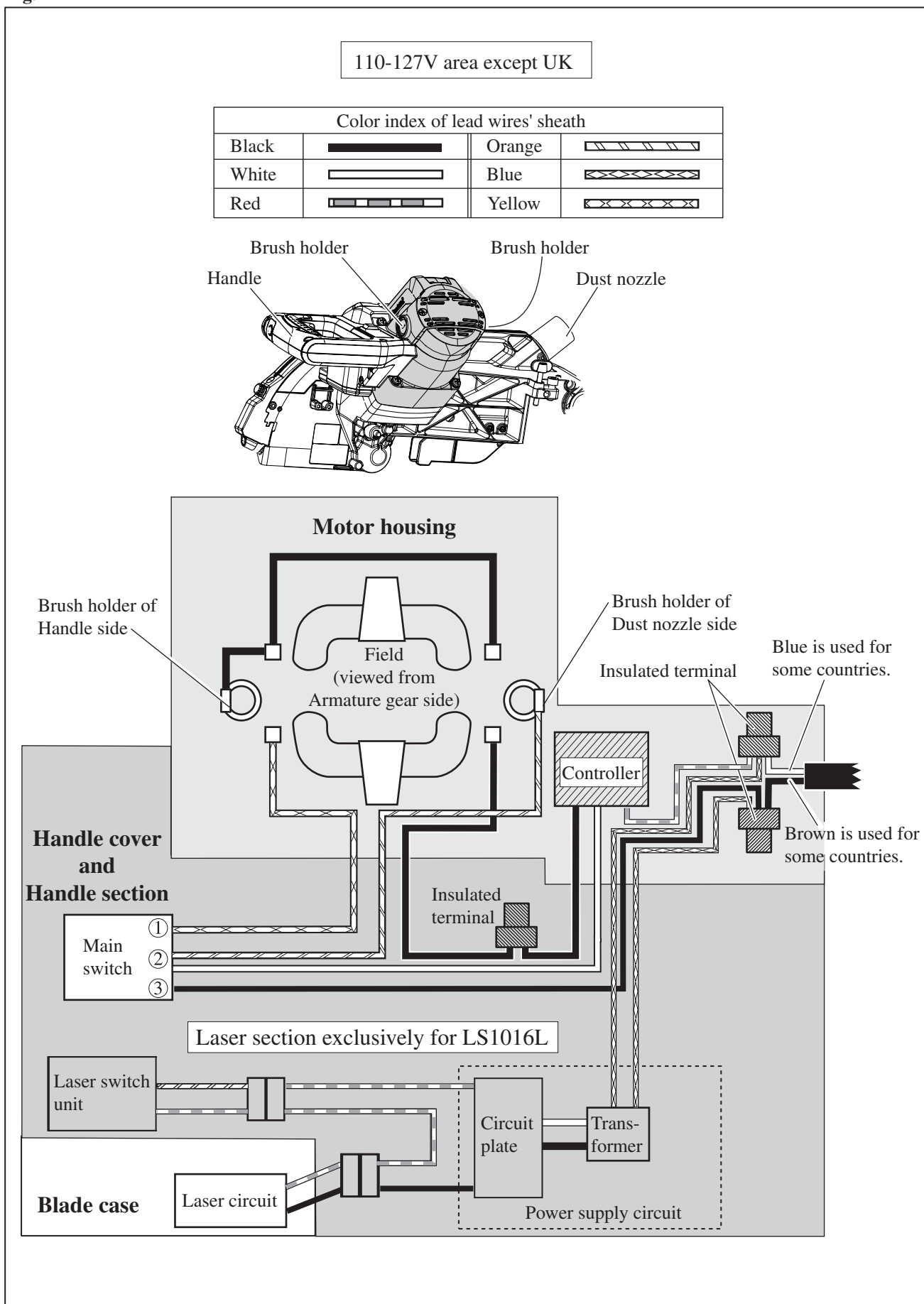
► **Circuit diagram**

Fig. D-1D



► **Circuit diagram**

Fig. D-1E



► **Wiring diagram**

Wiring around Case of LS1016L

Fig. D-3

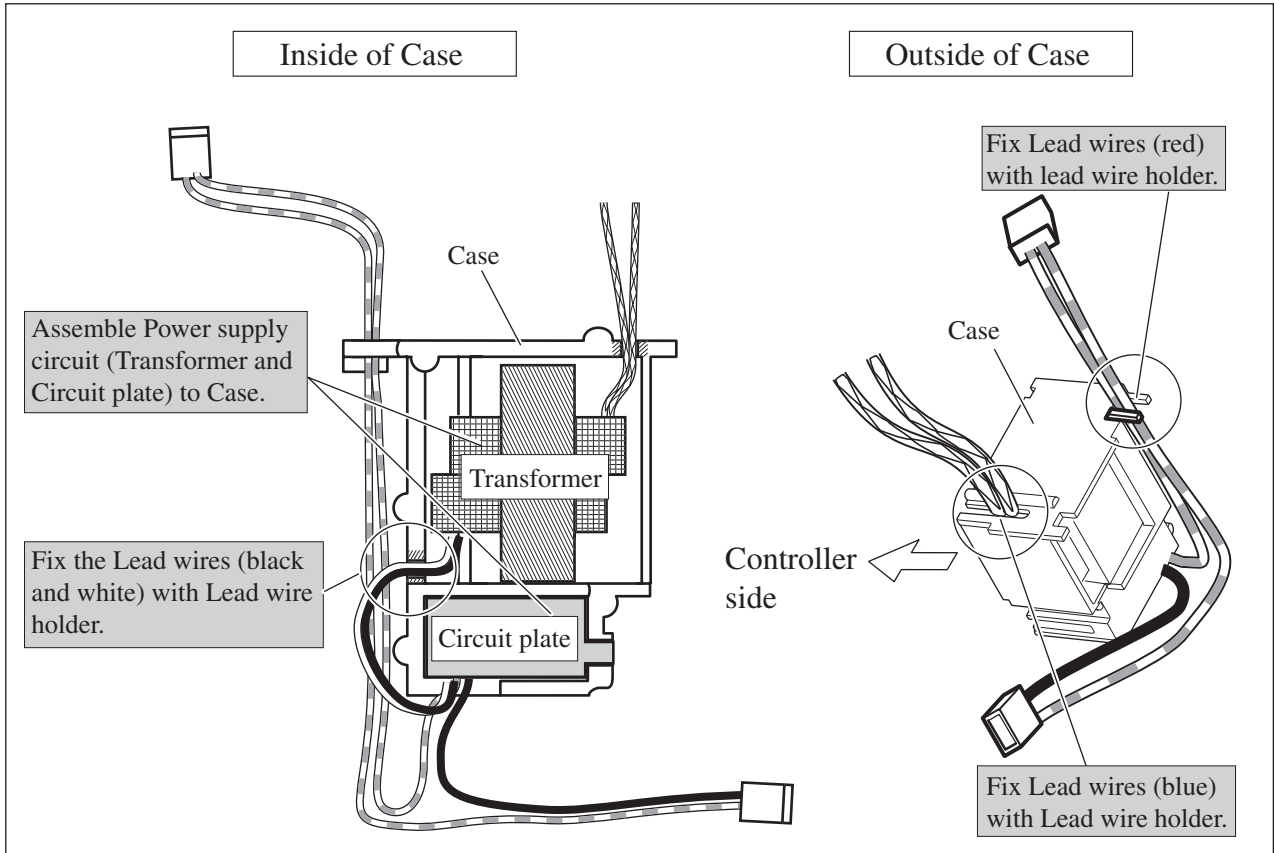
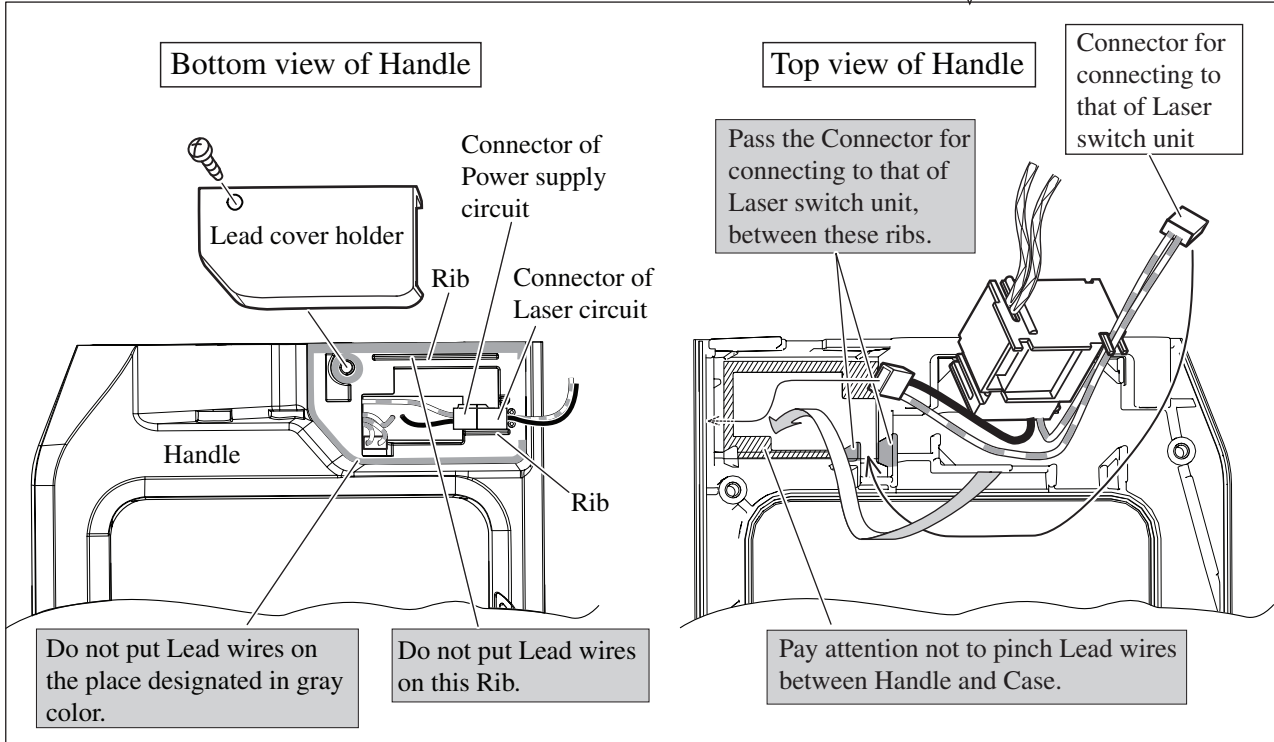


Fig. D-4



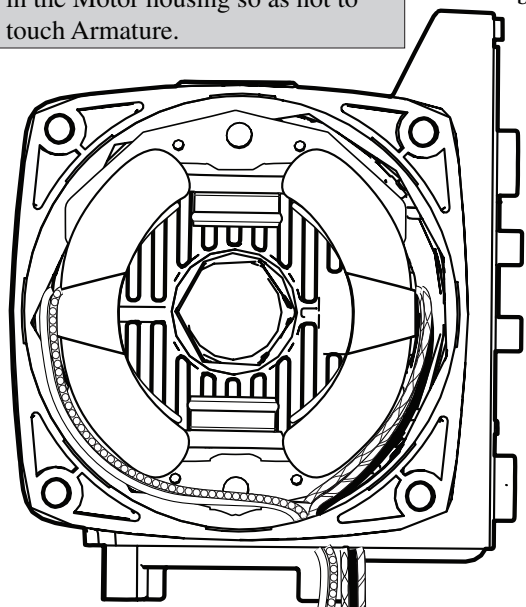


# ▶ Wiring diagram

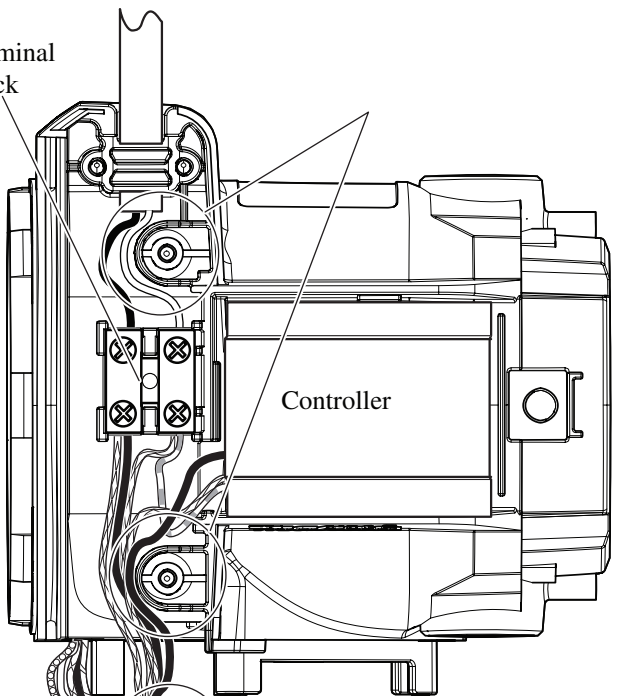
Fig. D-2A

Wiring in Motor Housing and Handle for Argentina and 220 - 240V area where Radio interference suppression is required.

Field lead wires have to be tightened in the Motor housing so as not to touch Armature.

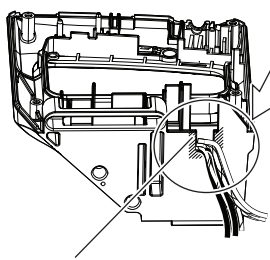


Terminal block

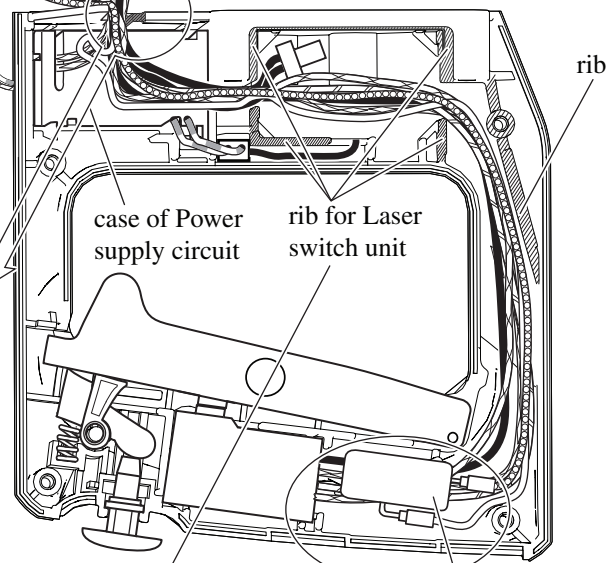


Do not route Field lead wires (white and purple) between Armature and Baffle plate.

Field lead wires  
\* (orange)  
\* (black)  
\* (yellow)



Pass the Lead wires from Motor housing through this notch of Handle.

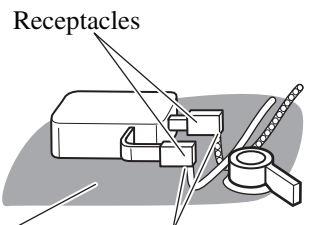


Pass Lead wires through ribs as illustrated. Do not put Lead wires on ribs.

Switch for protection of brake coil

## Connection of Receptacles

The Receptacles have to be connected so that their wire connecting portions face the bottom of Handle.

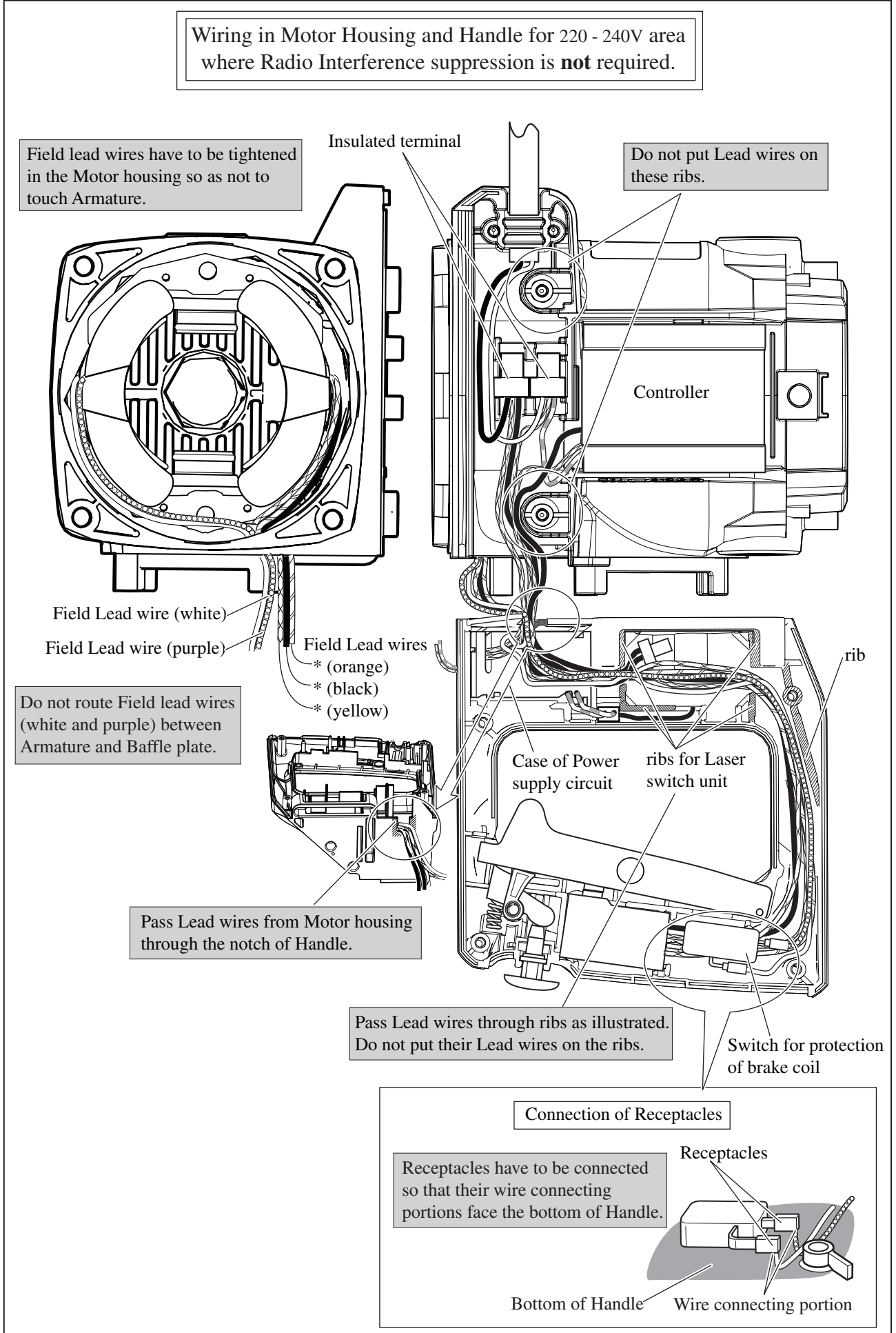


Bottom of Handle

Wire connecting portion

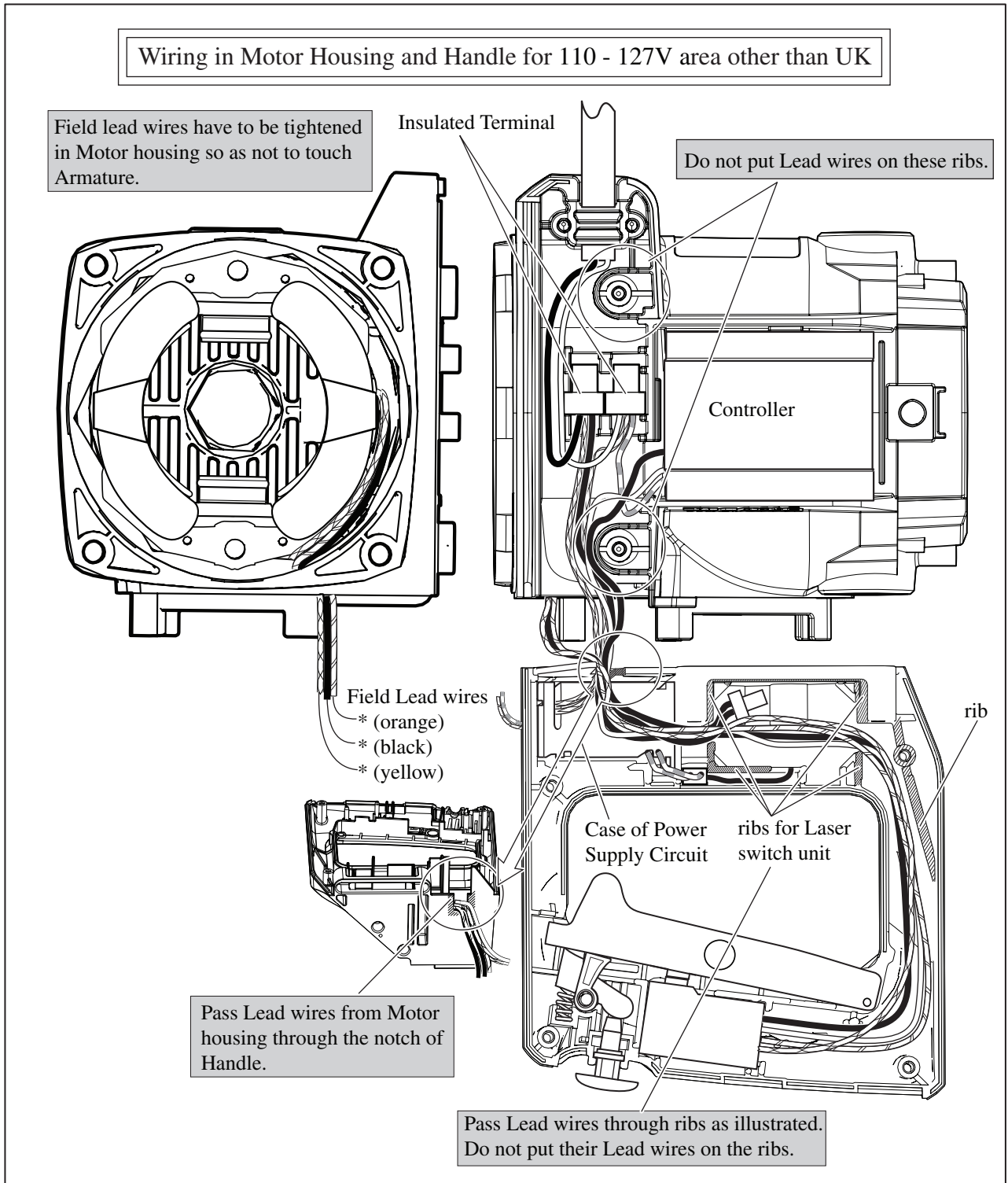
# ▶ Wiring diagram

Fig. D-2D



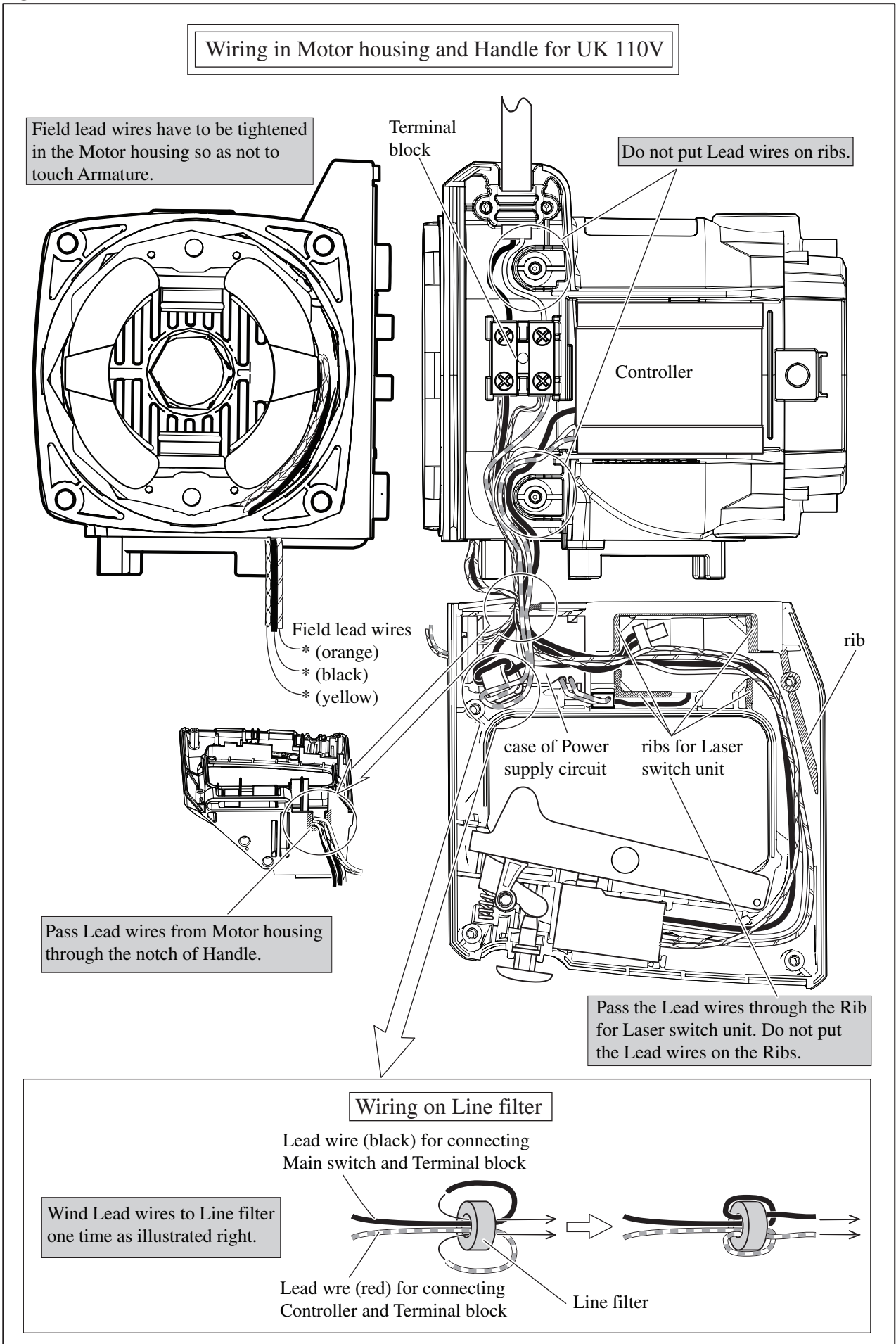
► **Wiring diagram**

Fig. D-2E



# ▶ Wiring diagram

Fig. D-2B



► **Wiring diagram**

Fig. D-5

