

TECHNICAL INFORMATION

- Models No.** ▶ DP3002
DP3003
- Description** ▶ 10mm (3/8") Drill
10mm (3/8") Drill with Keyless drill chuck

Dimensions : mm (")		
Model No.	DP3002	DP3003
Width (W)	72 (2-13/16)	
Height (H)	196 (7-3/4)	
Length (L)	304 (12)	296 (11-5/8)

CONCEPTION AND MAIN APPLICATIONS

The above models have been developed for heavy duty work of professional users.

Their brief features and benefits are

- * Durable and robust aluminum gear housing
- * High power and high torque

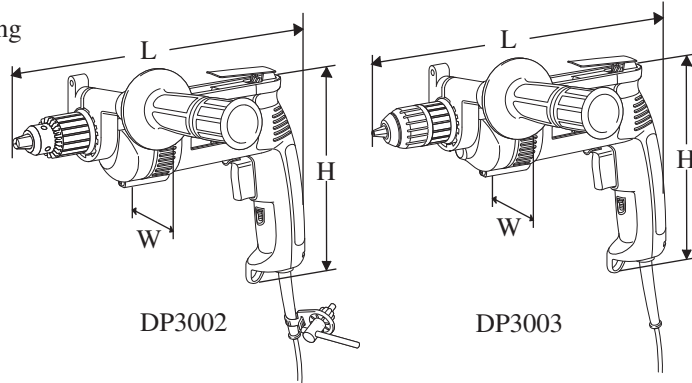

► Specification

Voltage (V)	Current (A)	Cycle (Hz)	Continuous Rating (W)		Max. Output(W)
			Input	Output	
110	6.8	50/60	710	330	640
120 (UL)	7.0	50/60	(800)	330	640
220	3.4	50/60	710	330	640
230	3.2	50/60	710	330	640
240	3.1	50/60	710	330	640

Model No.	DP3002	DP3002K	DP3003	DP3003K
No load speed : (min - max rpm)	0 - 1,200			
Keyless chuck	No		Yes	
Chuck ability : mm (")	1 - 10 (1/32 - 3/8)		0.8 - 10 (1/32 - 3/8)	
Drilling capacity : mm (")	in Steel	10 (3/8)		
	in Wood	32 (1-1/4)		
Reverse switch	Yes			
Protection from electric shock	by double insulation			
Plastic carrying case	No	Yes	No	Yes
Cord length : m (ft)	2.5 (8.2)			
Net weight :Kg (lbs)	2.0 (4.4)		1.8 (3.9)	

► Standard equipment

- * Grip assembly 1 set
- * Chuck key 10 1 pc. (only for DP3002)
- * Key holder 12 1pc. (only for DP3002)

< Note > The standard equipment for the tool shown may differ from country to country.

► Optional accessories

- Drill bit 1.5, 2, 3, 4, 5, 6
- Drill bit for wood 9, 12, 15
- Depth gauge (Stopper pole)
- Drill stand type 43
- Plastic carrying case (only for DP3002K and DP3003K)

▶ Repair

< 1 > Lubrication

Apply MAKITA Grease N No.1 to the portion illustrated in Fig. 1. Turn the gears in order to spread the grease into gear housing and on the gears, when applying.

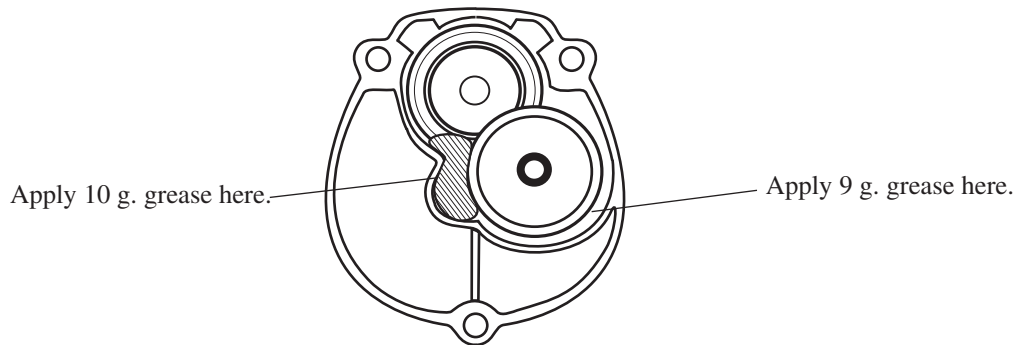

Fig. 1

< 2 > Disassembling spindle section

(1) Disassembling helical gear 32

Remove retaining ring S-10 from spindle. Then, helical gear 32 can be removed from spindle. See Fig. 2.

(2) Disassembling spindle

Remove retaining ring S-15 from spindle. Then, spindle can be removed from gear housing. See Fig. 2.

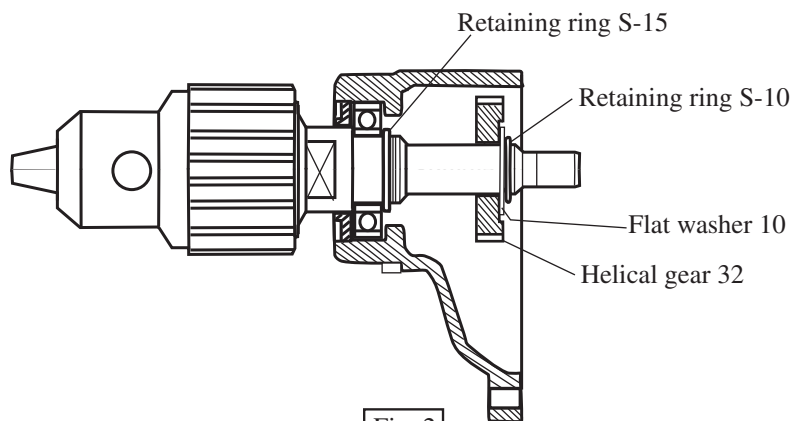

Fig. 2

Repair

< 3 > Disassembling bearing retainer 22-36

(1) Remodeling 1R043 "Wrench for bearing retainer"

The following repairing tool is not available for DP4000 series models without remodeling.
It has to be remodeled by changing the size A from 20 mm to 24 mm as illustrated in Fig. 3.

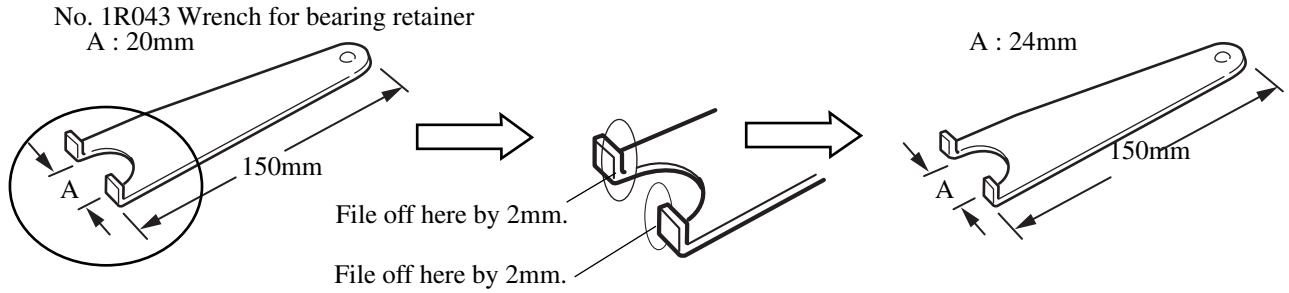

Fig. 3

(2) Disassembling bearing retainer 22-36

Set the hook of remodeled "wrench for bearing retainer" in the groove of bearing retainer 22-36 and turn it with the remodeled wrench clockwise as illustrated in Fig. 4.

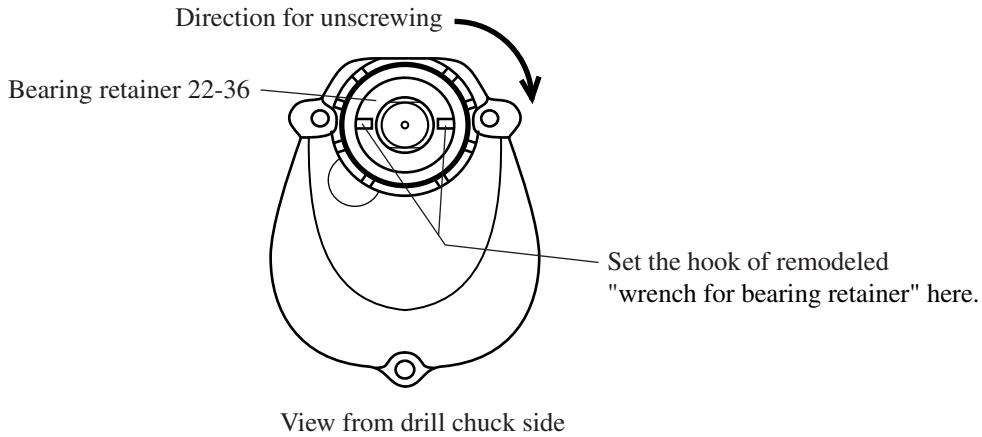

Fig. 4

< 4 > Disassembling ball bearing 626LLB

Hit the portion illustrated in Fig. 5 with small plastic hammer. Then ball bearing 626LLB comes out from gear housing.

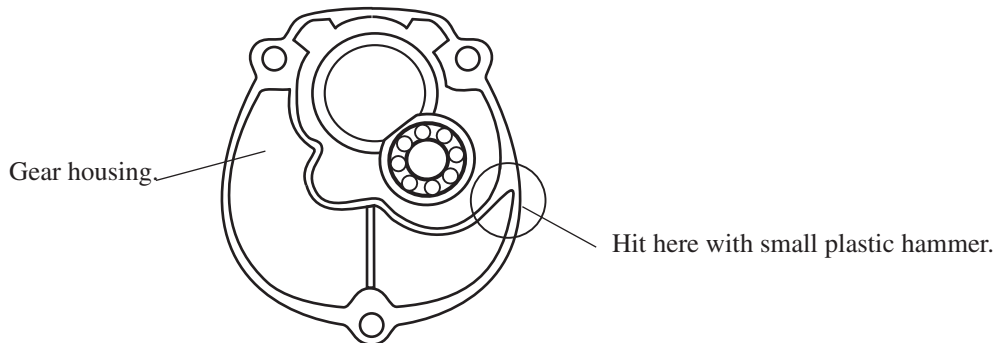

Fig. 5

Repair

< 5 > Assembling bearing retainer 22-36

Set the hook of remodeled "wrench for bearing retainer" in the groove of bearing retainer 22-36 and turn it with the remodeled wrench anti-clockwise as illustrated in Fig. 6.

The fastening torque for bearing retainer 22-36 is approx. 11.8 - 15.7 N.m (120 - 160 Kgf.cm).

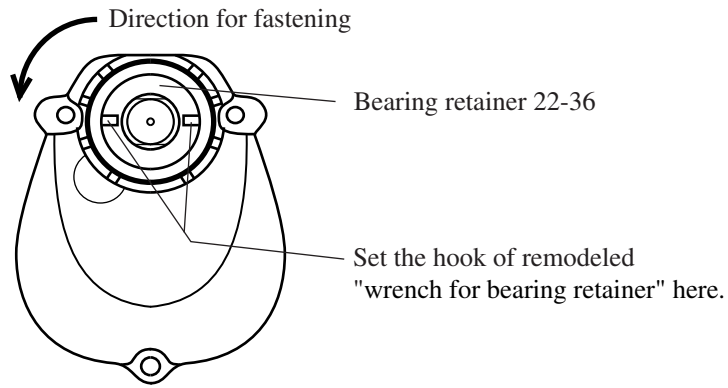

View from drill chuck side

Fig. 6

< 6 > Assembling drill chuck

Lock spindle by gripping the flat part of spindle with 1R139 "Drill chuck extractor".

And gripping hex wrench with drill chuck firmly, fasten drill chuck by turning the gripped hex wrench as illustrated in Fig. 7. The fastening torque for drill chuck is approx. 63.7 - 68.6 N.m (650 - 700 Kgf.cm).

1R139 Drill chuck extractor

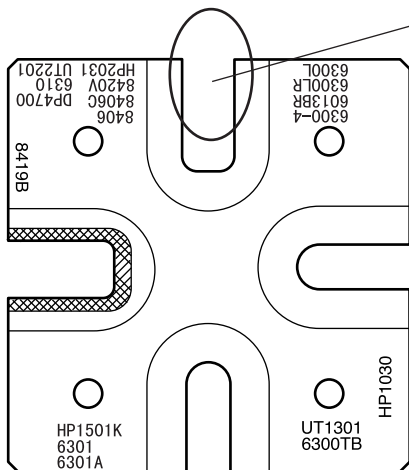

Grip the flat part of spindle with this portion where is marked with "DP4700"

Drill Chuck Extractor

Hex wrench

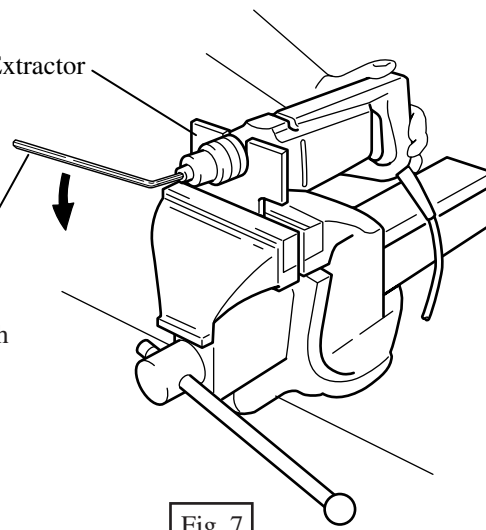

Fig. 7

< 7 > Assembling helical gear 32

Assemble helical gear 32 to spindle, facing its concave portion to motor housing side, as illustrated in Fig. 8.

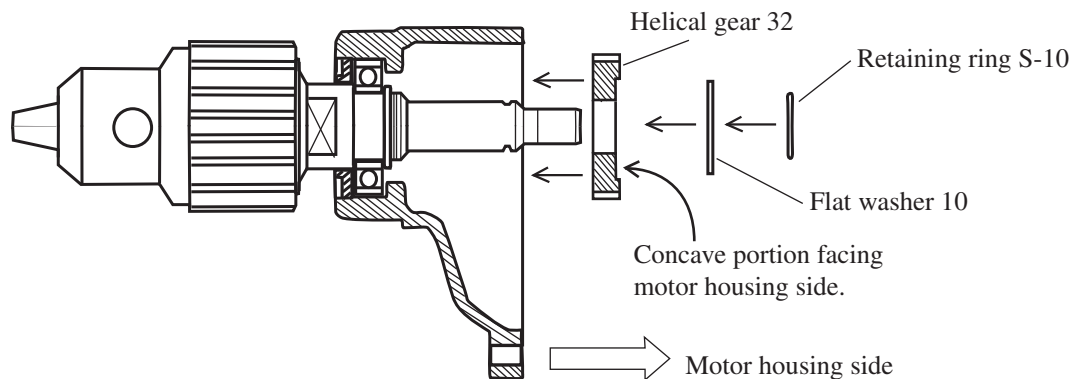
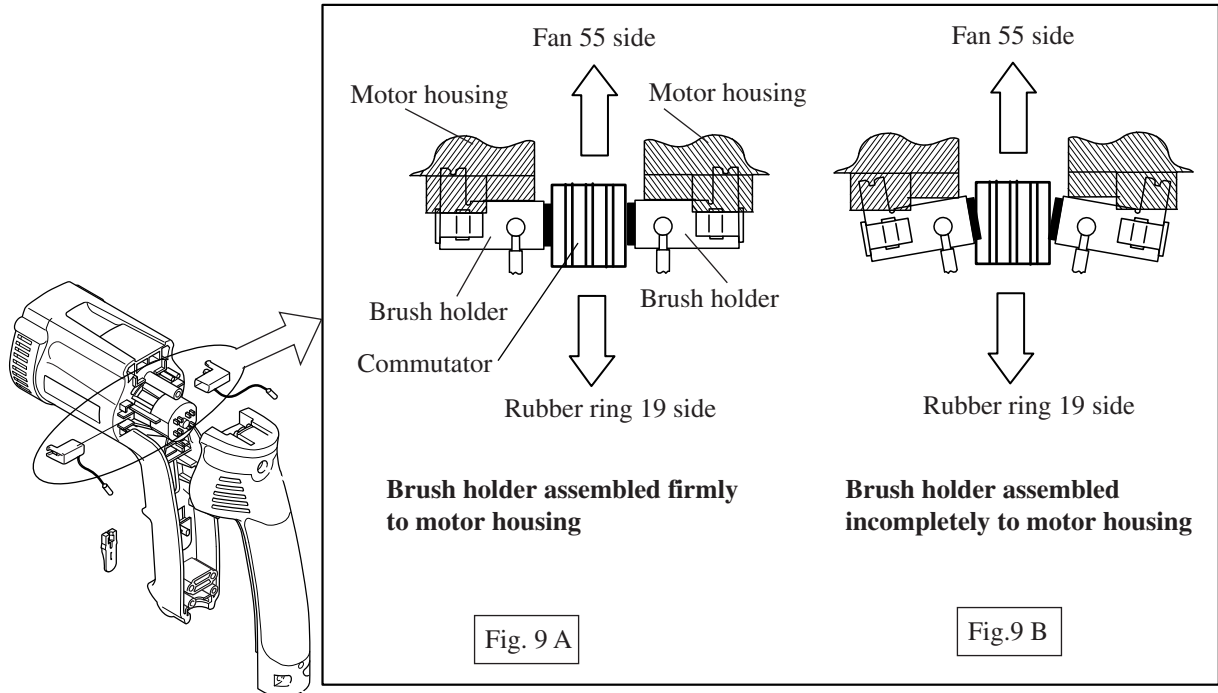

Fig. 8

< 8 > Assembling brush holder

Assemble brush holder to motor housing firmly as illustrated in Fig. 9A. Always make sure, whether the brush holder is assembled as illustrated in Fig.9A, before mounting handle cover to the motor housing.



< 9 > Assembling slide lever

- 1) Assemble switch, meeting its lever to the groove of slide lever as illustrated in Fig. 10.
- 2) Make sure that slide lever can slide smoothly after the following process.
 - * Mounting switch, or putting lead wires in the grip
 - * Mounting handle cover

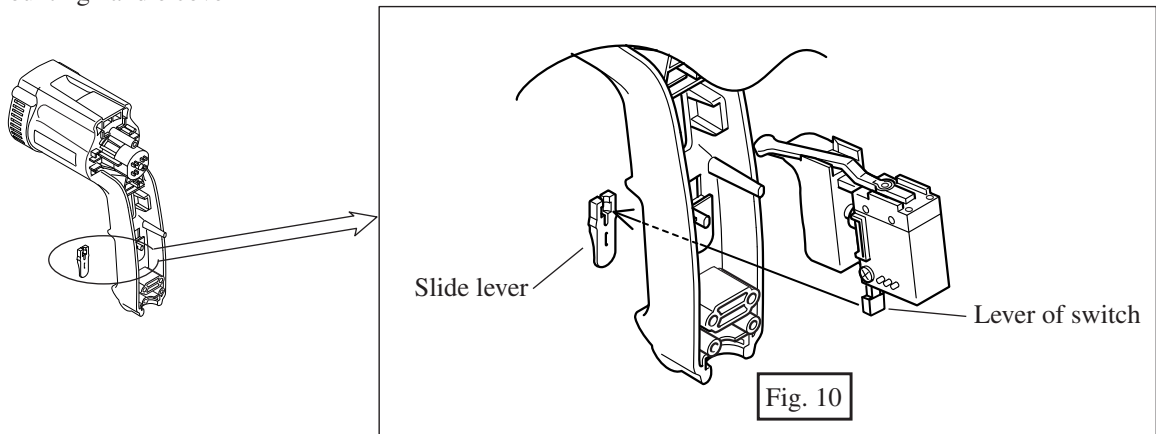

< 10 > Screwing tapping screws

Fasten the tapping screws as illustrated in Fig. 11.

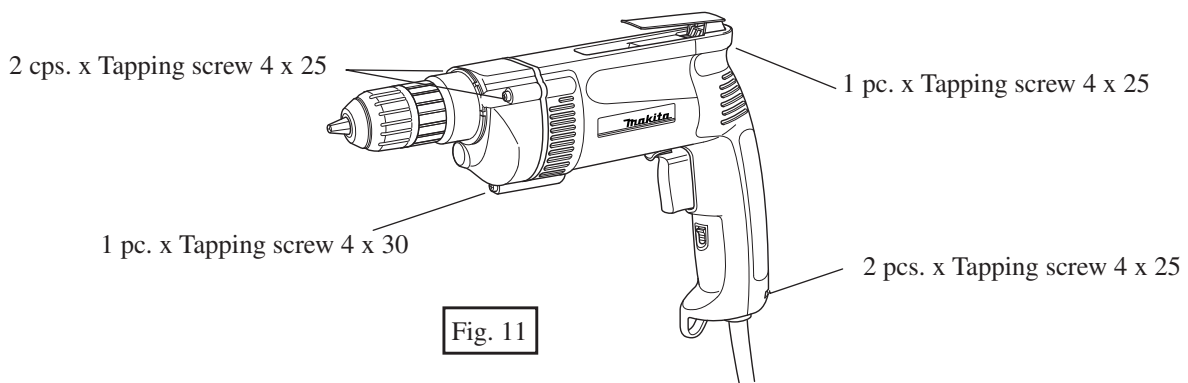

▶ Wiring diagram

(1) Without line coil

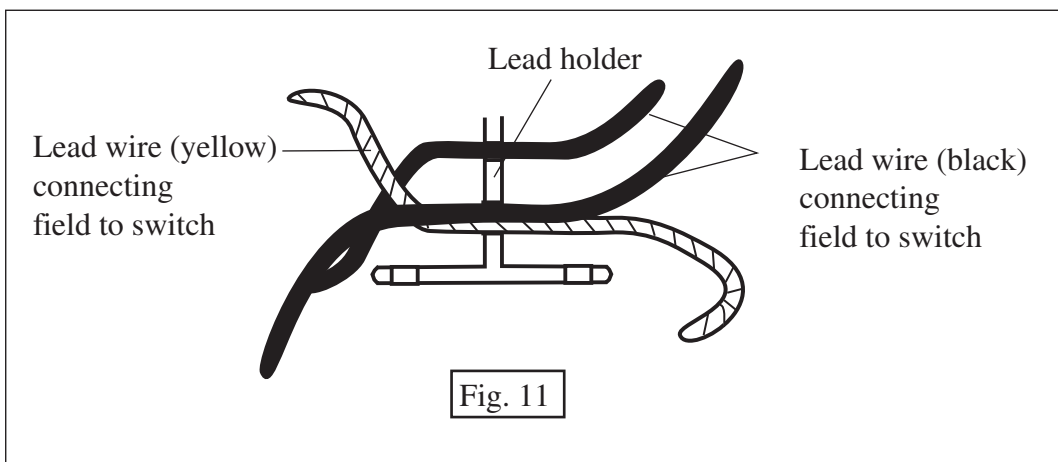
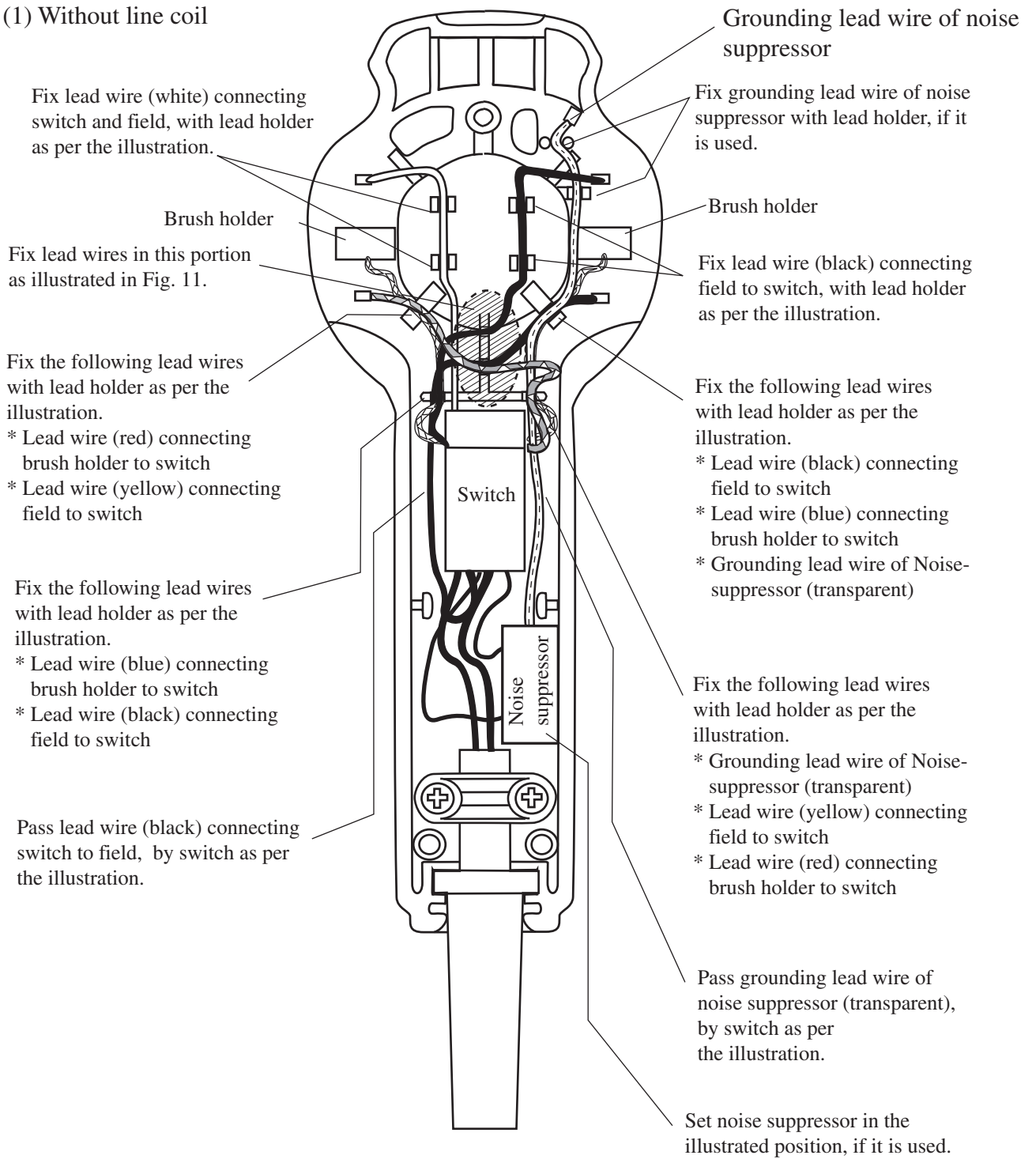

(2) With line coil

