

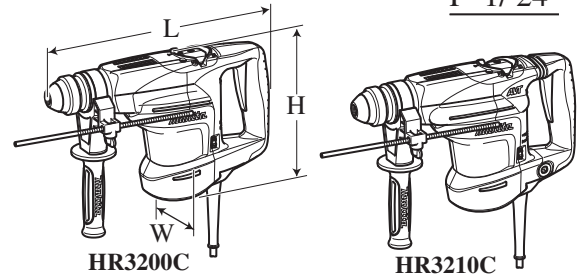
# TECHNICAL INFORMATION

**Model No.** ▶ HR3200C, HR3210C, HR3210FCT

**Description** ▶ Rotary Hammer 32mm (1-1/4")

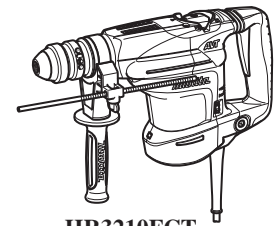
## CONCEPT AND MAIN APPLICATIONS

HR3200C series models have been developed as successor models of HR3000C, featuring low vibration level and lightweight design. Listed below are specification differences among the three models.



HR3200C

HR3210C



HR3210FCT

Model No.	HR3200C	HR3210C	HR3210FCT
AVT	No	Yes	Yes
Active dynamic vibration absorber			
Vibration absorbing handle	No	No	Yes
Quick change drill chuck	No	No	Yes
LED Job light	No	No	Yes

Dimensions: mm (")			
Model No.	HR3200C	HR3210C	HR3210FCT
Length (L)	398 (15-5/8)		424 (16-3/4)
Width (W)	108 (4-1/4)	114 (4-1/2)	
Height (H)	239 (9-3/8)		

## ► Specification

Voltage (V)	Current (A)	Cycle (Hz)	Continuous Rating (W)		Max. Output (W)
			Input	Output	
110	8.6	50/60	850	300	1,100
120	8.2	50/60	---	300	1,100
220	4.4	50/60	850	300	1,100
230	4.4	50/60	850	300	1,100
240	4.4	50/60	850	300	1,100

Specification	Model	HR3200C	HR3210C	HR3210FCT
No load speed: min.= rpm			315 - 630	
Impacts per minute: min.= ipm			1,650 - 3,300	
Shank type			SDS-plus	
Capacities: mm (")	Concrete	TCT bit	32 (1-1/4)	
		Core bit	90 (3-1/2)	
	Steel	13 (1/2)		
	Wood	32 (1-1/4)		
Operation mode		3 modes (Rotation only/ Rotation with Hammering/ Hammering only)		
Torque limiter		Yes		
Electronic features	Variable speed control by dial	Yes		
	Soft start	Yes		
	Constant speed control	Yes		
Double insulation		Yes		
Power supply cord (m: ft)		Europe: 4.0 (13.1), Brazil: 2.0 (6.6), Other countries: 5.0 (16.4)		
Net weight: kg (lbs)		4.4 (9.7)	4.8 (10.6)	5.0 (11.0)

## ► Standard equipment

Side handle (Bar-shaped) .... 1 Grease vessel 93G (containing Bit grease) ..... 1 Plastic carrying ..... 1  
Depth gauge ..... 1 Quick change drill chuck (for HR3210FCT only) ..... 1

**Note:** The standard equipment for the tool shown above may differ by country.

## ► Optional accessories

TCT bits (taper shank), Taper shank adapter, Cotter, Core bits, Center bit, Core bit adapter, Rod, Bull points, Cold chisels, Scaling chisels, Grooving chisels, Scraper assembly, Dust cups 5 and 9, Drill chuck assembly, Drill chuck adapter, Drill chuck S13, Chuck key S13, Depth gauge, Blow-out bulb, Grease vessel (containing 30g of Hammer grease), Grease vessel 93G (Containing Bit grease), Safety goggle, Hammer service kit, Quick change drill chuck (for HR3210FCT only)

## ► Repair

**CAUTION: Unplug the tool and remove the bit for safety before repair/ maintenance in accordance with the instruction manual!**

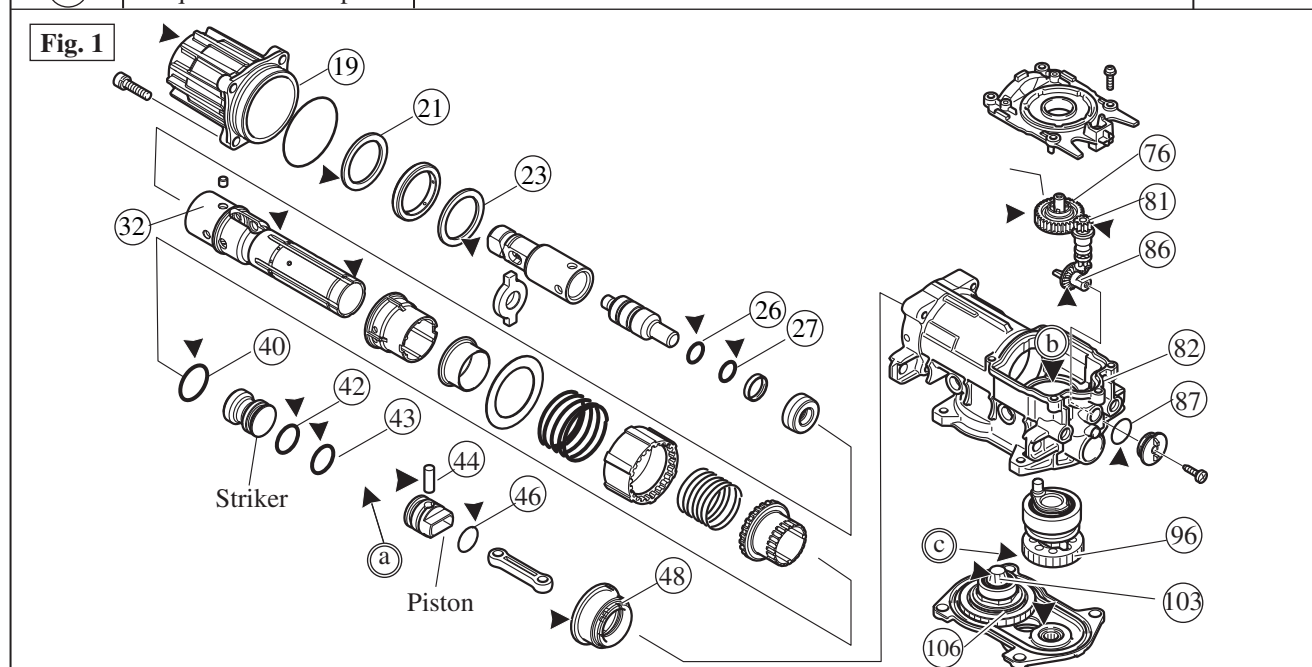
### [1] NECESSARY REPAIRING TOOLS

Code No.	Description	Use for
1R003	Retaining ring S pliers ST-2N	Removing / Assembling Ring spring 19
1R045	Gear extractor (large)	Removing Armature from Gear housing
1R346	Center attachment for 1R045	
1R212	Tip for Retaining ring pliers	Tip for Retaining ring pliers
1R288	Screwdriver magnetizer	Magnetizing Screwdriver when removing Pin and Steel ball
1R230	1/4" Hex. shank bit for M6	Removing Hex socket head bolt M6x25 for tightening Barrel complete
1R259	Taper sleeve	Fitting Fluoride ring to Impact bolt
1R269	Bearing extractor	Removing Ball bearings

### [2] LUBRICATION

Apply Makita grease R. No.00 (Part No. 181490-7: Hammer grease 30g) to the following portions designated with the black triangle to protect parts and product from unusual abrasion.

Item No.	Description	Portion to lubricate	Amount
①9	Barrel complete	Inner periphery of Oil seal 28 (the component of Barrel complete) Inner surface of Plane bearing 34 (the component of Barrel complete)	a little
②1	Flat washer 34	Bit installation side	
②3	Flat washer 34	Crank housing side	
④0	O ring 26	Whole portion	
④2 ④3	O ring 18	Whole portion	
④4	Pin 7	Whole portion	2g
③2	Cylinder 25	Outer surface Between Striker and Piston in Cylinder 25 (a)	
④8	Spiral bevel gear 37	Gear teeth	total 13g
⑦6	Spur gear 33 complete	Gear teeth	
⑧1	Gear shaft	Gear teeth	
⑧6	Crank gear	Gear teeth	
⑧2	Crank housing complete	Crank room (b)	a little
⑧7	O ring 16	Whole portion	
⑨6	Spiral bevel gear 9	Gear teeth (c)	total 13g
⑩3	Spur gear 33	Gear teeth	
⑩6	Torque limiter complete	Gear teeth	



## ► Repair

### [2] LUBRICATION (Cont.)

Regarding HR3210C and HR3210FCT, apply a little bit amount of Makita grease R. No.00 (Part No. 181490-7: Hammer grease 30g) to the following portions of AVT mechanism designated by black triangle.

Item No.	Description	Portion to lubricate
(50)(63)	O ring 8	Whole portion
(52)(61)	O ring 8	Whole portion
(55)(57)	O ring 18	Whole portion
(58)	Counter weight	Drum portion

**Fig. 2**

**AVT for HR3210C, HR3210CT**

Apply a little bit amount of Makita grease N. No.2 (Part No. 181573-3: Grease vessel 93g) to the following portions designated with the gray triangle.

Item No.	Description	Portion to lubricate
(2)	Tool holder cap	Lip portion
(6)	Steel ball 7	Whole portion
(10)	Steel ball 6	Whole portion

**Fig. 3**

**HR3210FCT**

**HR3200C, HR3210C**

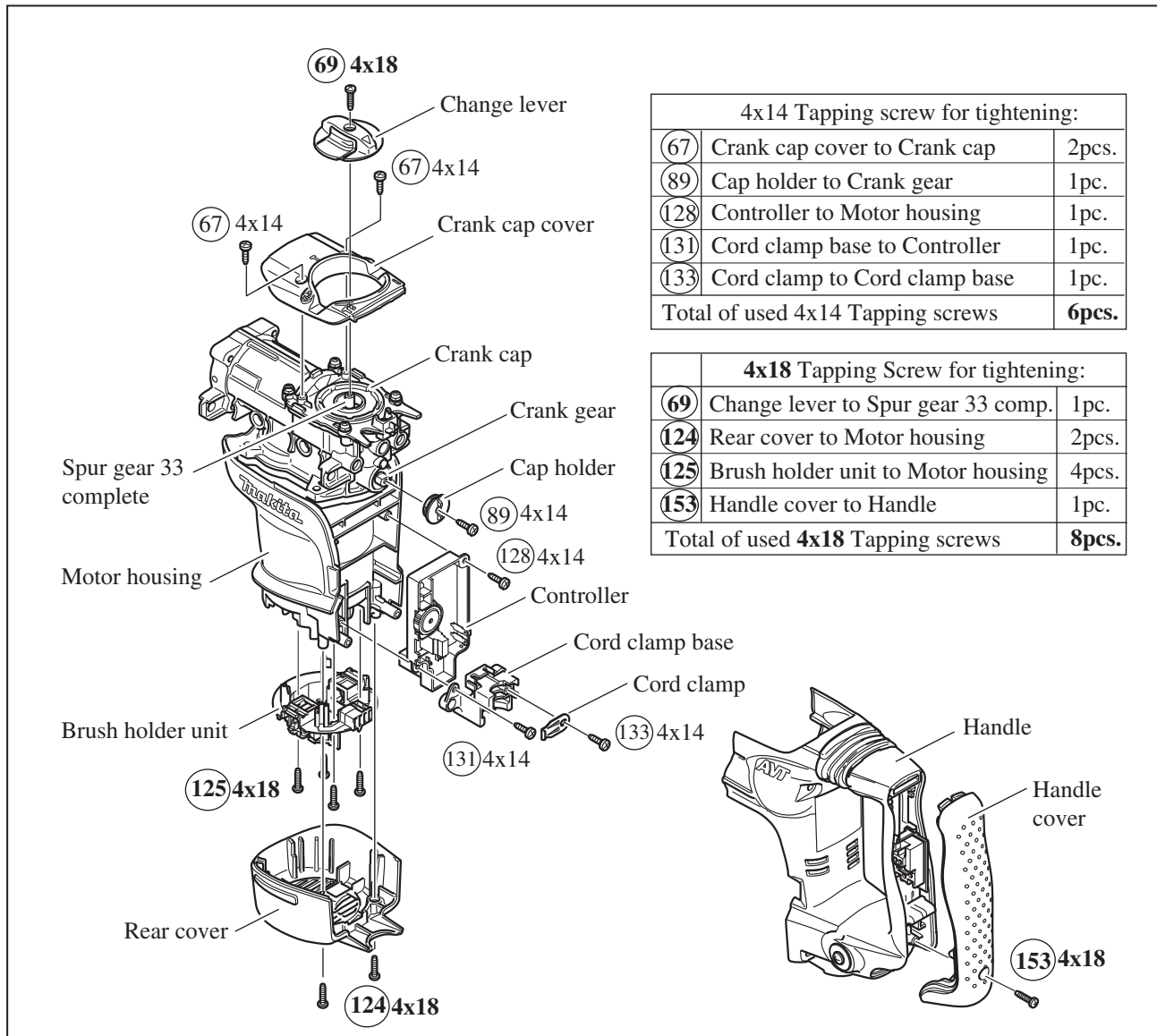
► **Repair**

**[3] DISASSEMBLY/ASSEMBLY**

**[3] -1. Tapping Screws**

4x14 and 4x18 Tapping screws are used as illustrated in **Fig. 4**.  
Pay attention not to confuse their positions.

**Fig. 4**



► **Repair**

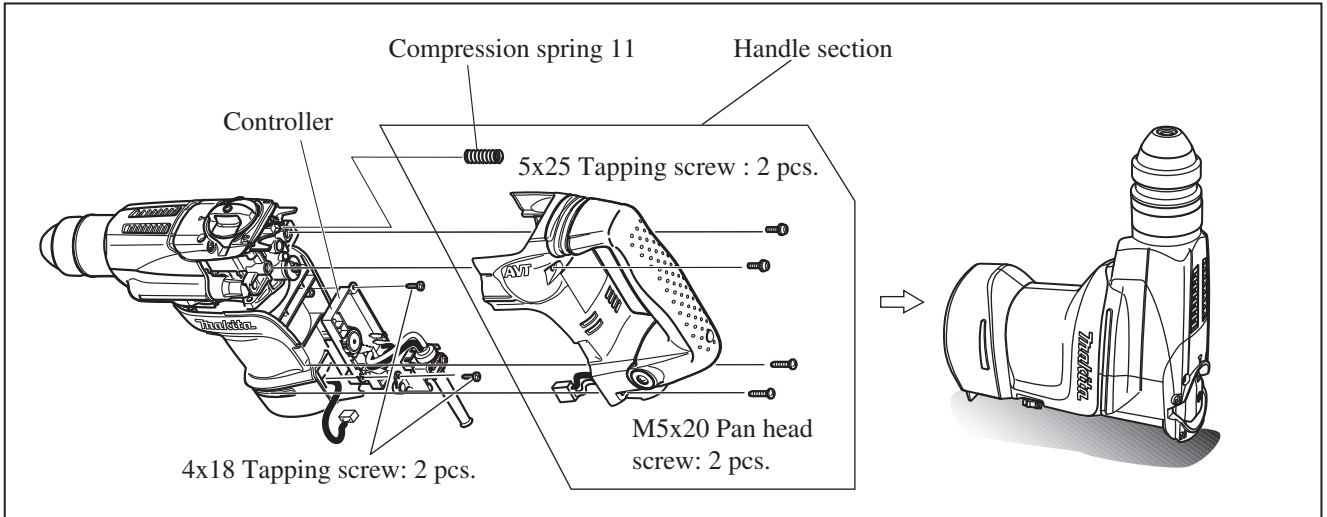
**[3] DISASSEMBLY/ASSEMBLY**

**[3] -1. Chuck Section (Model HR3200, HR3210C)**

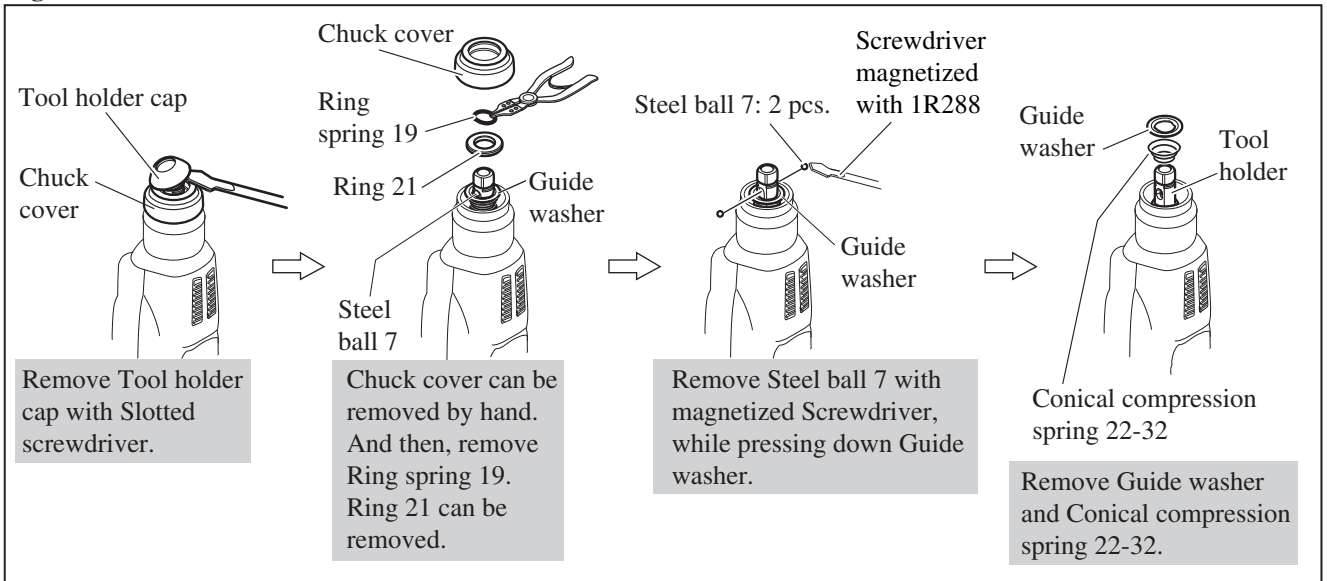
**DISASSEMBLY**

- 1) Remove Controller and Handle section and then upright the machine as illustrated in **Fig. 5**.
- 2) Disassemble Chuck section as illustrated in **Fig. 6**.

**Fig. 5**



**Fig. 6**

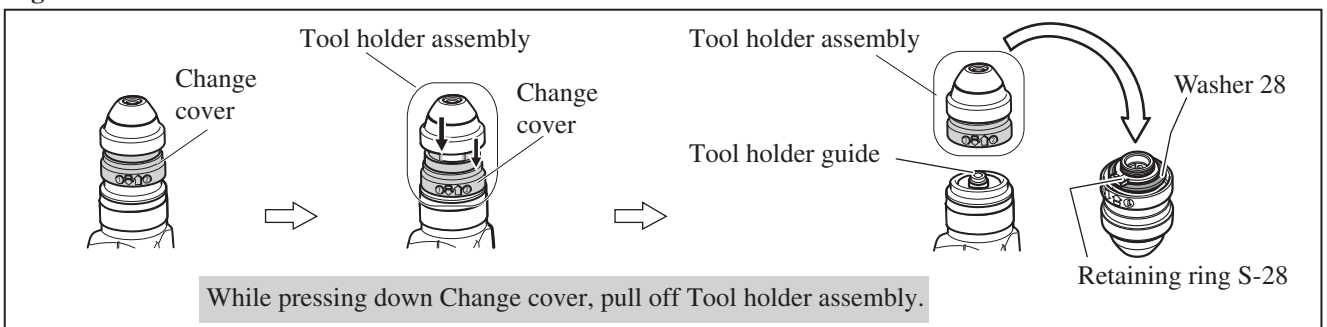


**[3] -1A. Chuck Section (Model HR3210FCT)**

**DISASSEMBLY**

- 1) Remove Handle section and then upright the machine. (**Fig. 5**) Separate Tool holder assembly from the Machine. (**Fig. 7**)

**Fig. 7**



► **Repair**

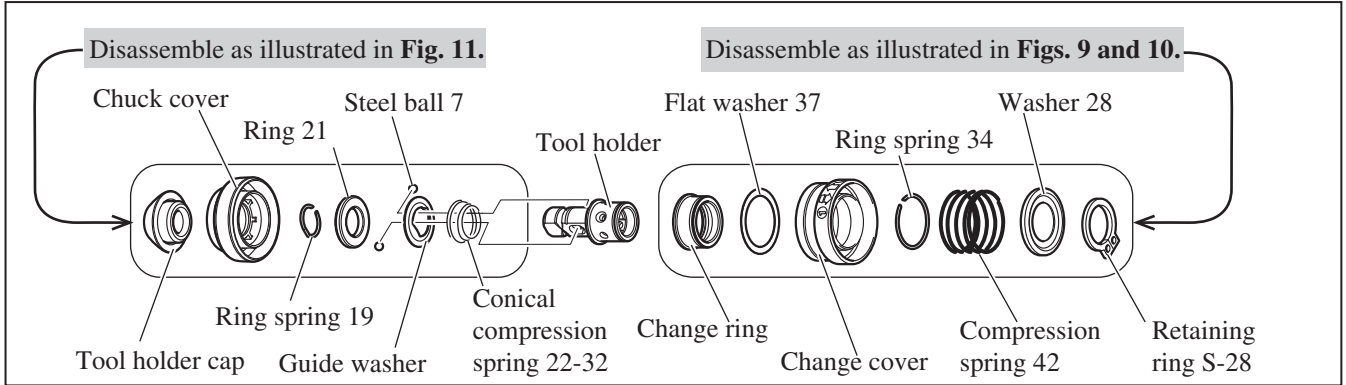
**[3] DISASSEMBLY/ASSEMBLY**

**[3] -1A. Chuck Section (Model HR3210FCT)**

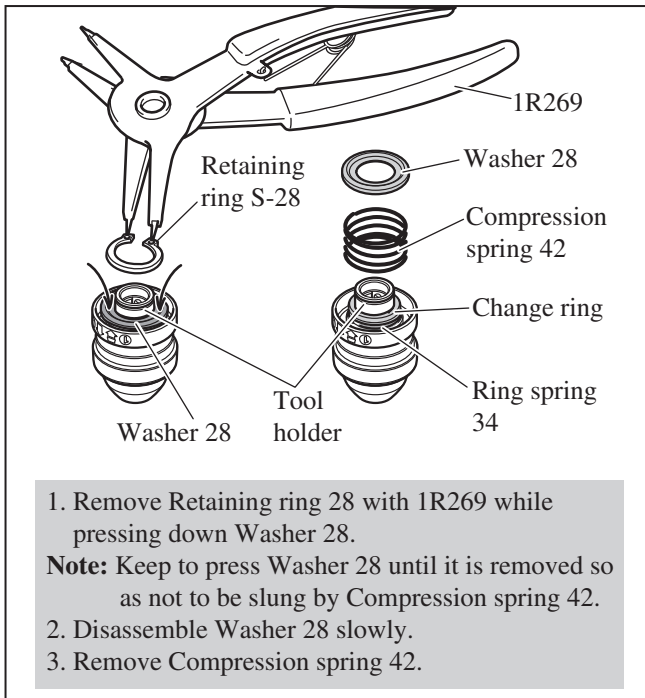
**DISASSEMBLY**

2) The construction of Tool holder assembly is as illustrated in **Fig. 8**. The rear parts can be disassembled as illustrated in **Figs. 9 and 10**. And disassemble the front Parts as illustrated in **Fig. 11**.

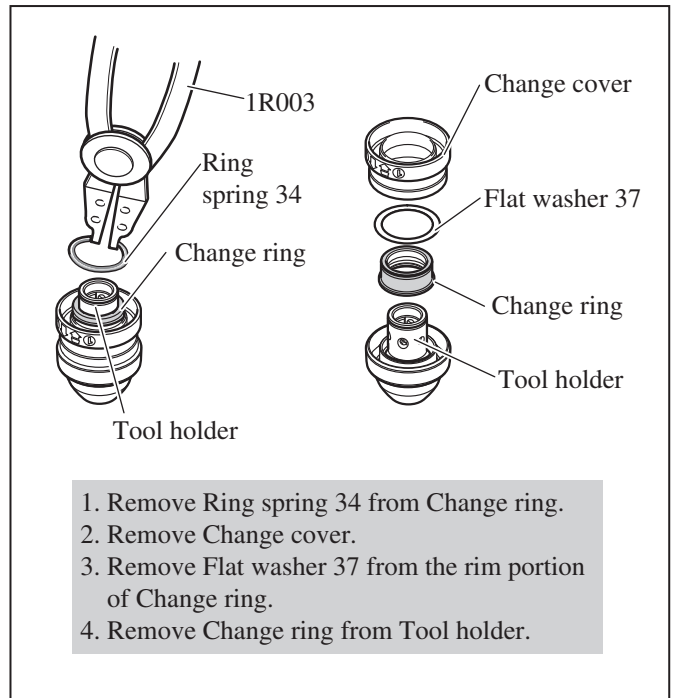
**Fig. 8**



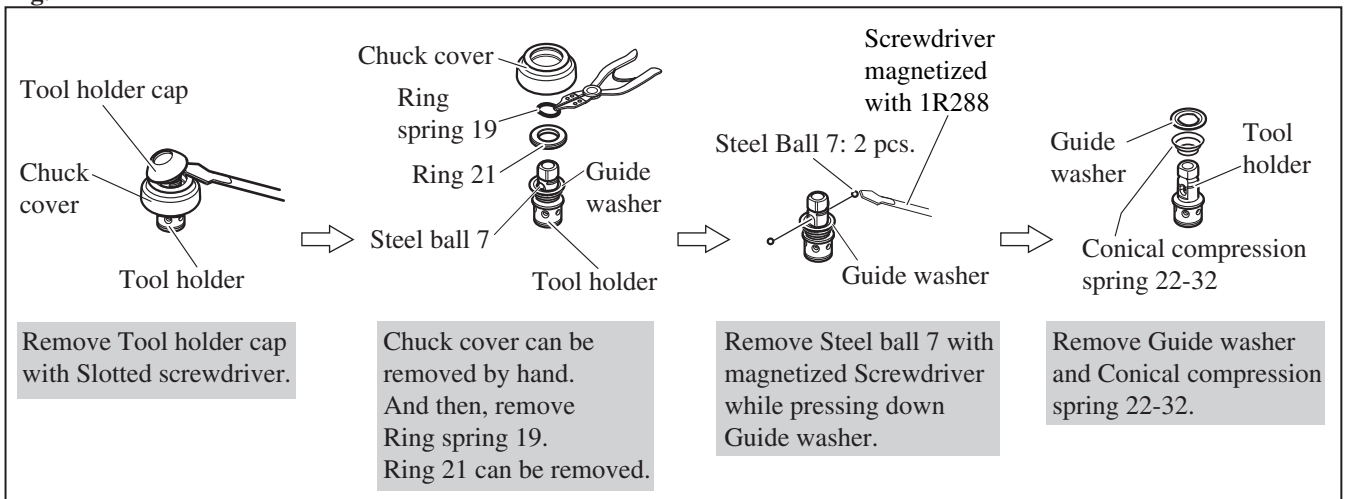
**Fig. 9**



**Fig. 10**



**Fig. 11**



## ► Repair

### [3] DISASSEMBLY/ASSEMBLY

#### [3] -1. Chuck Section (Model HR3200, HR3210C)

##### ASSEMBLY

Take the reverse steps of the disassembling procedure.  
Refer to **Figs. 6 and 5.**

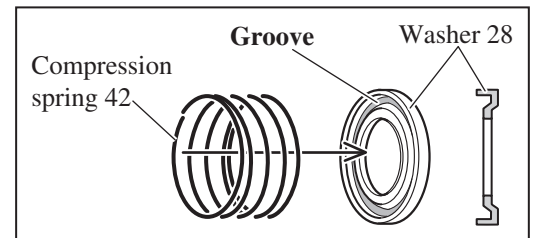
#### [3] -1A. Chuck Section (Model HR3210FCT)

##### ASSEMBLY

Take the reverse steps of the disassembling procedure.  
Refer to **Figs. 11, 10, 9 and 7.**

**Note:** Fit Compression spring 42 into the groove of Washer 28. (**Fig. 12**)

**Fig. 12**

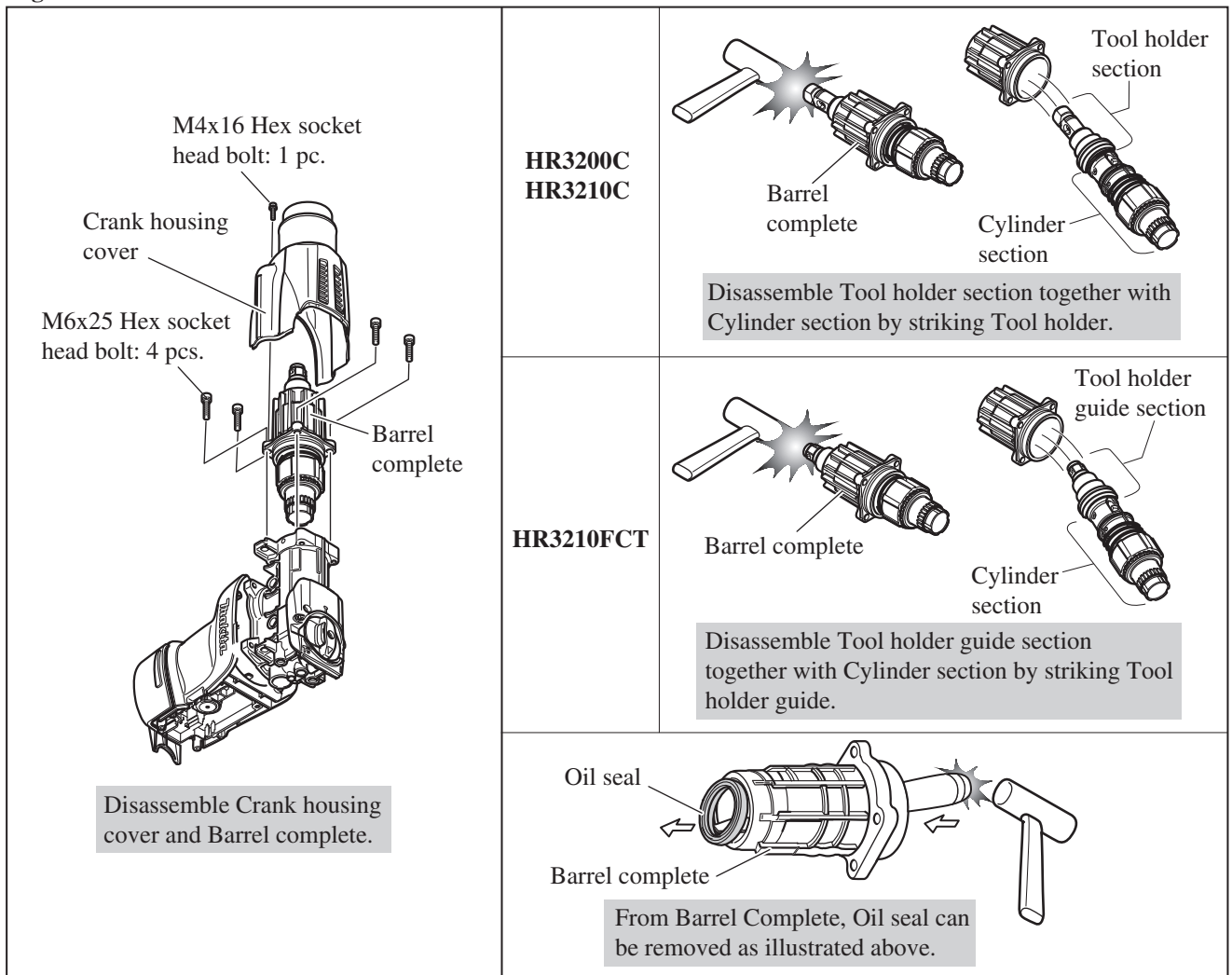


#### [3] -2. Tool Holder Section

##### DISASSEMBLY

- 1) Disassemble Chuck section as illustrated in **Figs. 5 and 6.** (Model HR3200C, HR3210C)
- 1A) Separate Tool holder assembly from the Machine as illustrated in **Figs 5 and 7.** (HR3210FCT)
- 2) Disassemble Tool holder section (HR3210FCT: Tool holder guide section) together with Cylinder section.  
And Oil seal can be removed from Barrel complete as illustrated in **Fig. 13.**

**Fig. 13**



► **Repair**

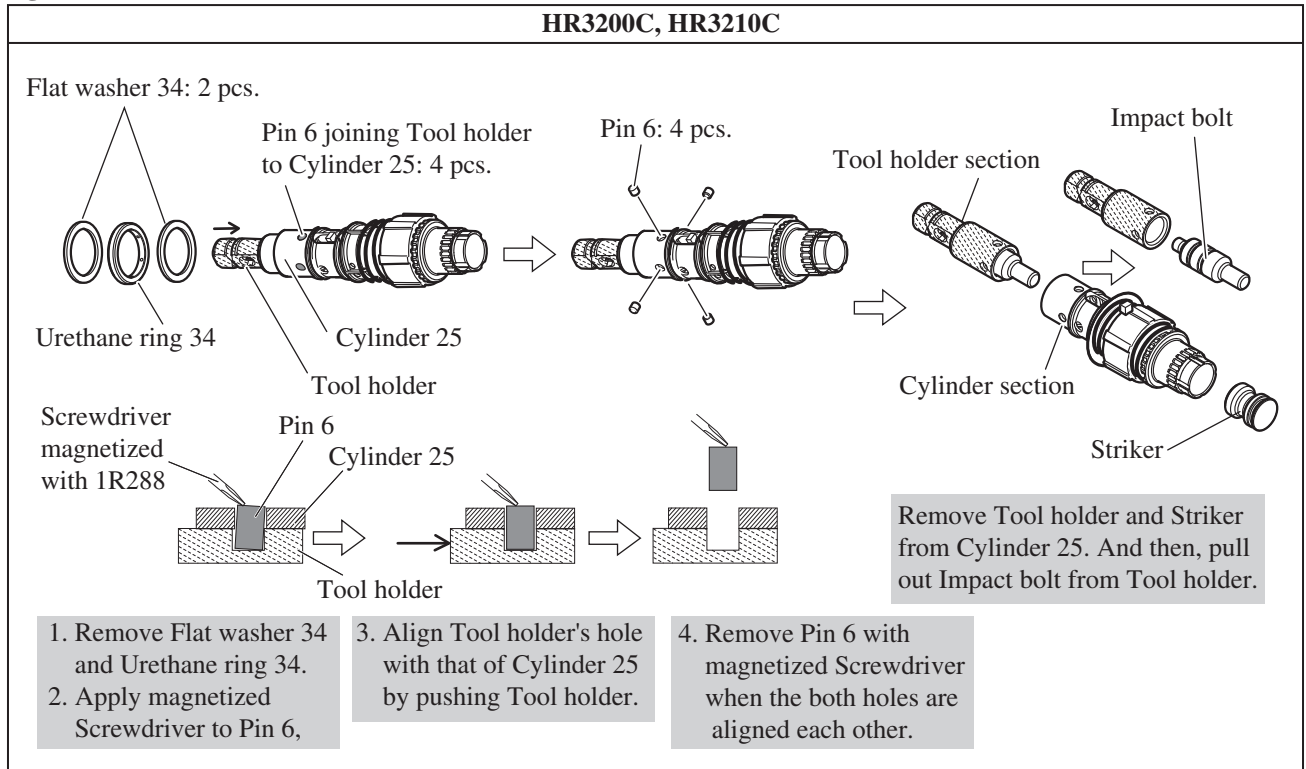
**[3] DISASSEMBLY/ASSEMBLY**

**[3] -2. Tool Holder Section**

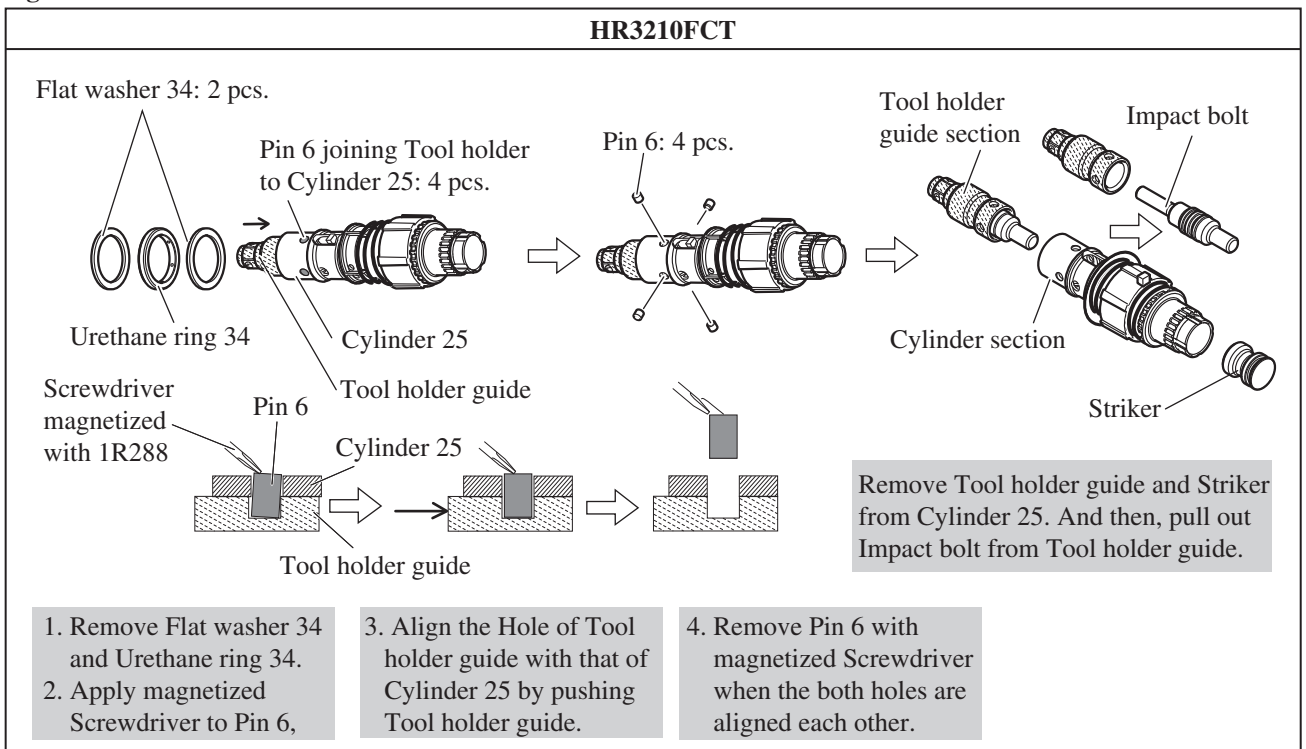
**DISASSEMBLY**

- 3) HR3200C, HR3210C: Separate Tool holder section from Cylinder section, and remove Impact bolt from Tool holder. **(Fig. 14)** Now Rings on Impact bolt are ready to be replaced in the next step.
- 3A) HR3210FCT: Separate Tool holder guide section from Cylinder section, and remove Impact bolt from Tool holder guide. **(Fig. 14A)** Now Rings on Impact bolt are ready to be replaced in the next step.
- 4) If Dust is recognized inside Tool holder (Tool holder guide) after removing Impact bolt, make the inside clean.

**Fig. 14**



**Fig. 14A**





► **Repair**

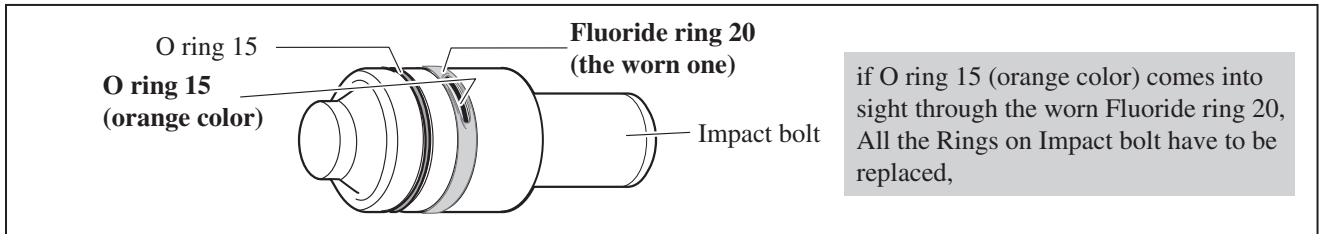
**[3] DISASSEMBLY/ASSEMBLY**

**[3] -2. Tool holder section**

**DISASSEMBLY**

5) If Fluoride ring 20 is in the condition as illustrated in **Fig. 15**, all the Rings on Impact bolt have to be replaced.

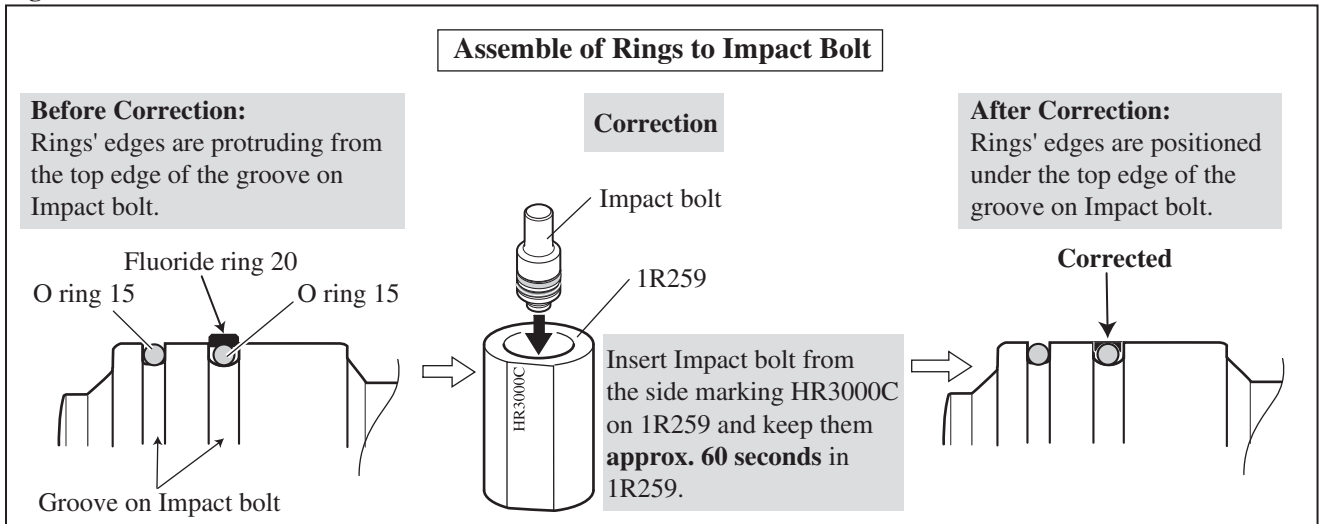
**Fig. 15**



**ASSEMBLY**

1) Replace Rings on Impact bolt as illustrated in **Fig. 16**.

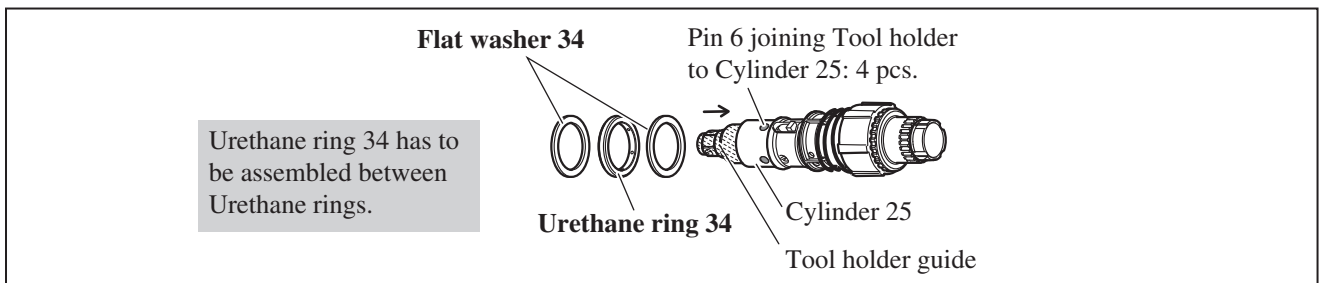
**Fig. 16**



2) Take the reverse of the disassembling steps. Refer to **Figs. 14 (or 14A) and 13**.

**Note:** Flat washers and Urethane ring have to be assembled to Cylinder 25 to fix Pin 6 as illustrated in **Fig. 17**.

**Fig. 17**



► **Repair**

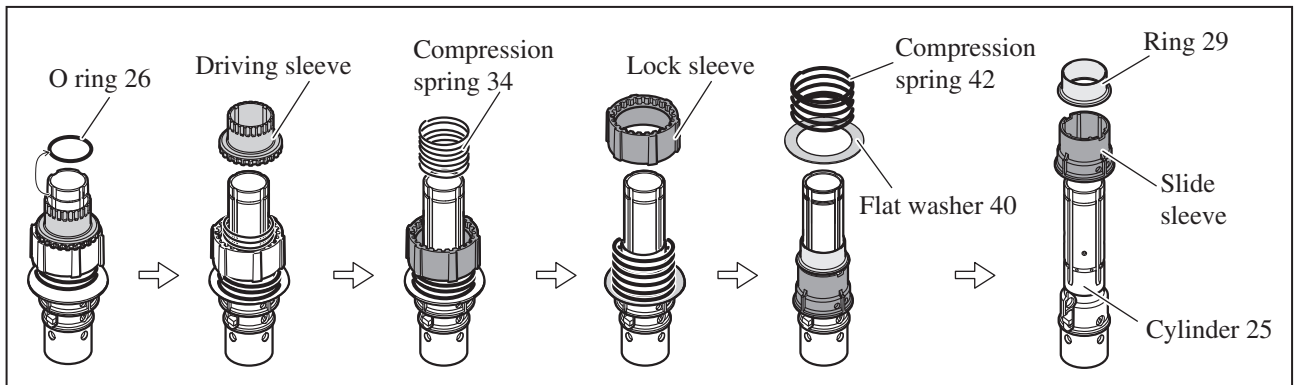
**[3] DISASSEMBLY/ASSEMBLY**

**[3] -3. Cylinder Section**

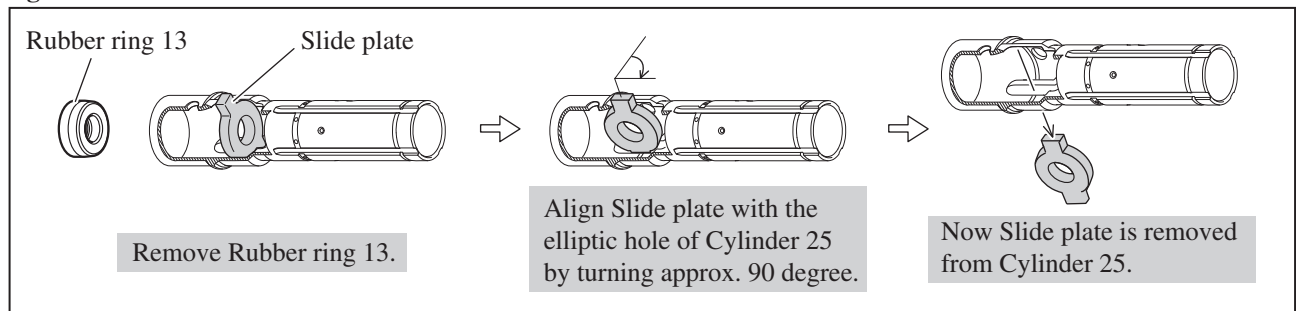
**DISASSEMBLY**

- 1) HR3200C, HR3210C: Disassemble Chuck section. (**Figs. 5 and 6**)  
HR3210FCT: Disassemble Tool holder assembly. (**Figs. 5 and 7**)
- 2) After removing Crank housing cover, disassemble Barrel complete, and separate Tool holder section from Barrel complete. (**Fig. 13**)
- 3) Separate Tool holder section (Tool holder guide section) from Cylinder section. (**Figs. 14 and 14A**)
- 4) The parts on Cylinder 25 can be removed as illustrated in **Fig. 18**.
- 5) Disassemble Rubber ring 13 and Slide plate from the inside of Cylinder 25 as illustrated in **Fig. 19**.

**Fig. 18**



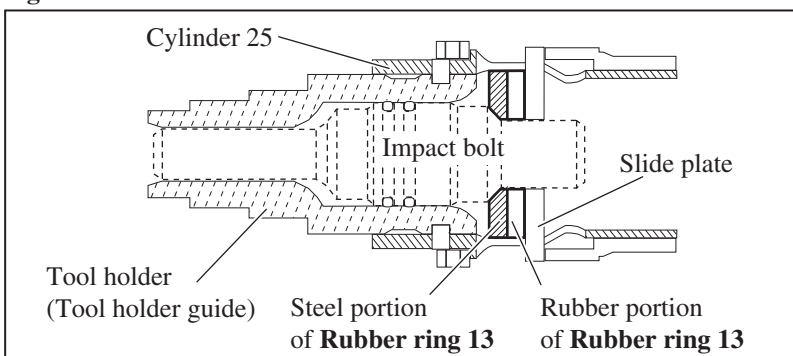
**Fig. 19**



**ASSEMBLY**

- 1) Take the reverse of the disassembling steps. Refer to **Figs. 19 and 18**.  
Join the assembled Cylinder section to Tool holder (Tool holder guide section) with Pin 6.  
Refer to **Figs. 14 and 14A**.
- Note:** When inserting Rubber ring 13 into Cylinder 25, face the steel portion of Rubber ring 13 to Tool holder (Tool holder guide) side as illustrated in **Fig. 19**.

**Fig. 20**



► **Repair**

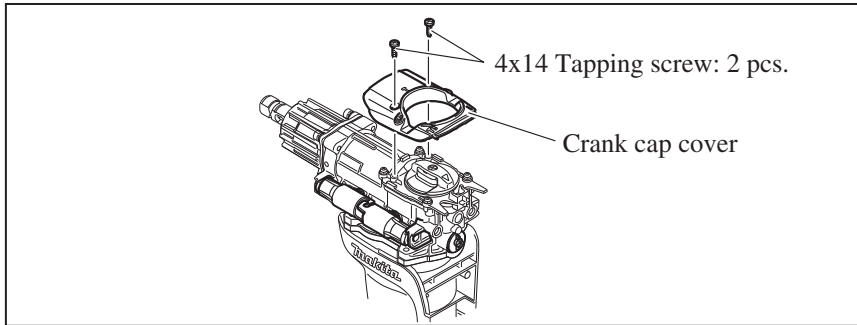
**[3] DISASSEMBLY/ASSEMBLY**

**[3] -4. Active Dynamic Vibration Absorber**

**DISASSEMBLY**

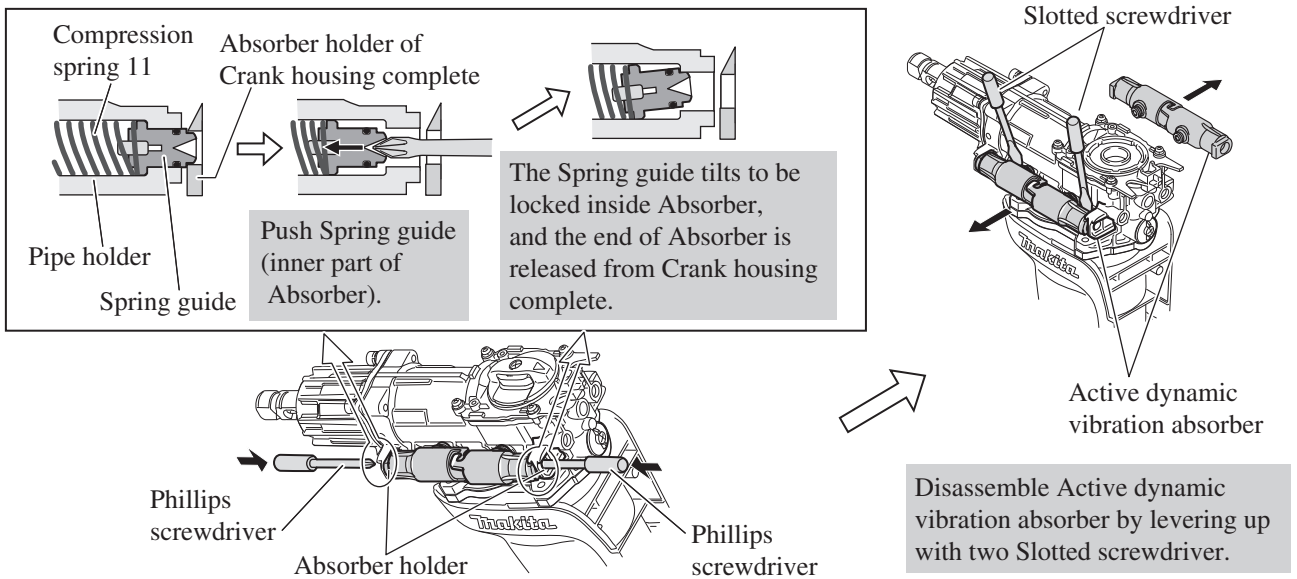
- 1) Disassemble Handle section. (Fig. 5)
- 2) HR3200C, HR3210FC: Disassemble Chuck section. (Fig. 6)
- 2A) HR3210FCT: Disassemble Tool holder assembly. (Fig. 7)
- 3) Disassemble Crank housing cover. (Fig. 13) And remove Crank cap cover as illustrated in Fig. 21.
- 4) Remove Active Dynamic Vibration Absorber from Crank housing complete as illustrated in Fig. 22. And disassemble as illustrated in Fig. 23.

**Fig. 21**

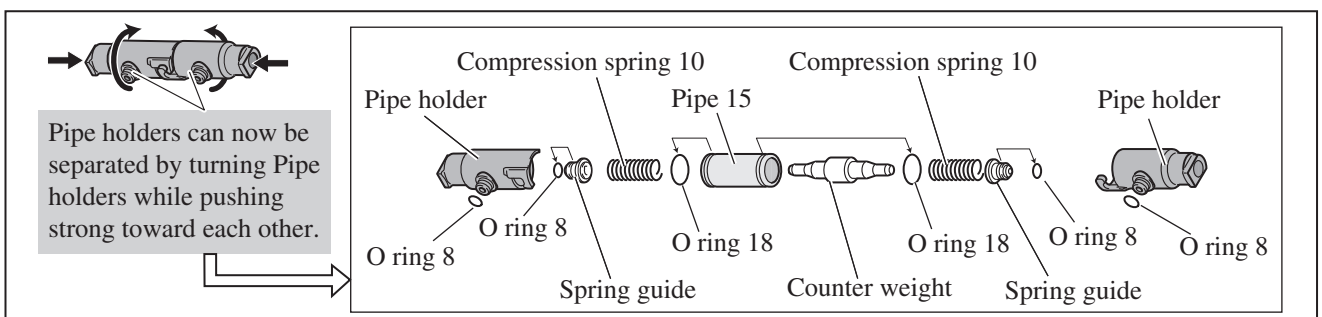


**Fig. 22**

Disassemble Active Dynamic Vibration Absorber as follows.



**Fig. 23**



## ► Repair

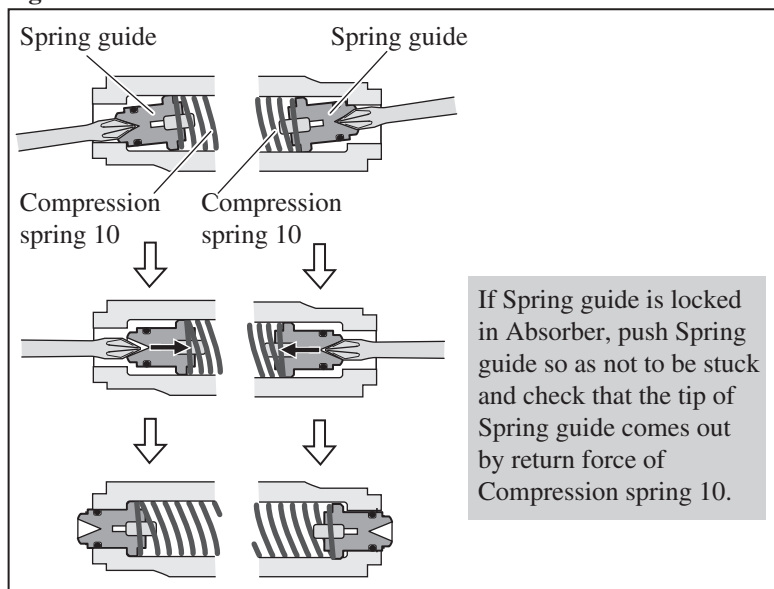
### [3] DISASSEMBLY/ASSEMBLY

#### [3] -4. Active Dynamic Vibration Absorber

##### ASSEMBLY

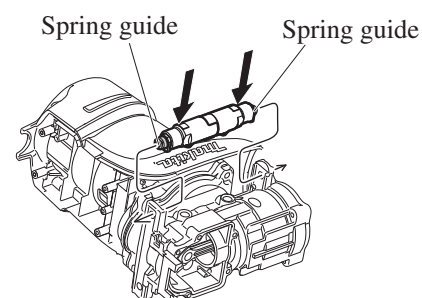
- 1) Assemble Active dynamic vibration absorber. Refer to **Fig. 23**.
- 2) Set Spring guide to the position in place as illustrated in **Fig. 24**.
- 3) Mount the Active dynamic vibration absorber on the both side of Crank housing complete. (**Fig. 25**)
- 4) After the step of **Fig. 25**, take the reverse of disassembling. Refer to **Figs 21, 13, 7 or 6 and Fig. 5**.

**Fig. 24**



**Fig. 25**

Assemble Active dynamic vibration absorber by pressing while maintaining the position parallel to Crank housing.

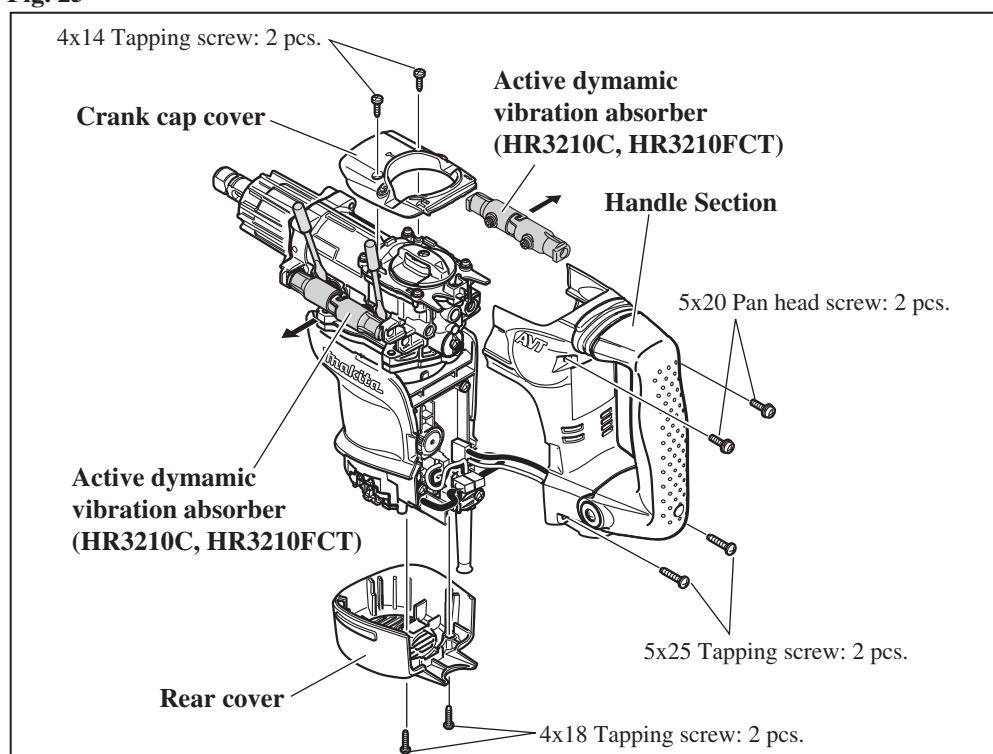


#### [3] -5. Motor Section, Torque Limiter Section

##### DISASSEMBLY

- 1) HR3200C, HR3210C: Disassemble Chuck section. (**Fig. 6**)  
HR3210FCT: Remove Tool holder assembly. (**Fig. 7**)
- 2) Remove Crank housing cover. (**Fig. 13**)
- 3) As illustrated in **Fig. 25**, disassemble Crank cap cover, Active dynamic vibration absorber, Handle section and Rear cover from Crank housing complete and Motor housing.

**Fig. 25**



► **Repair**

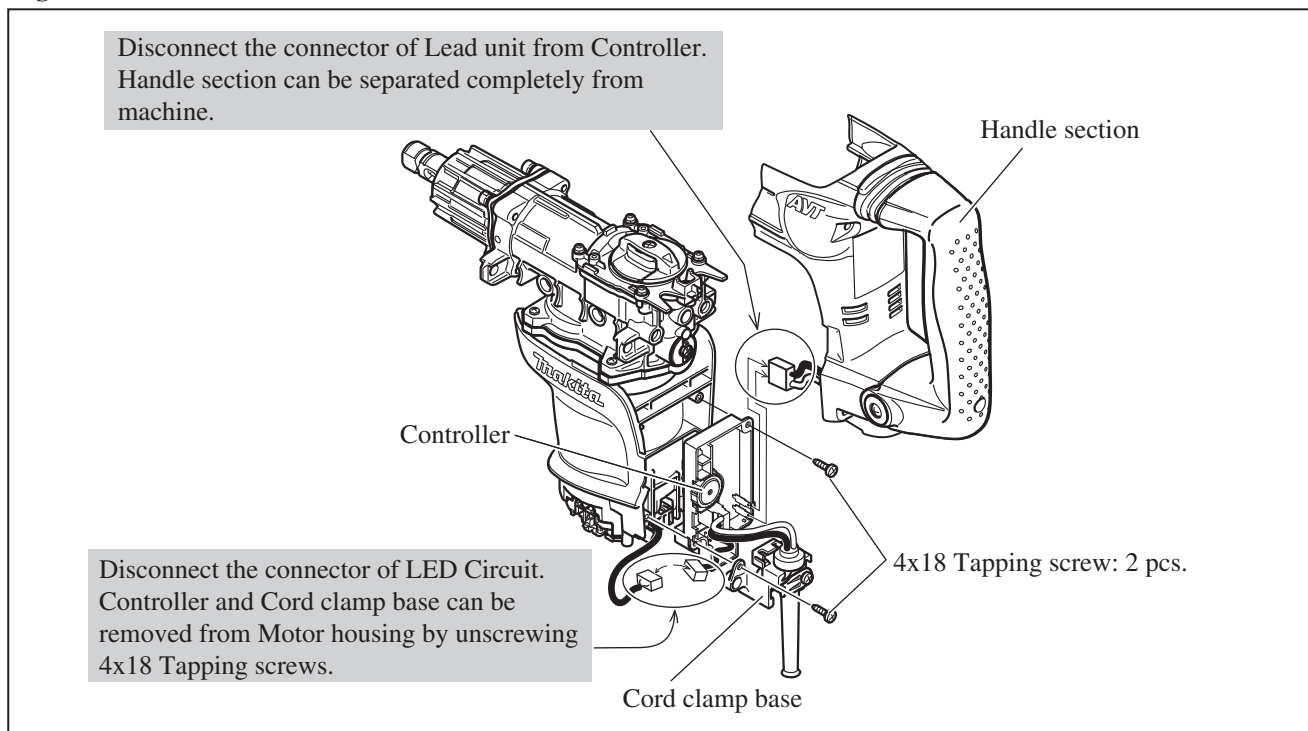
**[3] DISASSEMBLY/ASSEMBLY**

**[3] -5. Motor Section, Torque Limiter Section**

**DISASSEMBLY**

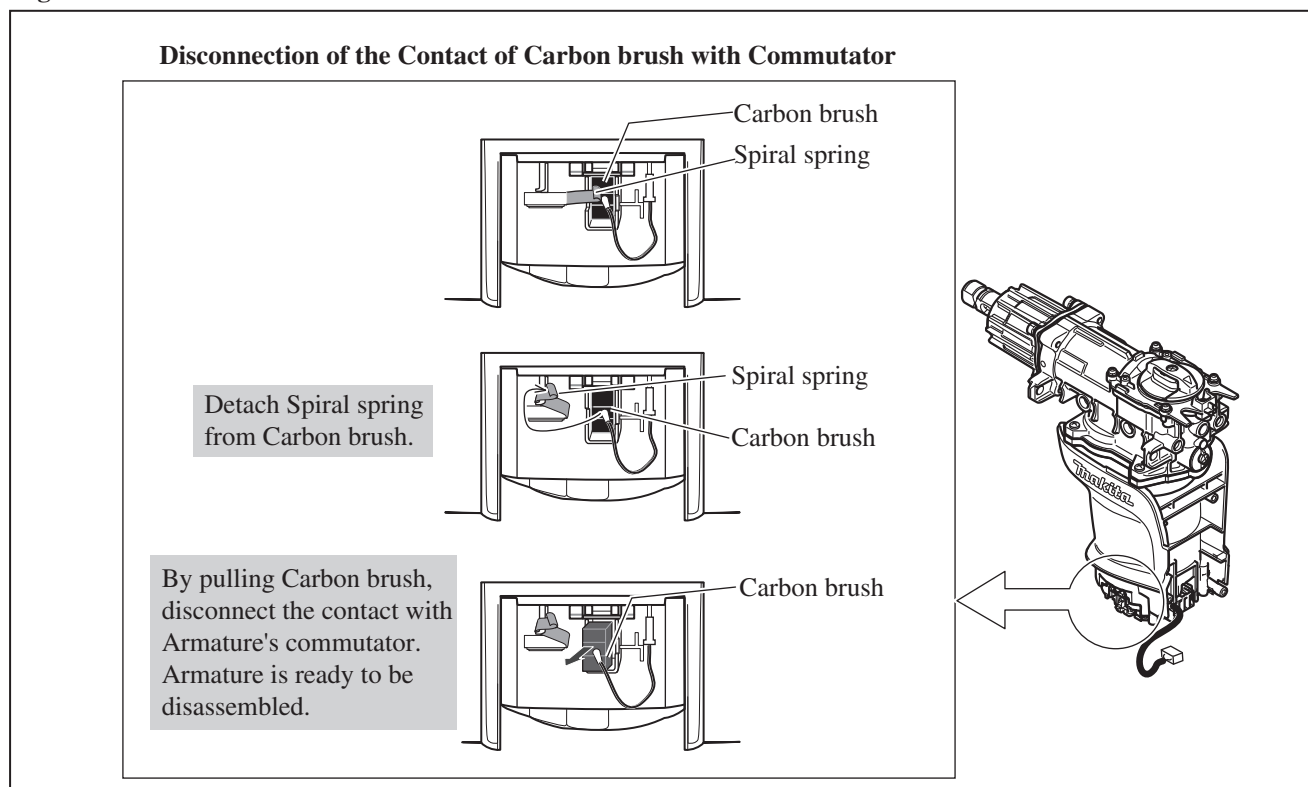
4) Disconnect connectors to disassemble Handle section as illustrated in **Fig. 26**.

**Fig. 26**



5) Disconnect the contact between Carbon brush and Commutator as illustrated in **Fig. 27**.

**Fig. 27**



► **Repair**

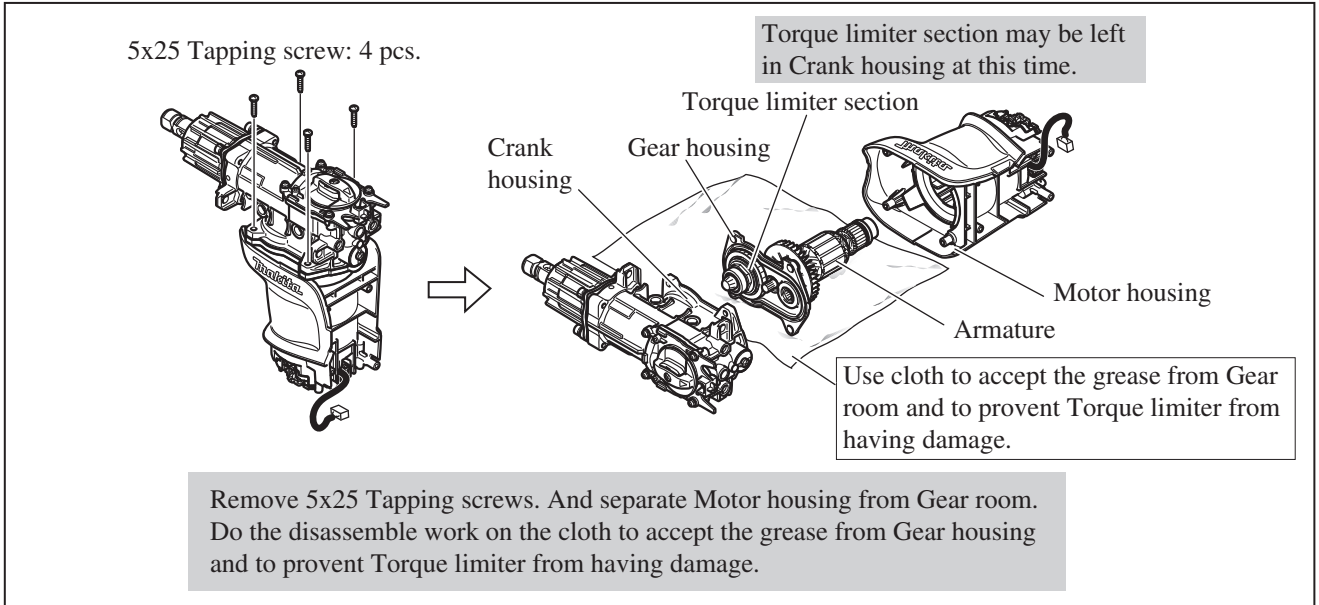
**[3] DISASSEMBLY/ASSEMBLY**

**[3] -5. Motor Section, Torque Limiter Section**

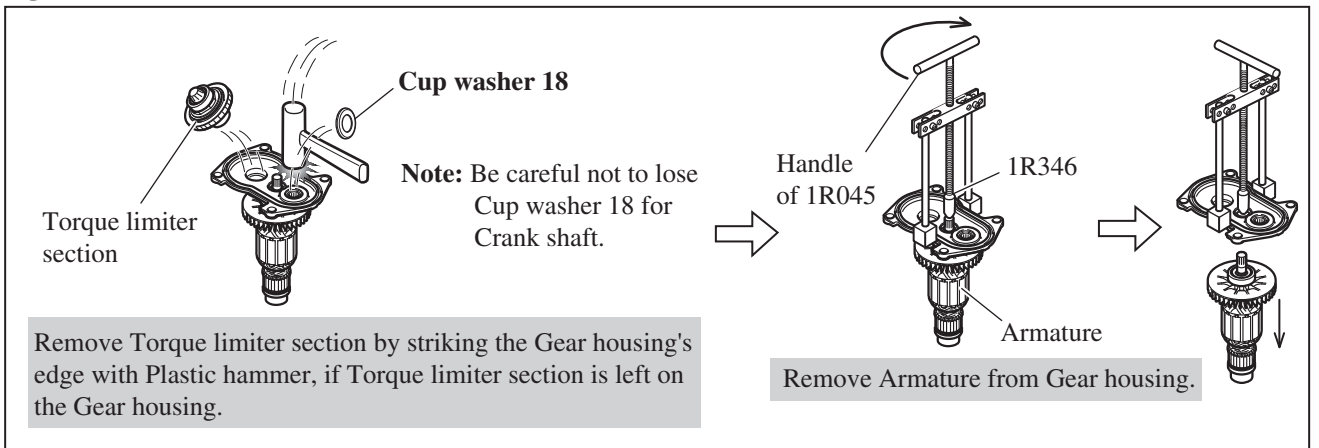
**DISASSEMBLY**

6) Disassemble Armature as illustrated in **Figs. 28 and 29**.

**Fig. 28**

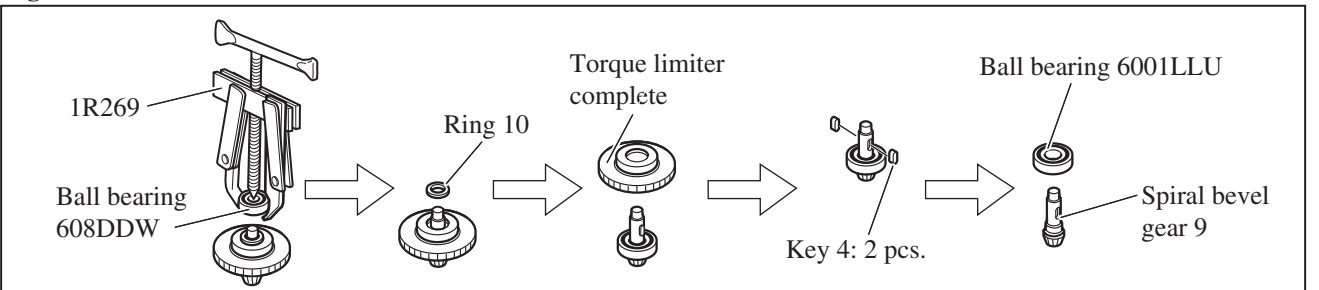


**Fig. 29**



7) Torque limiter section can be disassembled as illustrated in **Fig. 30**.

**Fig. 30**



**ASSEMBLY**

Take the reverse step of the disassembling procedure. Refer to **Figs. 30 to 25**.

► **Repair**

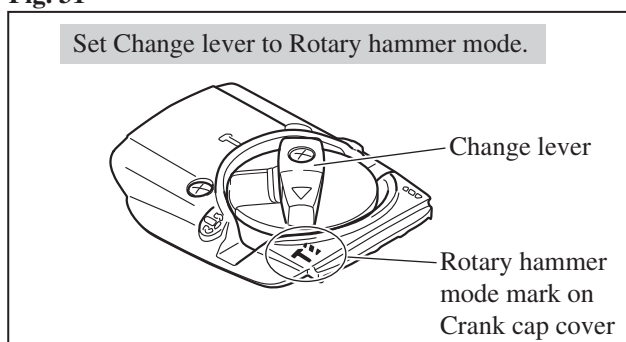
**[3] DISASSEMBLY/ASSEMBLY**

**[3] -6. Gear Section in Crank Housing Complete**

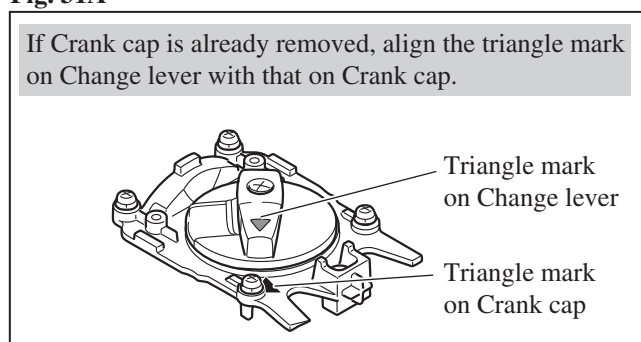
**DISASSEMBLY**

- 1) Disassemble Handle Section (Fig. 5)
- 2) HR3200C, HR3210C: Disassemble Chuck Section (Fig. 6)  
HR3210FCT: Disassemble Tool holder assembly. (Fig. 7)
- 3) Remove Crank housing cover and Barrel complete together with Cylinder section. (left illustration in Fig. 13)
- 4) Set Change lever to Rotary hammer mode as illustrated in Fig. 31. Remove Crank cap cover. (Fig. 21)
- 5) HR3210C, HR3210FCT: Disassemble Active Dynamic Vibration Absorber. (Fig. 22)
- 6) Disassemble Rear cover from Motor housing. (Fig. 25)
- 7) Disconnect the contact between Carbon brush and Commutator. (Fig. 27)
- 8) Separate Crank housing complete from Motor housing. (Fig. 28)
- 9) If it is omitted to set Change lever to Rotary Hammer Mode when removing Crank cap cover, set Change lever as illustrated in Fig. 31A.
- 10) Disassemble the remaining parts as illustrated in Figs 32 and 33.

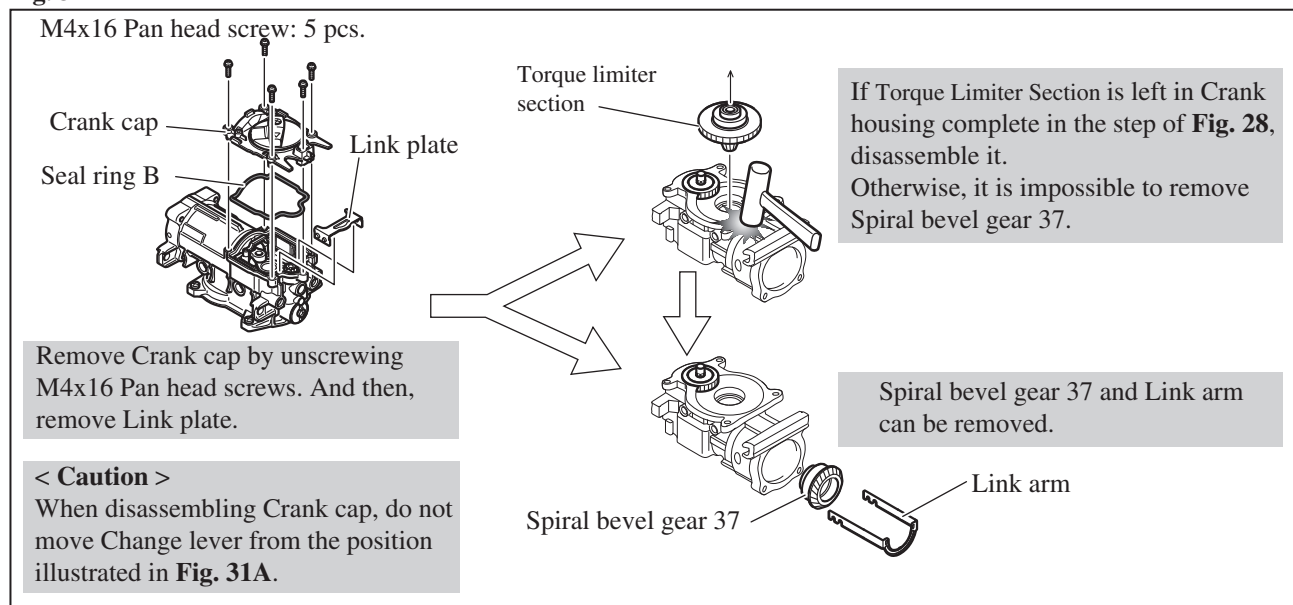
**Fig. 31**



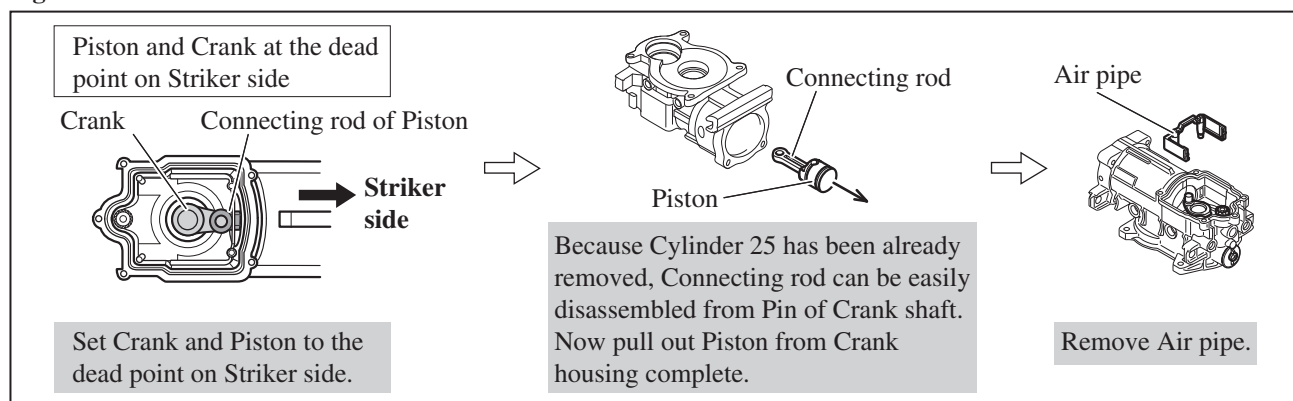
**Fig. 31A**



**Fig. 32**



**Fig. 33**



► **Repair**

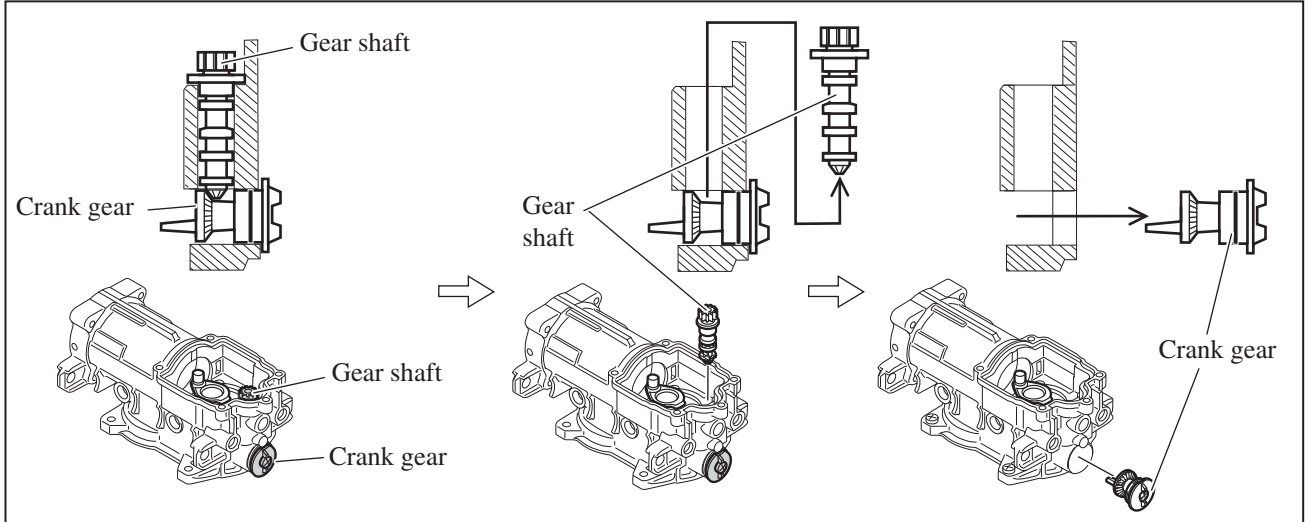
**[3] DISASSEMBLY/ASSEMBLY**

**[3] -6. Gear Section in Crank Housing Complete**

**DISASSEMBLY**

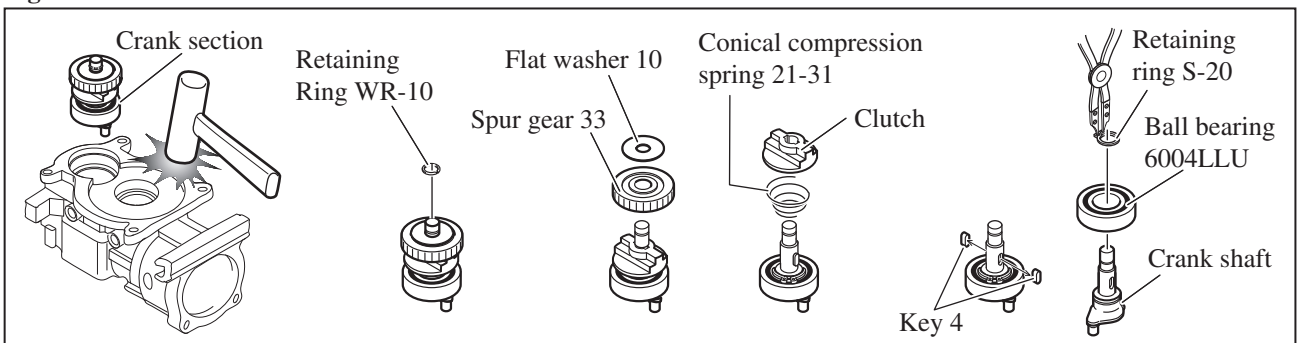
11) Gear unit for Changing operation mode is still left in Crank housing complete.  
Disassemble in order of Gear shaft and Crank gear as illustrated in **Fig. 34**.

**Fig. 34**



12) Crank Section can be disassembled as illustrated in **Fig. 35**.

**Fig. 35**





► **Repair**

**[3] DISASSEMBLY/ASSEMBLY**

**[3] -6. Gear Section in Crank Housing Complete**

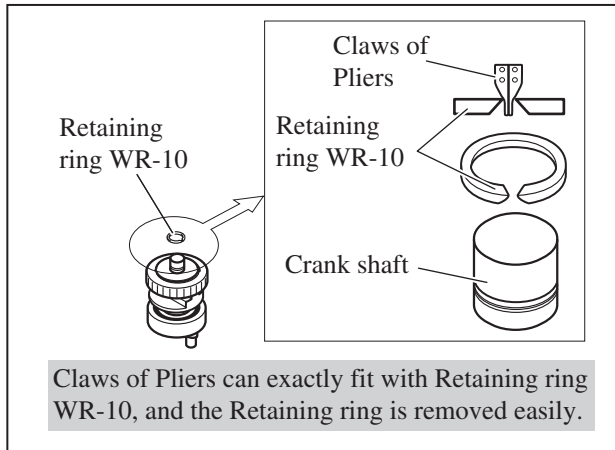
**ASSEMBLY**

- 1) Assemble Crank section by taking the reverse of Disassembling steps. Refer to **Fig. 35**.  
And then, mount the Crank section to Crank housing complete.

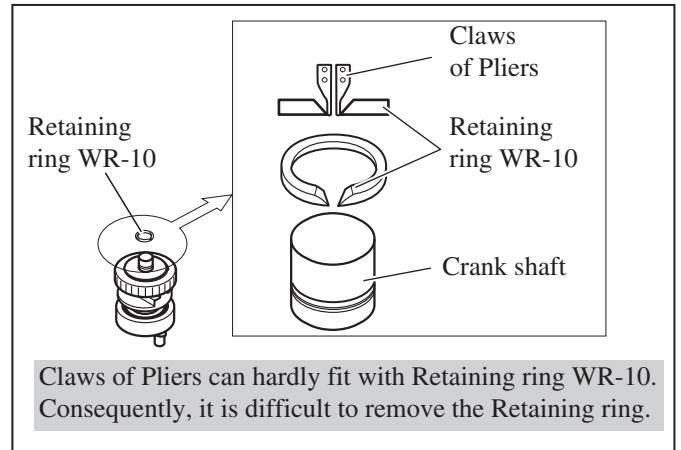
**Note:** When assembling Retaining ring WR-10 to Crank shaft, assemble it as illustrated in **Fig. 36R**.

- 2) Assemble Gears for changing operation mode as illustrated in **Fig. 37**.

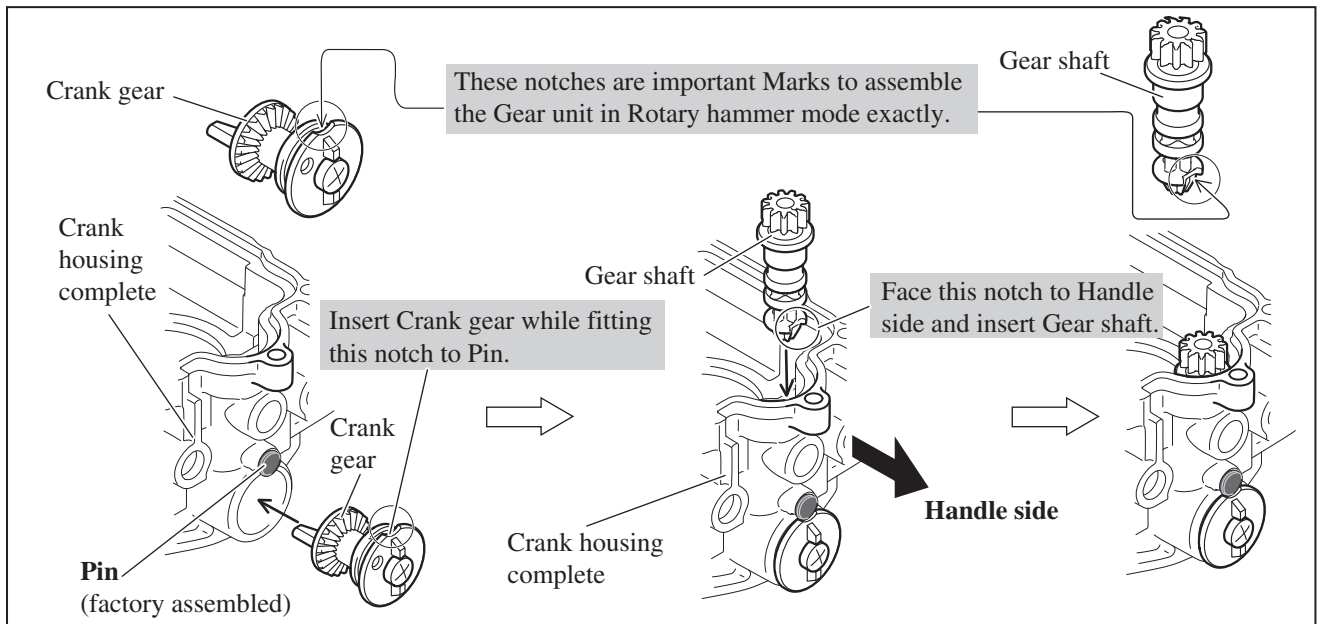
**Fig. 36R**



**Fig. 36F**



**Fig. 37**



## ► Repair

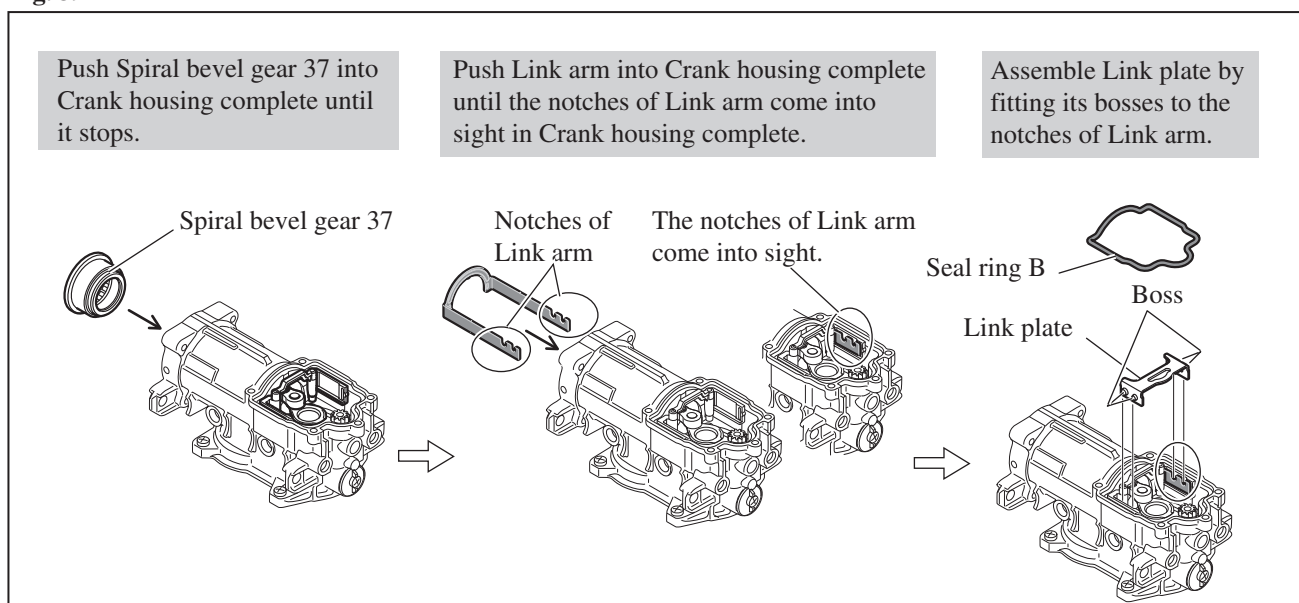
### [3] DISASSEMBLY/ASSEMBLY

#### [3] -6. Gear Section in Crank Housing Complete

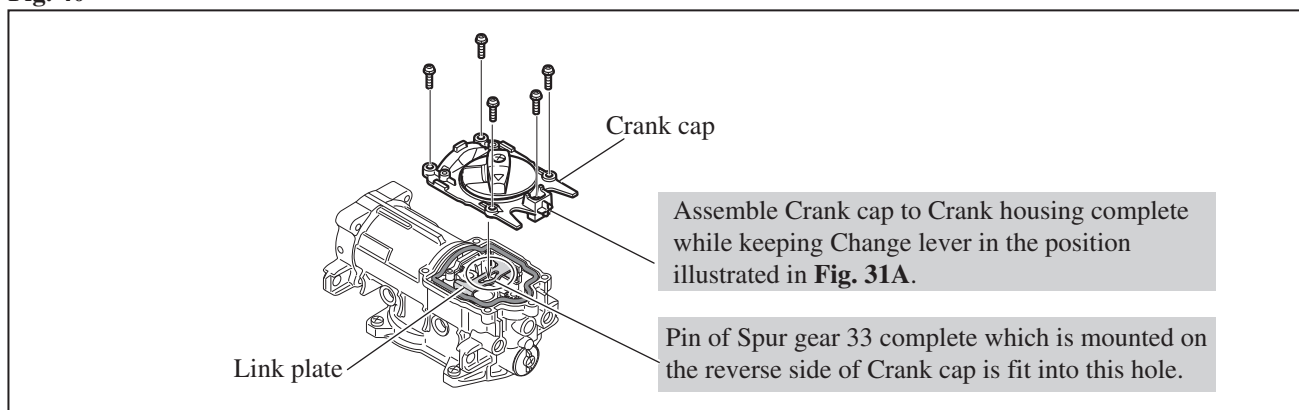
##### ASSEMBLY

- 3) Assemble Spiral bevel gear 37, Link arm, Seal ring B and Link plate as illustrated in **Fig. 39**.
- 4) Assemble Crank cap as illustrated in **Fig. 40**.
- 5) Assemble Crank cap cover. The triangle mark on Change lever has to designate the mark of Rotary hammer mode on Crank cap cover as illustrated in **Fig. 31**.

**Fig. 39**



**Fig. 40**



- 6) Assemble the remaining parts by taking the reverse of the disassembling steps.

► **Repair**

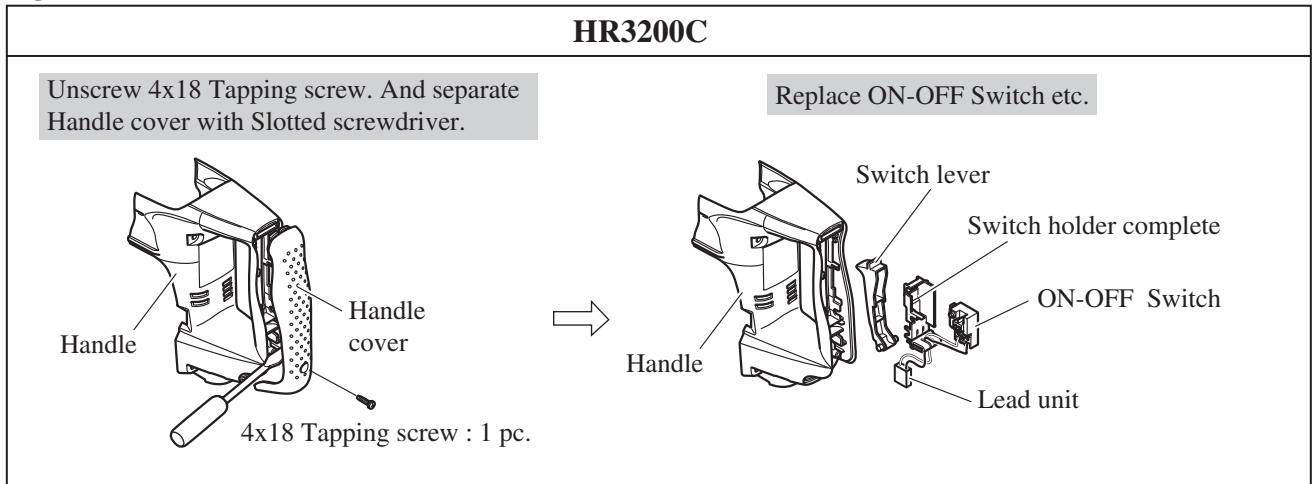
**[3] DISASSEMBLY/ASSEMBLY**

**[3] -7. Handle Section and Electrical Parts**

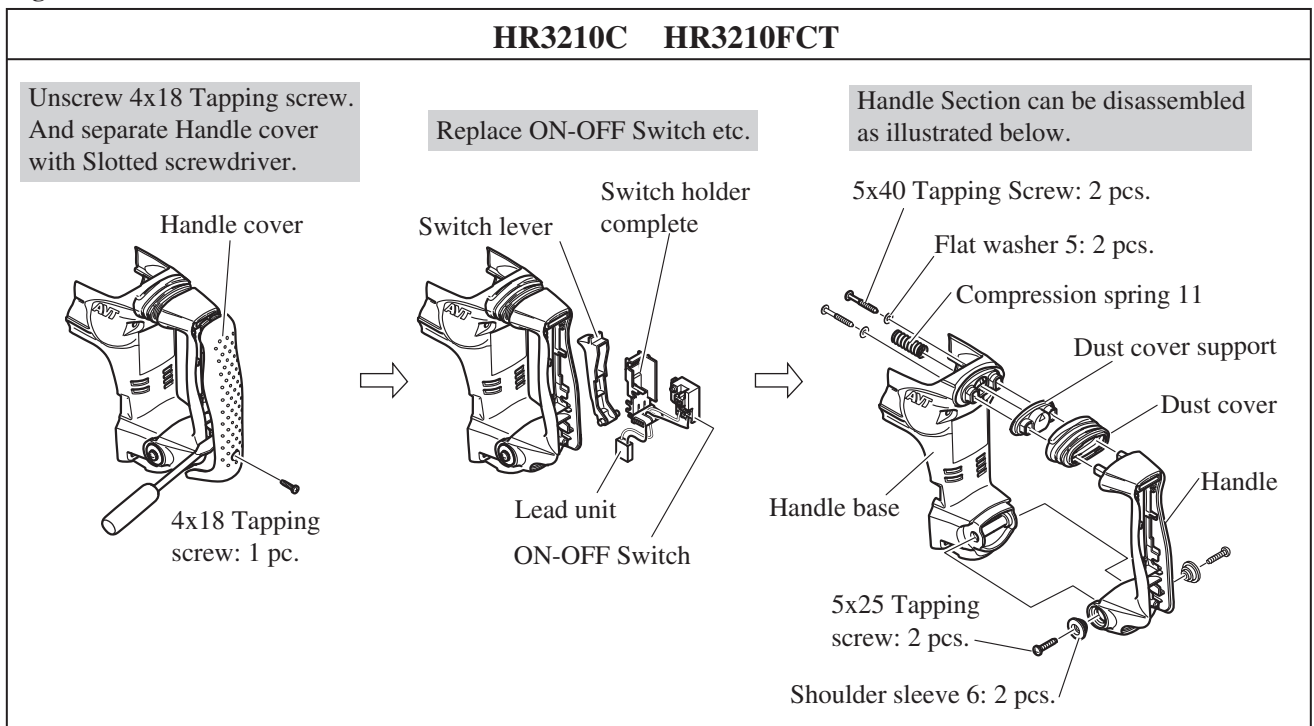
**DISASSEMBLY**

- 1) Disassemble Handle section as illustrated in **Fig. 25 and 26.**
- 2) Controller and Power supply cord can be removed. (**Fig. 26**)
- 3) HR3200C: Disassemble Handle cover. ON-OFF Switch can be replaced as illustrated in **Fig. 41.**
- 3A) HR3210C or HR3210FCT: After removing ON-OFF Switch, Handle section can be disassembled as illustrated in **Fig. 41A.**

**Fig. 41**



**Fig. 41A**



► **Repair**

**[3] DISASSEMBLY/ASSEMBLY**

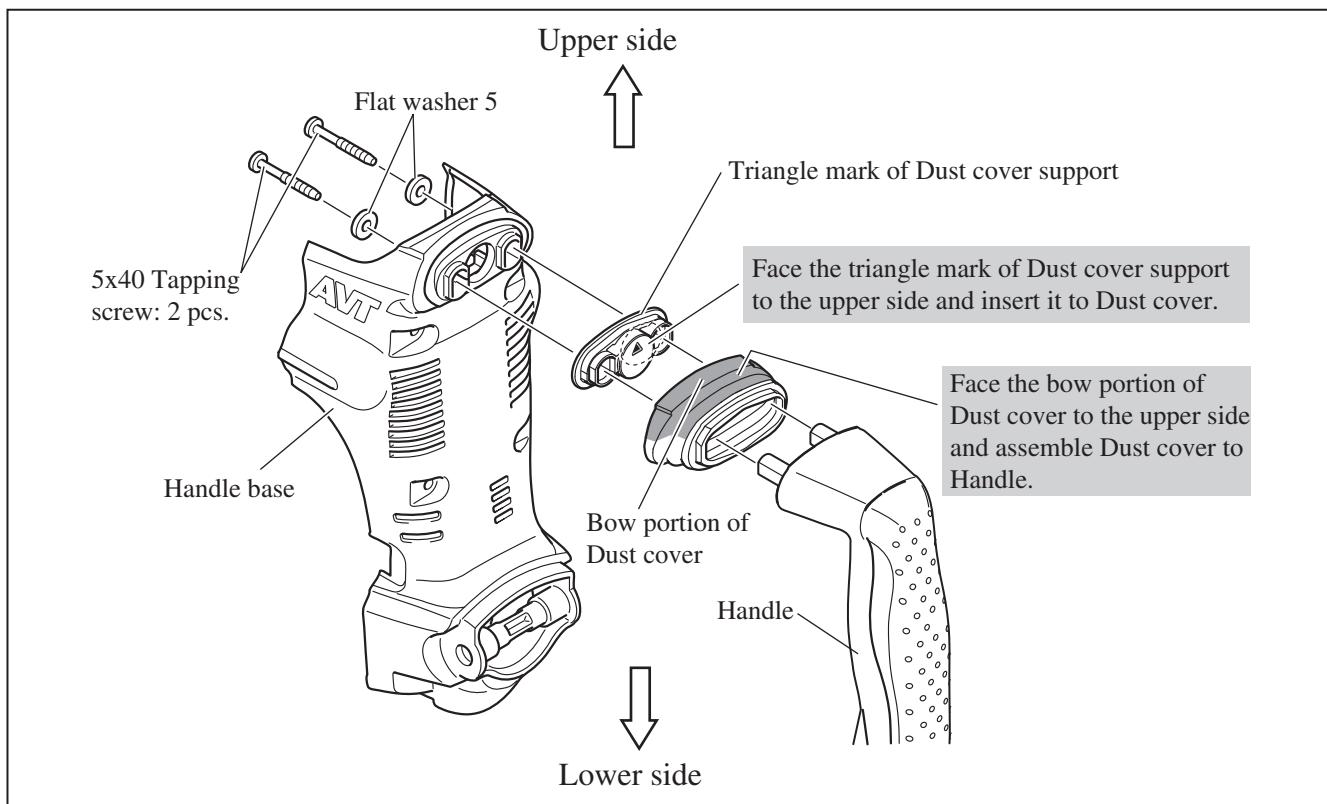
**[3] -7. Handle Section and Electrical Parts**

**ASSEMBLY**

Take the reverse of the disassembling steps.

**Note:** Dust cover support and Dust cover are directional. Refer to **Fig. 42**.

**Fig. 42**



**[3] DISASSEMBLY/ASSEMBLY**

**[3] -8. Fastening Torque of Screw and Bolt**

Fasten Bolts and Drill chuck to the specific fastening torque. Refer to **Fig. 43**.

**Fig. 43**

Item No.	Description	Q'ty	Fastening Torque
(18)	M6 x 25 Hex socket head bolt	4	<b>7.8 - 11.8 N.m</b>
(400)	Drill chuck	1	<b>34.3 - 44.1 N.m</b>

**Quick Change Drill Chuck  
(Standard Equipment for HR3210FCT)**

The diagram shows the 'Quick Change Drill Chuck' assembly. It consists of a 'Chuck holder' (labeled 400) and a 'Drill chuck' (labeled 400). The drill chuck is shown being inserted into the chuck holder.

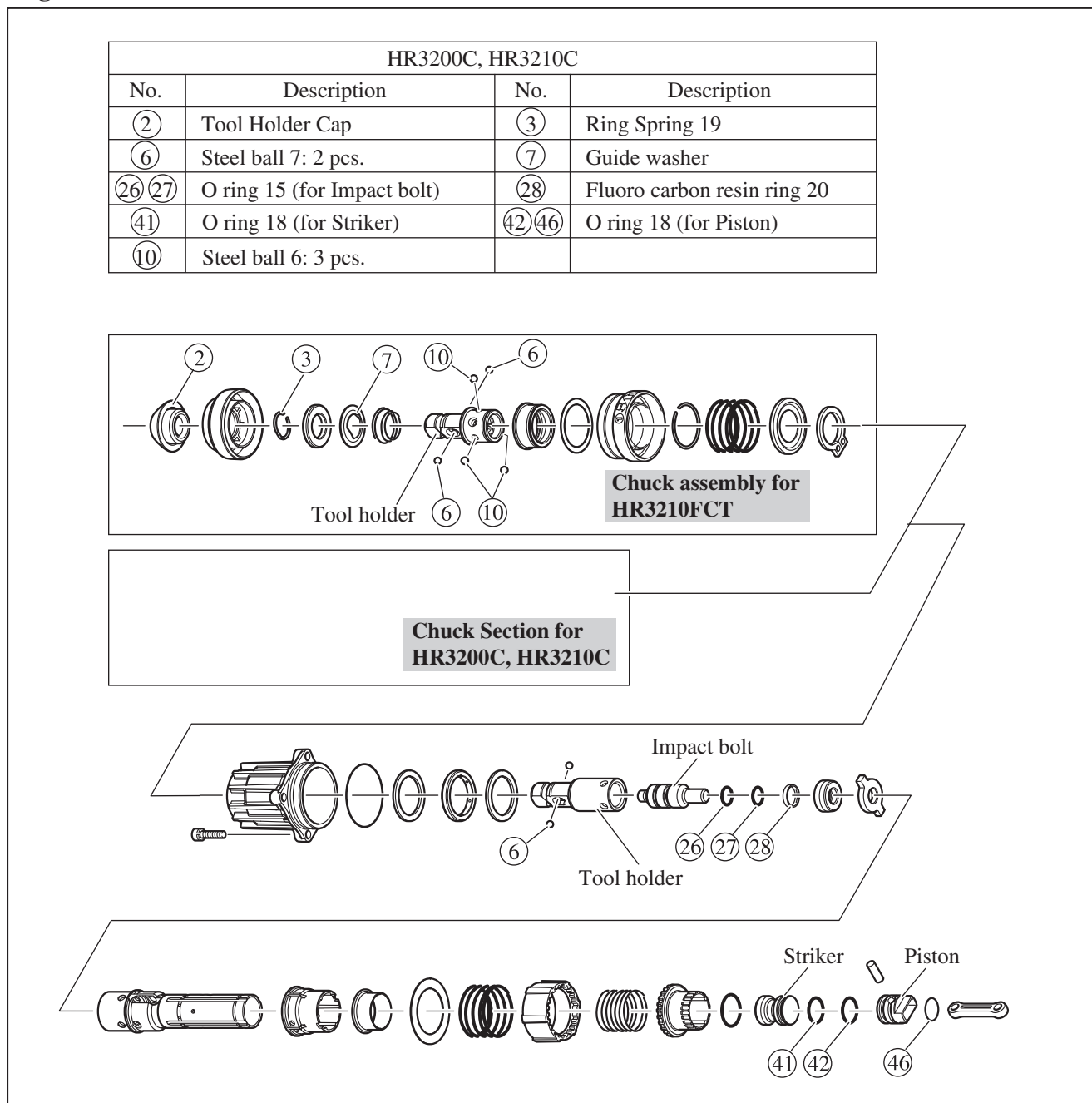
The diagram shows the 'Barrel complete' (labeled 18) being inserted into the 'Crank Housing Complete'. Four 'M6 x 25 Hex socket head bolts' (labeled 18) are used to secure the barrel to the crank housing.

► **Repair**

**[4] MAINTENANCE PROGRAM**

Replacing the following parts at the same time is recommended when replacing Carbon brushes is required. See **Fig. 44**.  
**Note:** Be sure to put Makita grease R No. 00 and N No. 2 to the specific portions. Refer to **pages 2 and 3**.

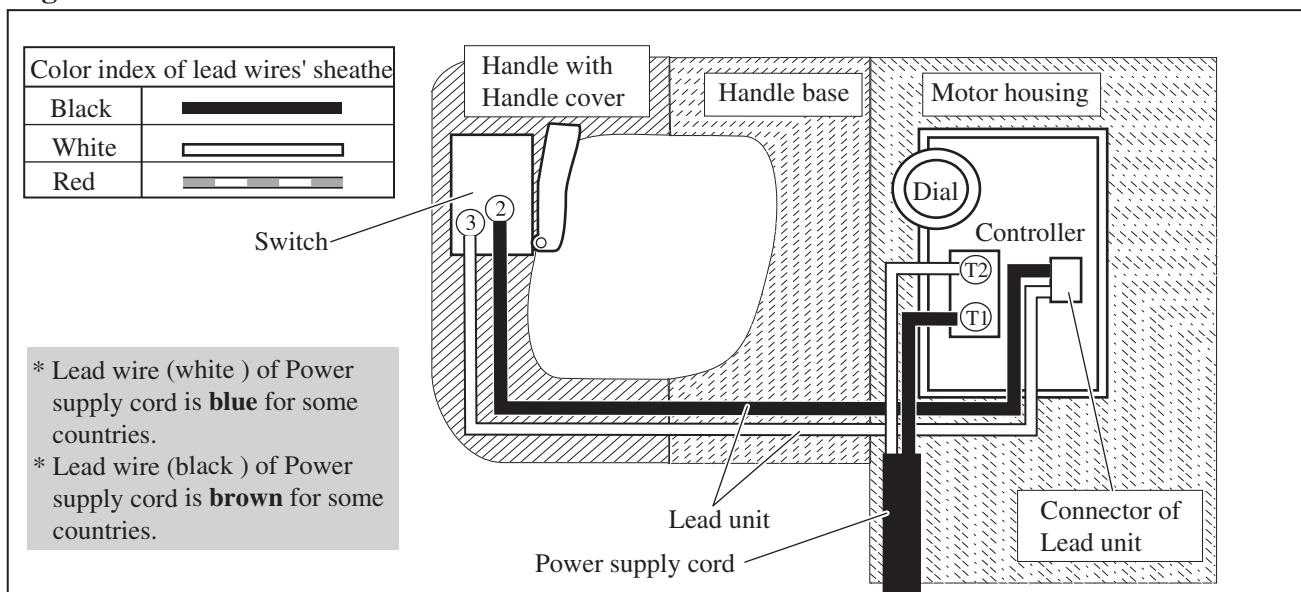
**Fig. 44**



► **Circuit diagram**

HR3200C, HR3210C

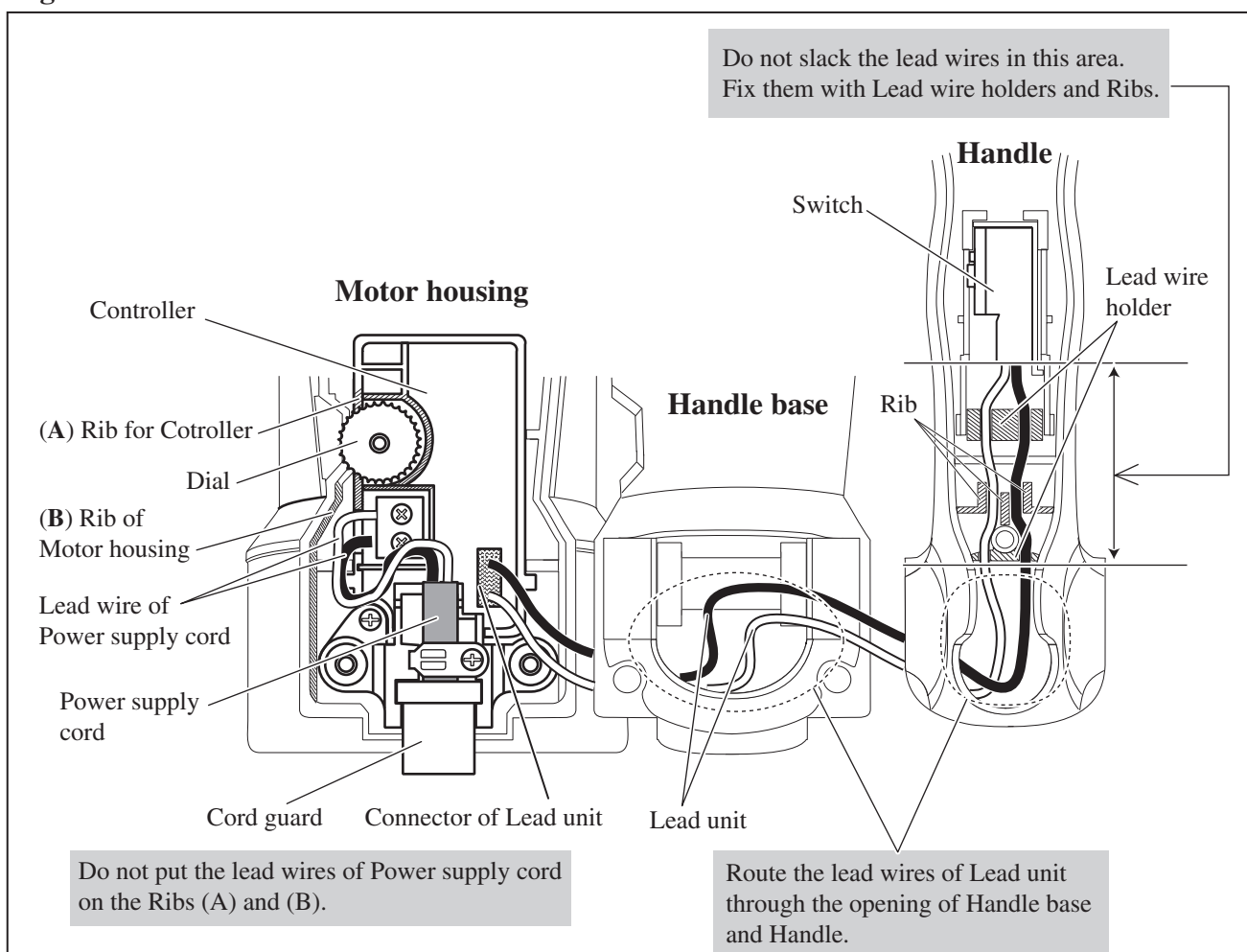
Fig. D-1



► **Wiring diagram**

HR3200C, HR3210C

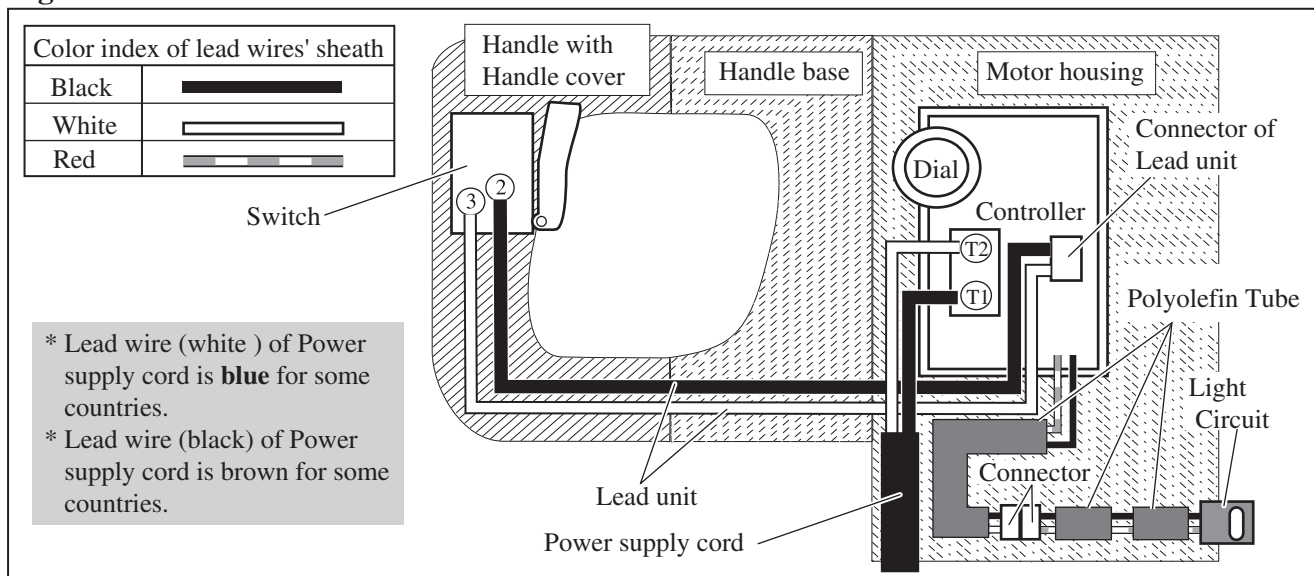
Fig. D-2



► **Circuit diagram**

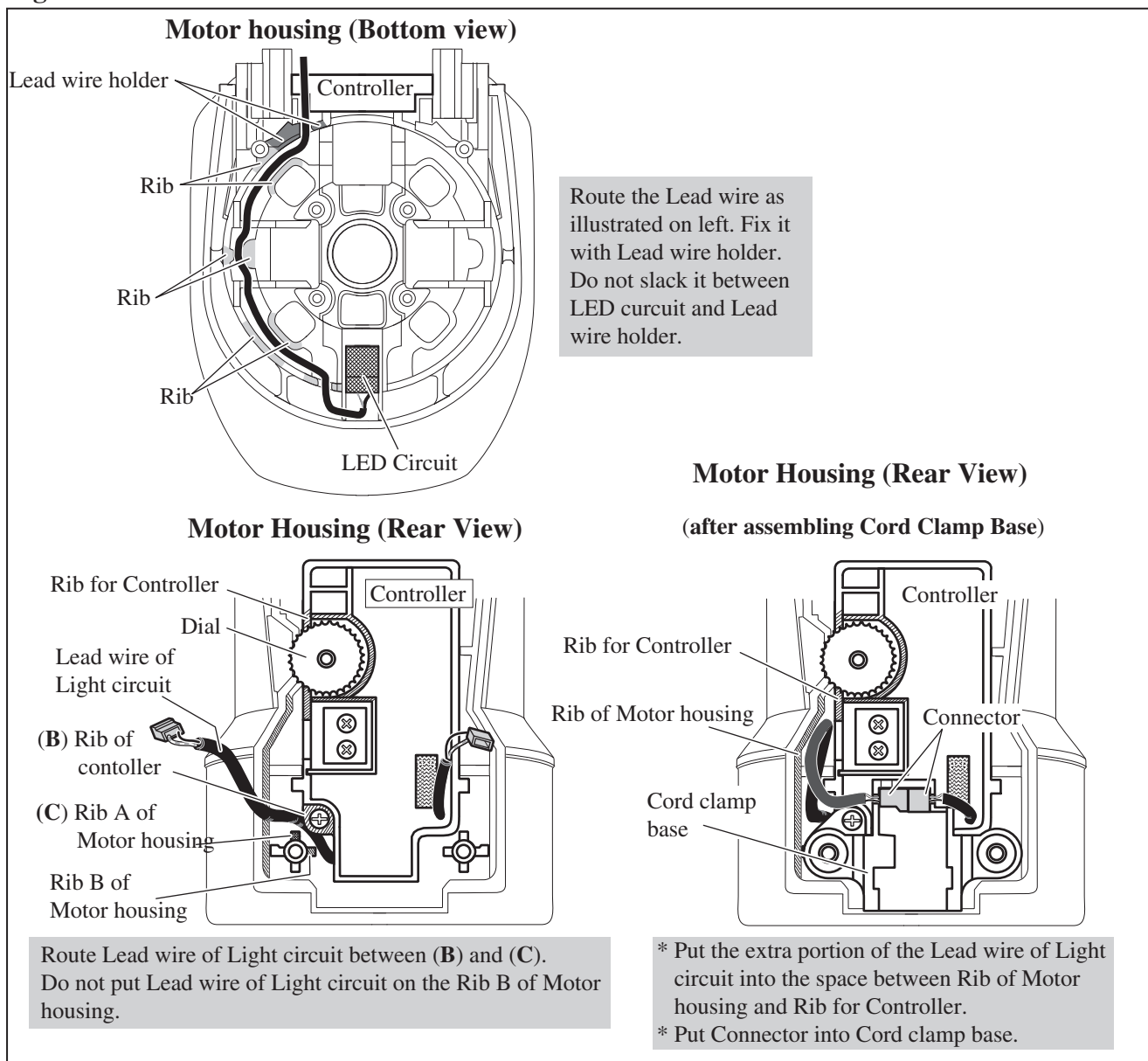
HR3210FCT

Fig. D-3



► **Wiring diagram**

Fig. D-4



► **Wiring diagram**

**HR3210FCT**

**Fig. D-5**

