

TECHNICAL INFORMATION



PRODUCT

P 1/1

Models No. ▶ LB1200F

Description ▶ Band Saw

CONCEPT AND MAIN APPLICATIONS

Model LB1200F is 305mm Band Saw with high cutting efficiency.

Its main features and benefits are:

- 6 LED job light that illuminate working surface for easier cutting in dark places.
- Wheeled stand for easier mobility
- Quick-release tension lever for tool-less easy blade change
- High/low speed selection for excellent results in both hard and soft wood

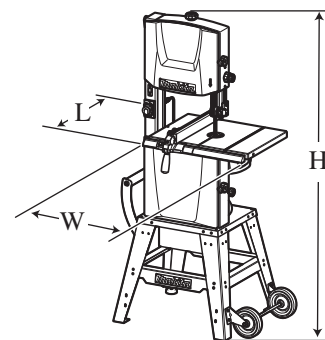

| Dimensions: mm (") | |
|--------------------|--------------|
| Length (L) | 615 (24-1/4) |
| Width (W) | 775 (30-1/2) |
| Height (H) | 1,600 (63) |

► Specification

| Voltage (V) | Current (A) | Cycle (Hz) | Continuous Rating (W) | | Max. Output (W) |
|-------------|-------------|------------|-----------------------|--------|-----------------|
| | | | Input | Output | |
| 110 - 120 | 8.2 | 50/ 60 | 900 | 660 | --- |
| 220 - 240 | 4.0 | 50/ 60 | 900 | 660 | --- |

| | | |
|---|------------------|-----------------------------|
| Cutting speed: m/s (m/min.) | 50 Hz: Low/ High | 6.7 (400)/ 13.3 (800) |
| | 60 Hz: Low/ High | 8.3 (500)/ 16.7 (1,000) |
| Blade size: mm (") | Circumference | 2,240 (88) |
| | Width | 6 (1/4), 13 (1/2), 16 (5/8) |
| Cutting capacities: mm (") | Maximum height | 165 (6-1/2) |
| | Throat width | 305 (12) |
| Mechanical speed control | | Yes (2 speed) |
| Protection against electric shock | | Grounding |
| LED job light | | Yes (6 LEDs) |
| Power supply cord: m (ft) | | 2.5 (8.2) |
| Weight according to EPTA-Procedure 01/2003*: kg (lbs) | | 81.2 (179.0) |

* with stand and band saw blade

► Standard equipment

| | | | |
|---|---|----------------------|---|
| Rip fence | 1 | Push stick | 2 |
| Miter gauge | 1 | Nozzle 93 | 1 |
| Saw blade for wood (6mm width) | 1 | Band saw stand | 1 |
| Saw blade for wood (13mm width) | 1 | Hex wrench 4 | 1 |
| Saw blade for wood (16mm width) | 1 | Hex wrench 5 | 1 |
| Saw blade for nonferrous metal (16mm width) | 1 | | |

Note: The standard equipment for the tool shown above may vary by country.

► Optional accessories

Extension table, Circular cutting attachment, Belt sanding attachment, Band saw blades, Dust collector port