

TECHNICAL INFORMATION



Product

Models No. ▶ HR2010

Description ▶ 20mm Rotary Hammer

CONCEPTION AND MAIN APPLICATIONS

HR2010 is designed to belooked stronger structure, with traditional "D" handle and some aluminium parts.

In overhead horizontal operations, HR2010 has great performance in drilling 6mm-12mm holes.

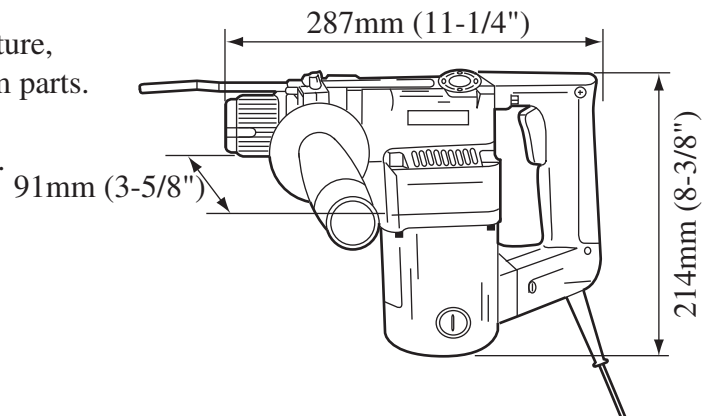

▶ Specifications

| | |
|--------------------------|------------------------------------------------------------|
| Dimension | 287mmx214mmx91mm (11 4/1"x8 3/8"x3 5/8") |
| Weight | 3.1Kgs (6.8lbs) |
| Power Supple Cord | 5m(16.4ft) (Note:4m=12ft for China and European Countries) |
| Insulation | Double Insulation |
| Motor | AC universal motor (72mm) |

Motor Features

| Voltage (V) | Amperage (A) | Frequency (Hertz) | Rated Input(W) | Rated Out-put(W) | Max. Output(W) |
|-------------|--------------|-------------------|----------------|------------------|----------------|
| 100 | 6.3 | 50/60 | 600 | 310 | 480 |
| 110 | 5.5 | 50/60 | 600 | 310 | 480 |
| 115 | 5.5 | 50/60 | 600 | 310 | 480 |
| 220 | 2.9 | 50/60 | 600 | 310 | 480 |
| 230 | 2.7 | 50/60 | 600 | 310 | 480 |
| 240 | 2.6 | 50/60 | 600 | 310 | 480 |

| | | |
|-------------------------|--------------------------|--------------|
| No load speed | 0-900rpm | |
| Blows per minute | 0-4000 | |
| Bit size | 10mm(3/8") SDS-Plus only | |
| Max.Capacities | Concrete | 20mm(13/16") |
| | Steel | 13mm(1/2") |
| | Wood | 24mm(15/16") |

▶ Standard equipment

Depth Rod, Side Grip, Plastic Carrying Case

▶ Optional accessories

Drill Chuck Assembly, Chuck Key S13, Holder Driver, Dust Cup 5, Blow-out Bulb, Lock Nut Wrench 28, Dust Collector Set

The standard equipment for the tools shown may differ from country to country.

► Repair

(1) Disassembling and assembling

1-1. Disassembling of chuck

Use the minus screw driver just like pushing up to disconnect the cap 37 as shown on the right figure.

Pull out the change ring cover.

Strongly pull out the change ring to disconnect it. If hard to disconnect, place the minus screw driver between clearance of leaf spring, expand the leaf spring just like twisting the driver, and then pull out it. It is fixed by steel ball and leaf spring.

Disconnect the roller 7(2 pieces).

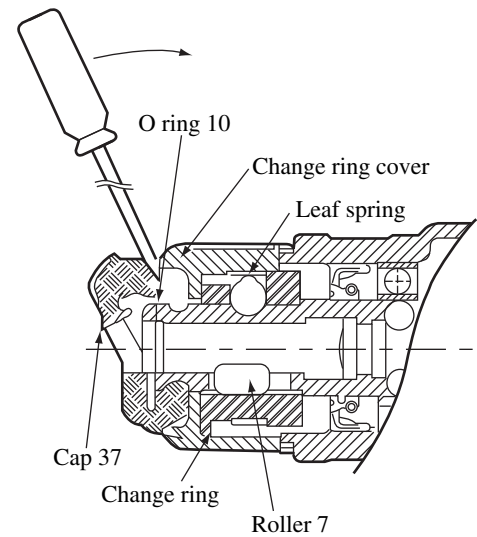

1-2. Assembling of chuck

Grease the MAKITA grease R No. 1 on the roller 7 and then assemble it.

2-1. Disassembling of barrel

Remove the hexagon socket bolt M5x20 and then remove the barrel.
Use the arbor press to press the top of tool holder to remove it.

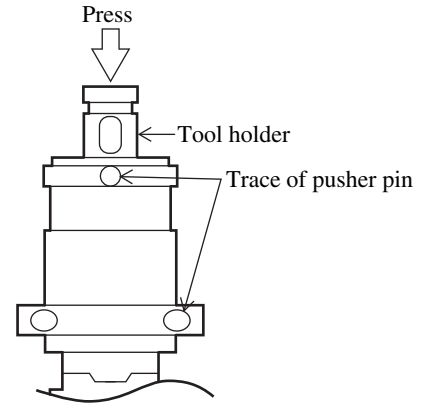

2-2. Assembling of barrel

Assemble in a way that the trace of pusher pin shown on the right figure comes at name plate side.

3-1. Disassembling of impact bolt

Use the screw driver to shift the impact bolt in the direction of tool holder edge as shown on the bottom-right figure.(in the direction of arrow 1)
Use the resin hammer to slightly hammer the tool holder as shown on the bottom-right figure to remove the four points of steel ball 5 and 6.
Use the sharpened-edge tool like an eyeleteer to pull out the O ring 11 as shown on the bottom-right figure. For easy disconnection, use the eyeleteer while 5 mm around of sharpened-edge tool edge is being bent by 90° around.
Use the driver edge to disconnect(push) the impact bolt.(in the direction of arrow 2)

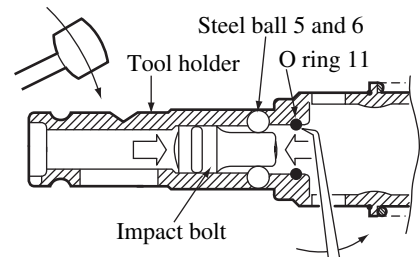

3-2. Assembling of impact bolt

Use the screw driver to insert the impact bolt into the tool holder.
Use the sharpened-edge tool to insert the O ring 11 into the groove of the tool holder. Move the impact bolt in the direction of arrow to check if O ring 11 cannot be disconnected.
Before placing the steel ball 5 and 6 in the tool holder, grease into the hole so that the steel ball cannot drop and the tool holder can be easily set.

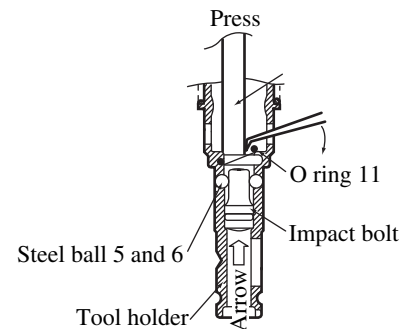

4-1. Disassembling of torque limiter

Use the circle clip pleyer to disconnect the circle clip(shaft)S-26 and then remove the spiral bevel gear 33, clutch cam and compression spring 31.
If hard to disconnect the parts, shift the flat washer 26 away from the circle clip groove since it is housed in said groove.

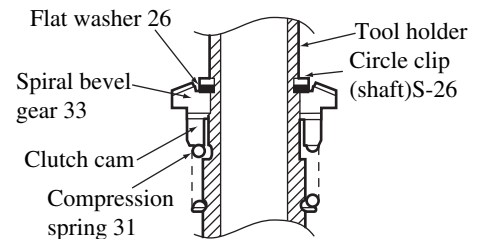

4-2. Assembling of torque limiter

Use care of direction of clutch cam when assembling the torque limiter.
Engage the protruded portion with the spiral bevel gear 33 while supporting the compression spring 31 by holding the dent face.

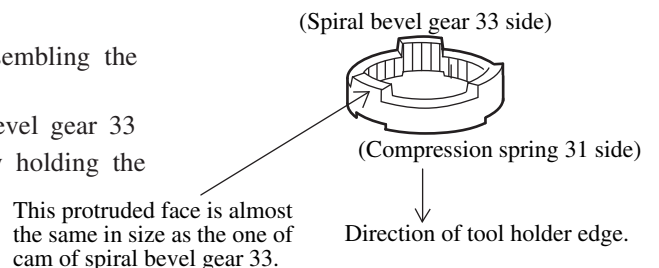

5-1. Disassembling of crank

To disassemble the handle set, disconnect the two points of pan head screw M5X25 connected on the crank housing complete and then disconnect the tapping screw PT5x25 connected on the motor housing complete.
To disassemble the motor housing complete, disconnect the hexagon holed bolt M5x45 connected on the gear housing complete and crank housing complete.
Separate the crank housing from the gear housing.
Use the lock nut wrench 28 to disconnect the crank cap.

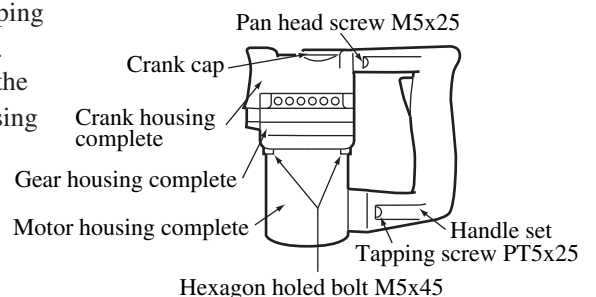

Push the crank shaft from the crank cap side to pull out it as shown on the bottom-right figure.
 Since the ball bearing 6001, ball bearing 6002, helical gear 43 and helical gear 29 are inserted by pressing, use the arbor press to pull out them.
 At this time use care not to miss the flat washer 8.

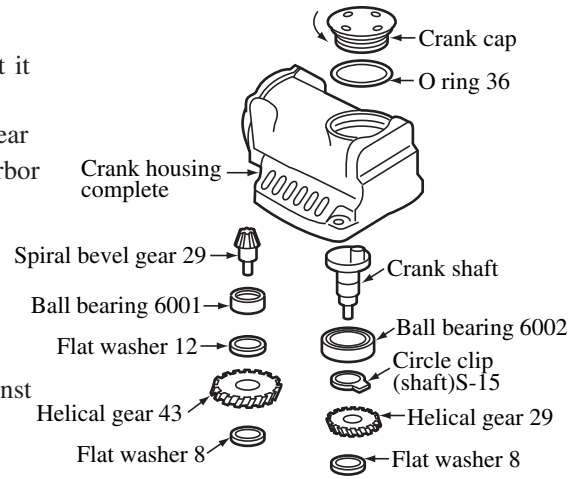

5-2. Assembling of crank

For assembling, follow in the reverse order against disassembling.

6-1. Replacing of armature

Disconnect the holder cap from the motor housing complete to pull out the carbon brush.
 Use the resin hammer to disconnect the one body of armature complete and gear housing complete from the motor housing complete.
 Pull out the armature complete while holding the gear housing complete.

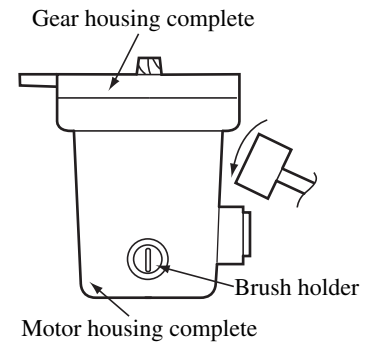

6-2. Assembling of armature

Assemble the ball bearing 6000 and oil seal 12 on the gear housing complete before inserting the armature.
 Note) If one body assembled with ball bearing and oil seal is inserted into the armature, the oil seal cannot be completely inserted and it may cause oil leaking.

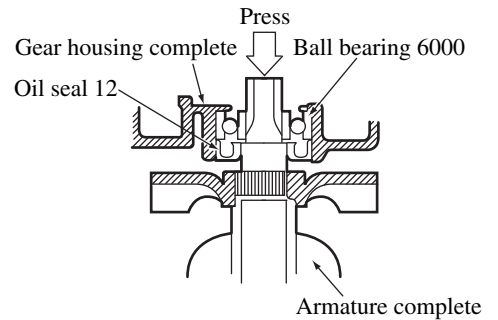

(2) Lubricating points

To avoid abrasion at earlier stage and heating damage, apply the MAKITA oil XLD on the points shown below.

- 1) O ring on the impact bolt

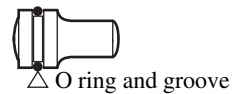

- 2) Outer circumference of the striker and O ring

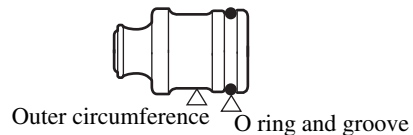

- 3) Outer circumference of piston and O ring

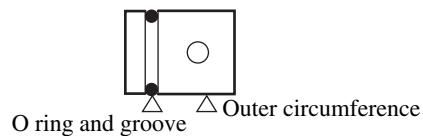

To avoid abrasion at earlier stage and heating damage, use the MAKITA grease R No. 00 to grease on the points shown below.

- 1) Outer circumference of pin5
- 2) Each teeth face of Helical gear 43, Helical gear 29, spiral bevel gear 9 and spiral bevel gear 33
- 3) Cam of spiral bevel gear 33 and cam of clutch cam
- 4) Flat washer 8 Both edges on flat washer 23
- 5) Lip face of oil seal 20
- 6) Needle bearing 810

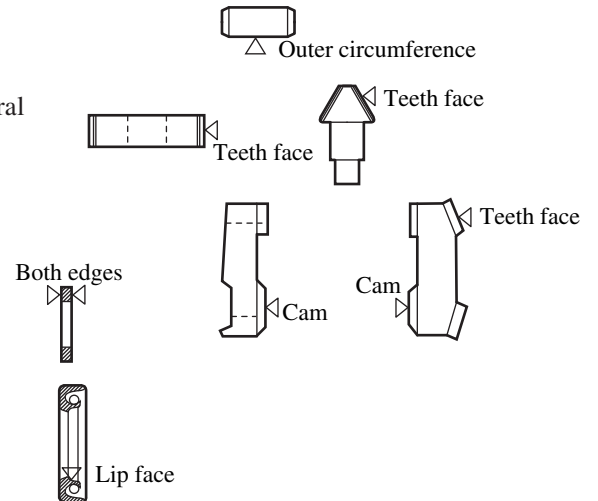

(3) Necessary tools

- 1) + screw driver
- 2) - screw driver
- 3) Arbor press
- 4) Resin hammer or wooden hammer
- 5) Radio cutting pleyer
- 6) Sharpened-edge tool like an eyeleteer
- 7) O ring inserting jig