

# T ECHNICAL INFORMATION

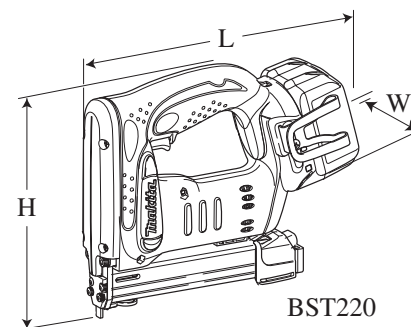


PRODUCT

P 1 / 9

**Models No.** ▶ BST220, BST221

**Description** ▶ Cordless Stapler



## CONCEPT AND MAIN APPLICATIONS

Model BST220/ BST221 has been developed as cordless stapler with 14.4V/ 18V Li-ion battery.

Machined aluminum magazine provides precision and durability to ensure smooth staple loading and feeding, also allowing for the use of commercial staples.

The other features are as follows:

- Rubberized soft grip
- Hook
- Easy-to-repair construction

Dimensions: mm (")		
	BST220	BST221
Length (L)	247 (9-3/4)	251 (9-7/8)
Width (W)	91 (3-5/8)	
Height (H)	212 (8-3/8)	

## ► Specification

Specifications		Model No.		BST220 / BST221	
Battery	Voltage: V	14.4		18	
	Capacity: Ah	3.0			
	Cell	Li-ion			
	Charging time: min	22 (with DC18RA)			
Staple	Width: mm	10			
	Length: mm (")	10, 13, 16, 19, 22 (3/8, 1/2, 5/8, 3/4, 7/8)			
	Gauge: mm (")	0.6x1.2 (1/32x1/16)			
Magazine capacity: pcs.	pcs. per sheet	84 a sheet			
	Maximum	98			
Material of Magazine		Aluminum			
Remaining staple view window		Yes			
Driving mechanism		Spring drive			
Trigger		Single			
Contact arm		Yes			
Depth control		Yes			
Hook		Yes			
Rubberized soft grip		Yes			
Dimensions: mm (")	Length	247 (9-3/4)		251 (9-7/8)	
	Width	91 (3-5/8)			
	Height	212 (8-3/8)			
Net weight: kg (lbs)		2.2 (4.9)		2.3 (5.1)	

## ► Standard equipment

- Safety goggle ..... 1  
 Hook ..... 1

**Note:** The standard equipment for the tool shown above may differ by country.

## ► Optional accessories

- 10mm width Staples: length 10mm (3/8"), 13mm (1/2"), 16mm (5/8"), 19mm (3/4"), 22mm (7/8")  
 Battery chargers DC18RA, DC24SA, DC24SC  
 Li-ion Batteries BL1415, BL1815

► **Repair**

**CAUTION: Remove Battery and Staple for safety before repair/ maintenance.**

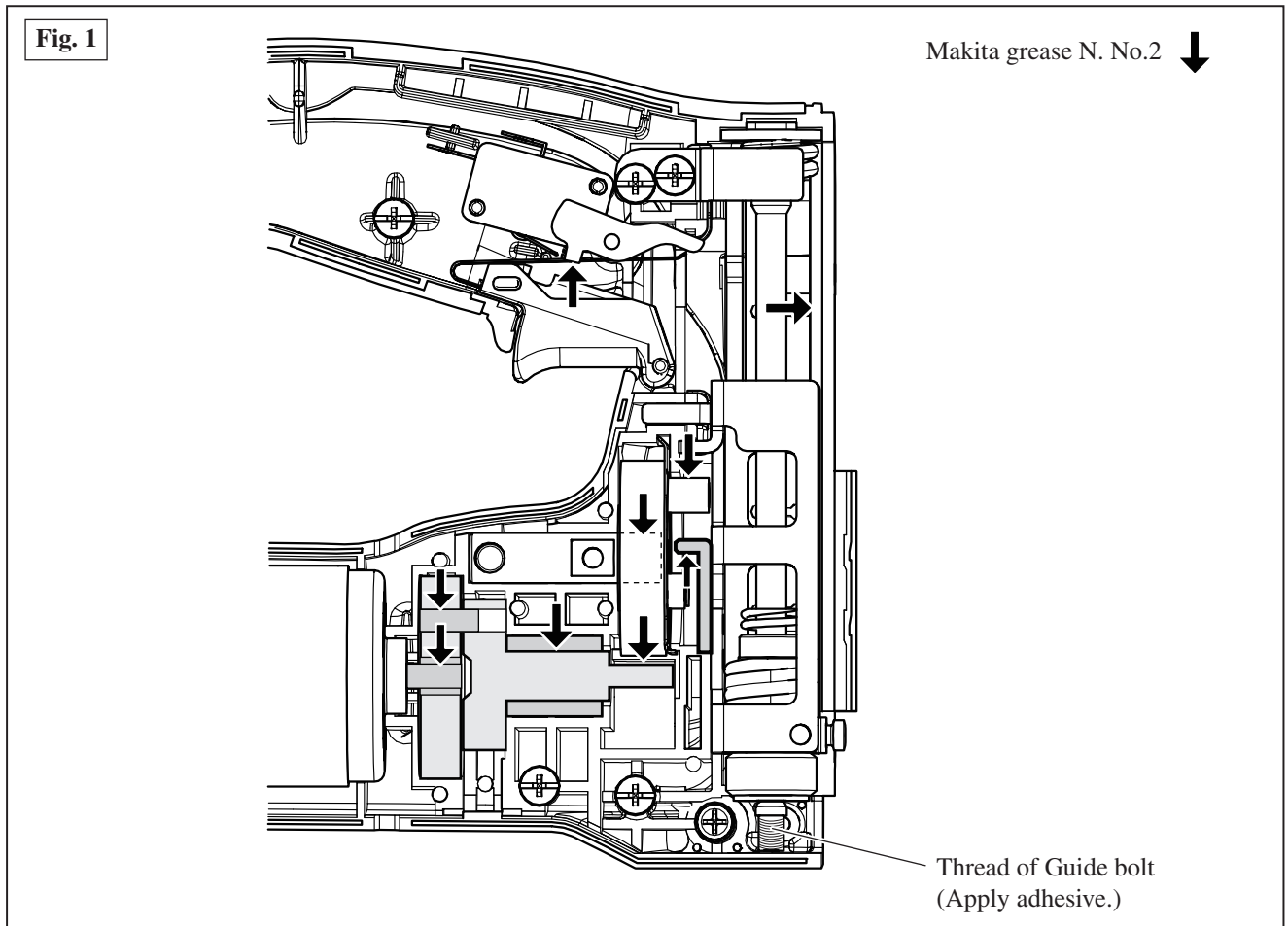
**[1] NECESSARY REPAIRING TOOLS**

Code No.	Description	Use for
1R220	Ratchet head 9.5	Tightening Hex socket head bolts to the specific torque
1R222	Socket Adapter	
1R254	Torque wrench shaft 2-6N.m	
1R228	1/4" Hex. shank bit for M4	Tightening Hex socket head bolts
1R229	1/4" Hex. shank bit for M5	
1R230	1/4" Hex. shank bit for M6	

**[2] LUBRICATION**

Apply **Makita grease N. No.2** to the portions designated with the **black triangle** to protect parts and product from unusual abrasion.

When removing Guide bolt, be sure to apply ThreeBond 1303B / Loctite 272 to the thread before assembling.



**[3] FASTENING TORQUE TO BOLTS AND SCREWS**

- M4x14 Hex. socket head bolts mainly for Driver guide and Magazine complete.....2.0 up to 3.0 N.m.
- M5x18 Hex. socket head bolts mainly for Driver guide and Holder.....4.9 up to 7.4 N.m.
- M4x4 Pan head screw mainly for Adjuster base.....0.6 up to 1.0 N.m.

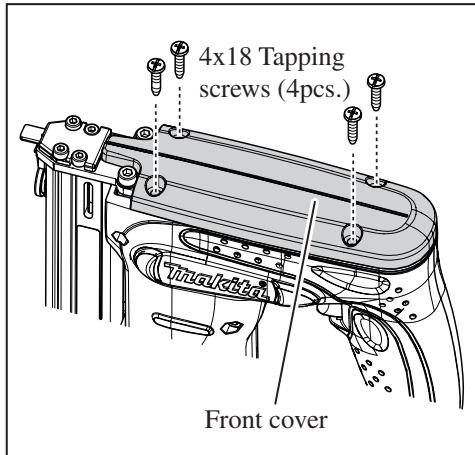
► **Repair**

**[4] DISASSEMBLY/ ASSEMBLY**

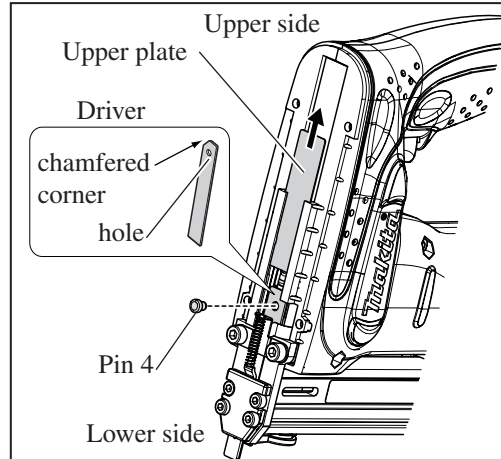
**[4]-1. Replacing Driver**

- 1) Remove 4x18 Tapping screws (4pcs.) and Front cover. (Fig. 2)
- 2) Slide Upper plate out of the grooves, then pull out Pin 4 for connecting Driver and Hammer. (Fig. 3)  
Driver can be replaced.
- 3) Take the disassembling step in reverse. Face the hole of Driver to the upper side.  
The chamfered corner of Driver is allowed to face either right or left side. (Fig. 3)

**Fig. 2**



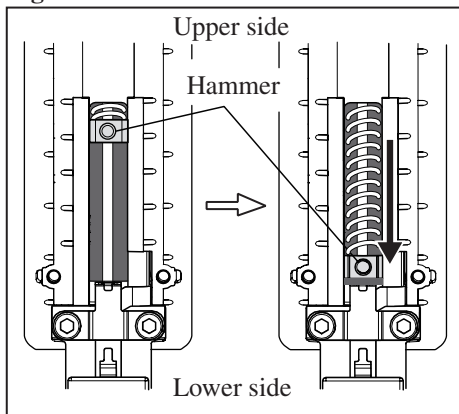
**Fig. 3**



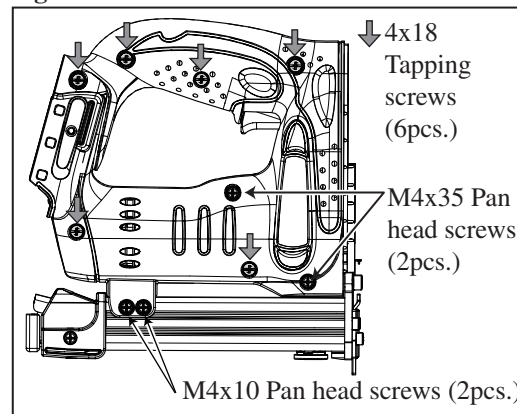
**[4]-2. Disassembling Motor, Switch, Terminal**

- 1) Remove Front cover, 4x18 Tapping screws (4pcs.), Upper plate, Pin 4 and Driver.
- 2) Remove Compression spring 4. (Fig. 8)
- 3) When Hammer is not located at the lowest position (i.e., the left illustration of Fig. 4);
  1. Install Battery.
  2. Pull Trigger in a blink and release it repeatedly until Hammer reaches the lowest position. (the right illustration of Fig.4)
 The pressure of Compression springs is now disappeared. Remove Battery.
- 4) Remove 4x18 Tapping screws (6pcs.), M4x10 Pan head screws (2pcs.), M4x35 Pan head screws (2pcs.) and Housing R while holding Trigger to prevent popping out. (Fig. 5) Switch and Terminal can be replaced.
- 5) Remove Spur gear 55 complete, and then lever up Spur gear 7 complete with slotted screwdriver. (Fig. 6)  
Internal gear 69, DC motor and their linked parts come with Spur gear 7 complete.

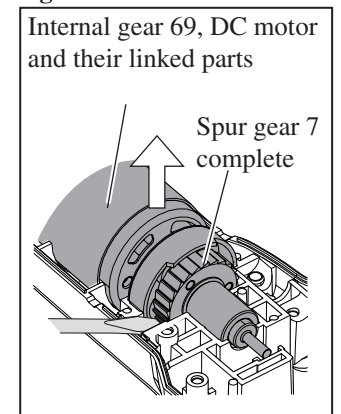
**Fig. 4**



**Fig. 5**

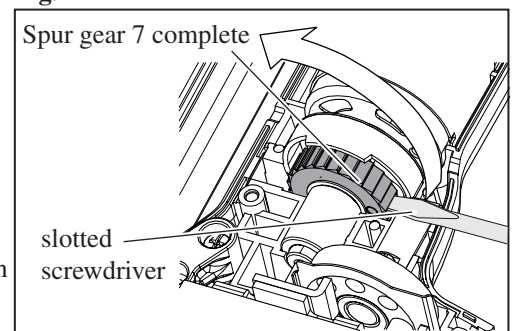


**Fig. 6**



- Note:** In the event of failure on Motor and Switch, Compression springs in Driving section remain compressed. Consequently, DC motor can not be removed due to the pressure. Therefore, take the following step while holding the around of Trigger with cloth to prevent popping out. (Be careful not to pinch your hand between Hammer and Cushion.)
1. Insert slotted screwdriver between the gear teeth of Spur gear 7 complete.
  2. Revolve Spur gear 7 complete by moving a gear tooth to the direction designed in white arrow with the slotted screwdriver.

**Fig. 7**



► **Repair**

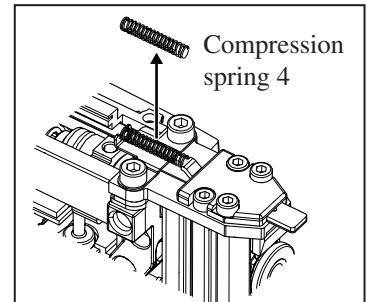
**[4] DISASSEMBLY/ ASSEMBLY**

**[4]-3. Hammer, Cushion**

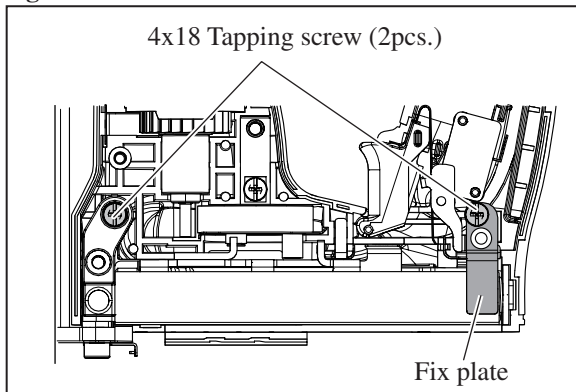
**DISASSEMBLING**

- 1) Remove Housing R. (Refer to previous page.)
- 2) Remove Compression spring 4. (**Fig. 8**)
- 3) Remove Fix plate and 4x18 Tapping screws (2pcs.) (**Fig. 9**)
- 4) Remove Safety lever guide and M4x6 Hex. socket head bolts (2pcs.), then loosen M5x18 Hex. socket head screws (2pcs.) with Hex wrench 5 and 1R230. (**Fig. 10**)
- 5) Remove Magazine section.
- 6) Remove Guide plate, Hammer driving section and Safety cover. (**Fig. 11**)
- 7) Remove Slide plate from Housing L. (**Fig. 12**)

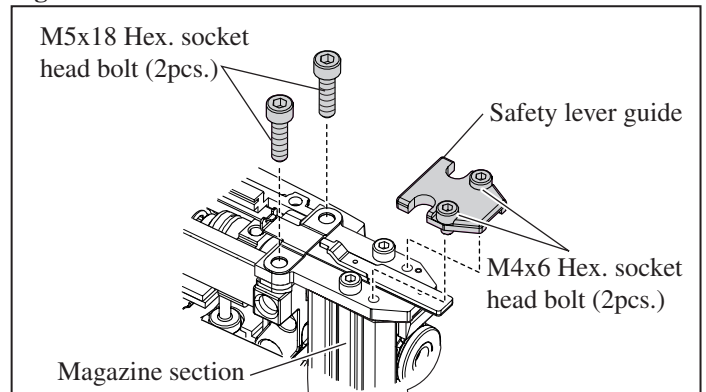
**Fig. 8**



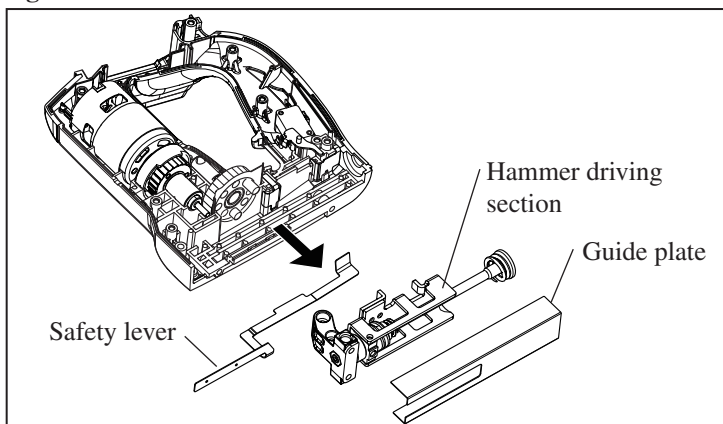
**Fig. 9**



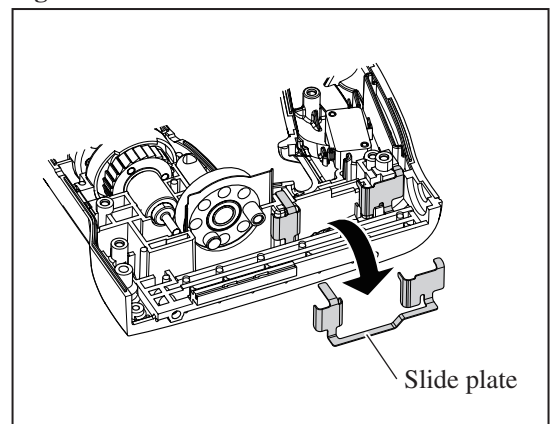
**Fig. 10**



**Fig. 11**

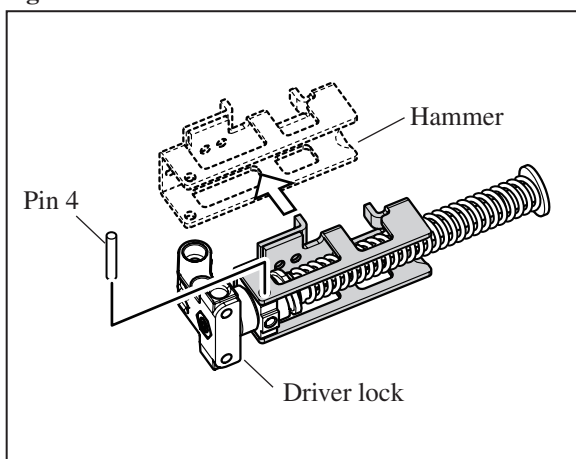


**Fig. 12**

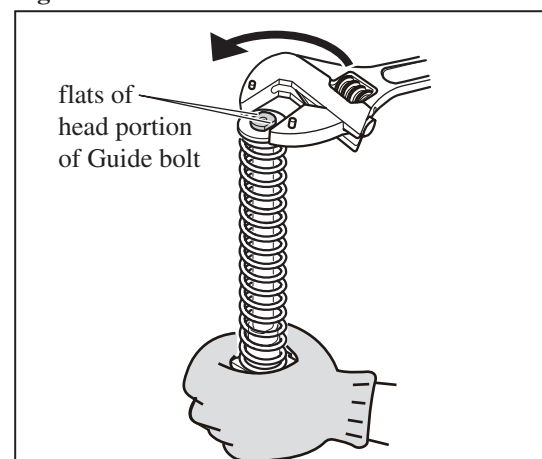


- 8) Remove Hammer by pulling out Pin 4 from Driver lock. (**Fig. 13**)
- 9) While holding Holder portion by gloved hand as illustrated in **Fig. 14** (or clamping in vise), loosen Guide bolt by hooking the flats and turning counterclockwise by monkey wrenches. When Guide bolt is separated, Compression springs is slightly released.
- 10) Cushion etc. held in the gloved hand are removed as illustrated in **Fig. 17** of next page.

**Fig. 13**



**Fig. 14**



► **Repair**

**[4] DISASSEMBLY/ ASSEMBLY**

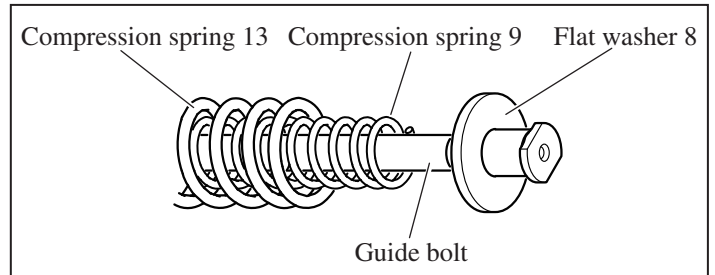
**[4]-3. Hammer, Cushion (cont.)**

**ASSEMBLING**

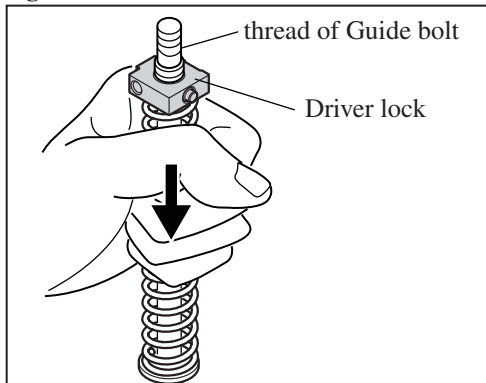
- 1) As illustrated in **Fig. 15**, set Compression springs 13 and 9 in place on Guide bolt after installing Flat washer 8.
- 2) Pass Guide bolt through Driver lock. While pressing the compression springs onto worktable, mount the following parts on Compression spring 13.
  - M6 Hex. nut
  - Holder
  - Flat washer 6
  - Cushion
  - Driver lock
  - Spring holder

- Note:**
1. When loosening Guide bolt, apply ThreeBond 1303B or Loctite 272 to the thread of Guide bolt.
  2. Fit the inner lip of Cushion into the groove on Guide bolt completely, or M6 Hex. nut will not be installed firmly to the thread of Guide bolt.

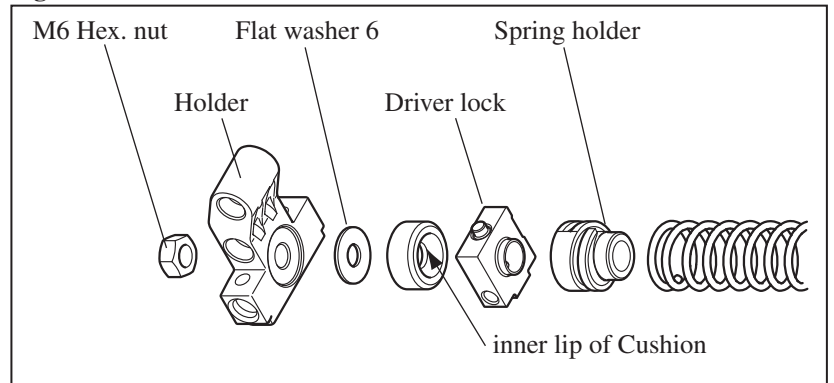
**Fig. 15**



**Fig. 16**

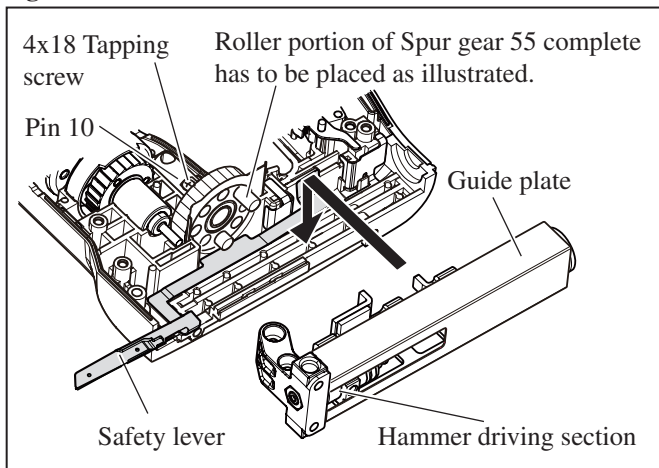


**Fig. 17**

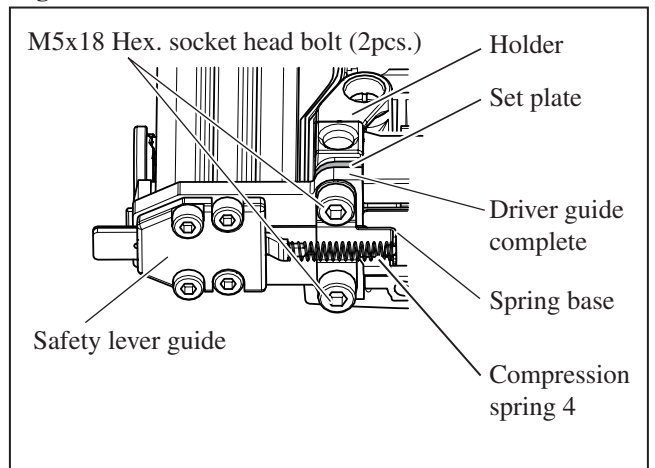


- 3) Move Spur gear 55 complete until the roller portion is placed as illustrated in **Fig. 18**, and secure Pin 10 to Housing L by tightening 4x18 Tapping screw.
- 4) Mount Safety lever on Housing L.
- 5) Cover Hammer driving section with Guide plate, and install them into Housing L. (**Fig. 18**)
- 6) Check that Safety lever can be slid smoothly.
- 7) Secure both ends of Hammer driving section with 4x18 Tapping screws (2pcs.) and Fix plate. (**Fig. 9**)
- 8) Move Safety lever to the forward position to the full. And then put Set plate between Holder and Driver guide complete. Fasten them to Magazine section by tightening M5x18 Hex. socket head bolts (2pcs.). (**Fig. 19**)
- 9) Secure Safety lever guide by tightening M4x6 Hex. socket head bolts (2pcs.). (**Fig. 10**)
- 10) Set Compression spring 4 in place. (**Fig. 19**)

**Fig. 18**



**Fig. 19**



► **Repair**

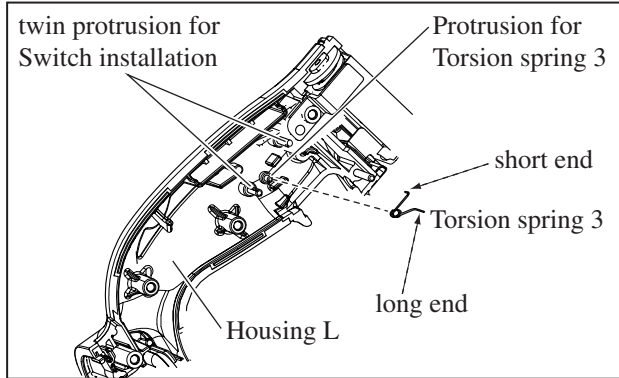
**[4] DISASSEMBLY/ ASSEMBLY**

**[4]-4. Switch, Trigger**

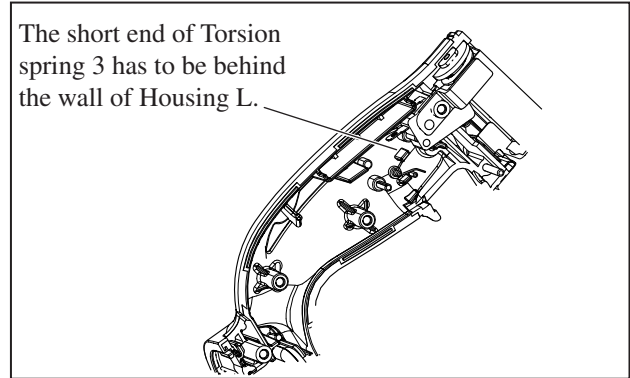
ASSEMBLING

- 1) Hook Torsion spring 3 with the protrusion of Housing L. (Fig. 20)
- 2) Attach the short end to the wall of Housing L. (Fig. 21)
- 3) After inserting Switch to twin protrusion, set Trigger and the linked parts in place as illustrated in Fig. 22.

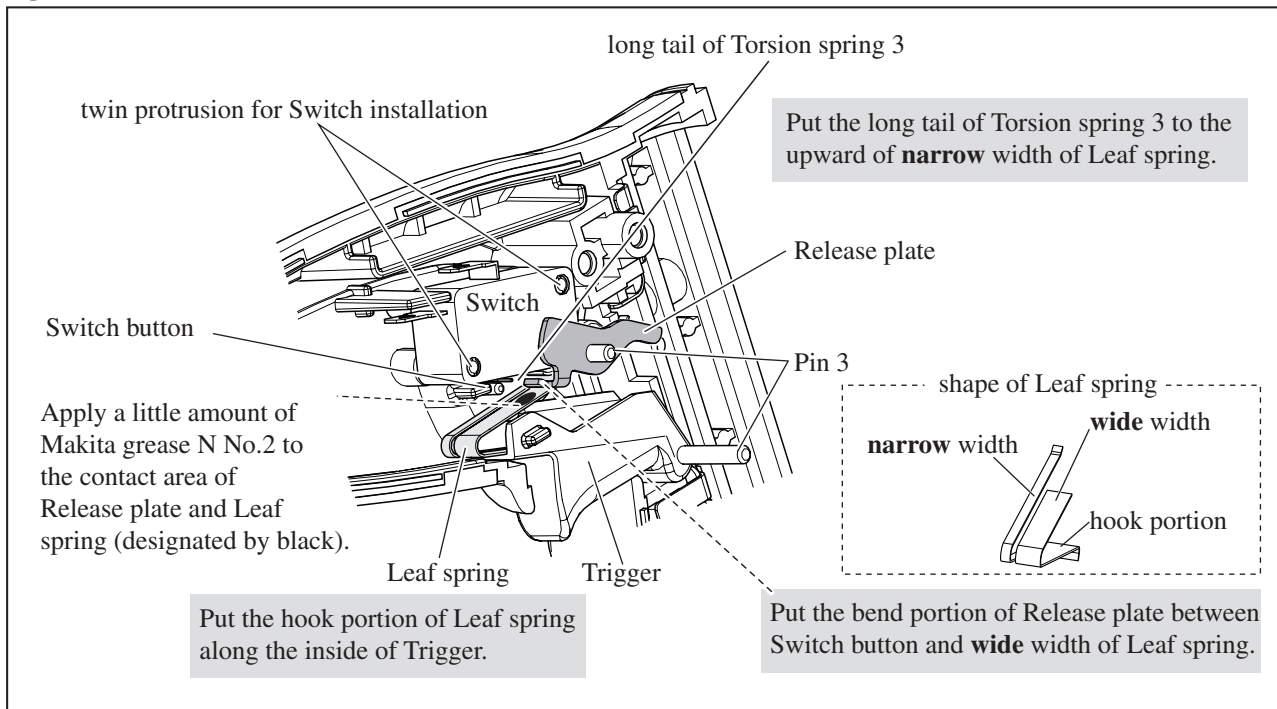
**Fig. 20**



**Fig. 21**



**Fig. 22**



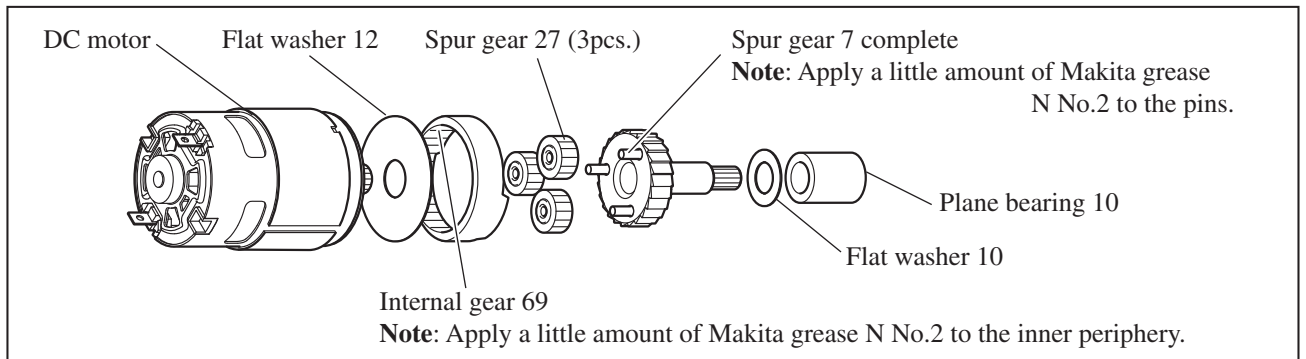
► **Repair**

**[4] DISASSEMBLY/ ASSEMBLY**

**[4]-5. Replacing Gear section**

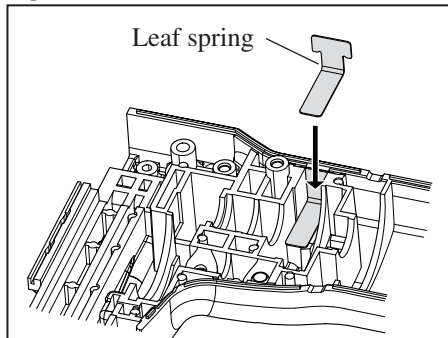
- 1) Remove DC motor section in accordance with **the clause [4]-2.**
- 2) Disassemble Gear section as illustrated in **Fig. 23.**

**Fig. 23**

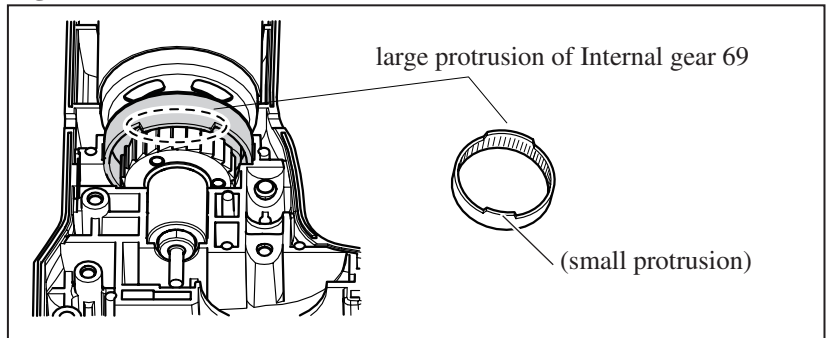


- 3) Remove Leaf spring from Housing L. (**Fig. 24**)
- 4) Cover the pins of Spur gear 7 complete with Internal gear 69. Refer to the direction of Internal gear 69. (**Fig. 23**)
- 5) After inserting the pins of Spur gear 7 complete into Spur gears 27 (3pcs.), mount Flat washer 12 on Internal gear 69.
- 6) Install the assembled parts (Flat washer 12, Internal gear 69, Spur gear 27 (3pcs.) and Spur gear 7 complete) into Housing L so that the large protrusion of Internal gear 69 can be seen. (**Fig. 25**)
- 7) Insert Leaf spring into Housing L. (Inserting Leaf spring into Housing L before installation of the assembled parts causes difficulty.)
- 8) Plate and Spur gear 55 complete have to be fixed as illustrated in **Fig. 26.** Refer to their directions.

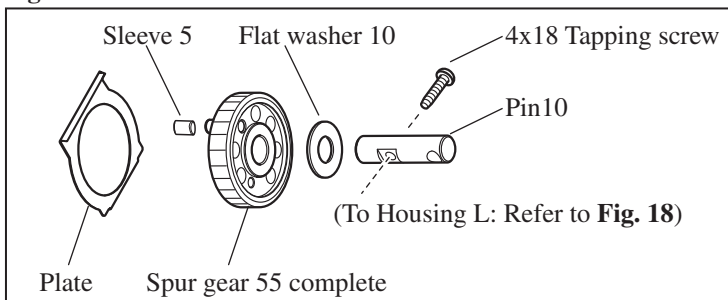
**Fig. 24**



**Fig. 24**



**Fig. 26**



► **Repair**

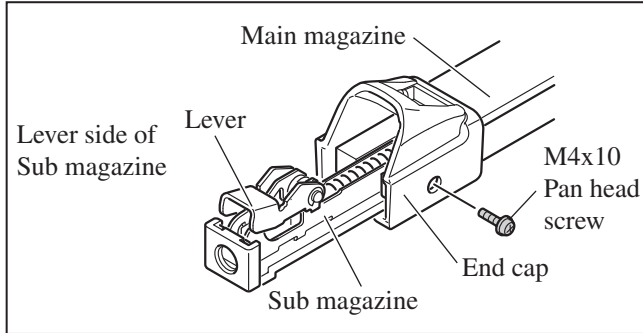
**[4] DISASSEMBLY/ ASSEMBLY**

**[4]-6. Magazine section**

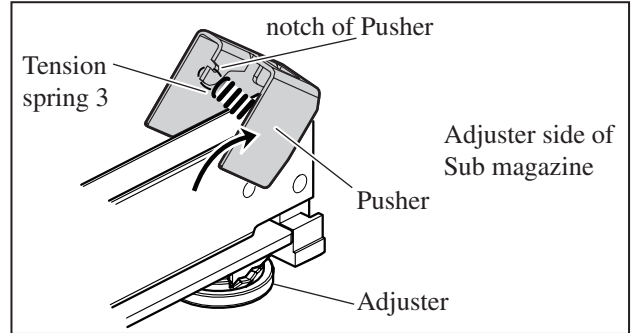
**DISASSEMBLING**

- 1) Remove M4x10 Pan head screw, and then pull out Sub magazine from Main magazine.
- 2) Pivot Pusher and Separate it from Tension spring 3 and Sub magazine.
- 3) Remove Stop ring E-3 from Pin 4. Lever portion can be removed.

**Fig. 27**



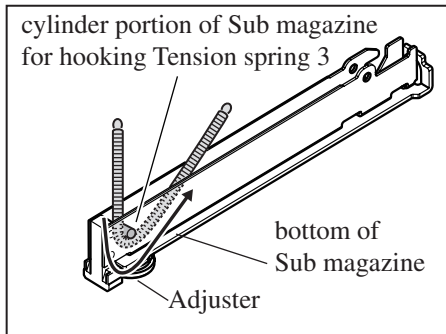
**Fig. 28**



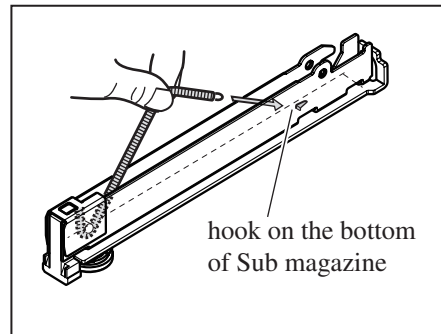
**ASSEMBLING**

- 1) Pass Tension spring 3 between cylinder portion and bottom of Sub magazine. (**Fig. 29**)
- 2) Hook the spring end on Adjuster side with the notch of Pusher. (**Fig. 28**)
- 3) Pick up the other spring end using Pincette. And hook the spring end with the hook on the bottom of Sub magazine as illustrated in **Fig. 30**.

**Fig. 29**

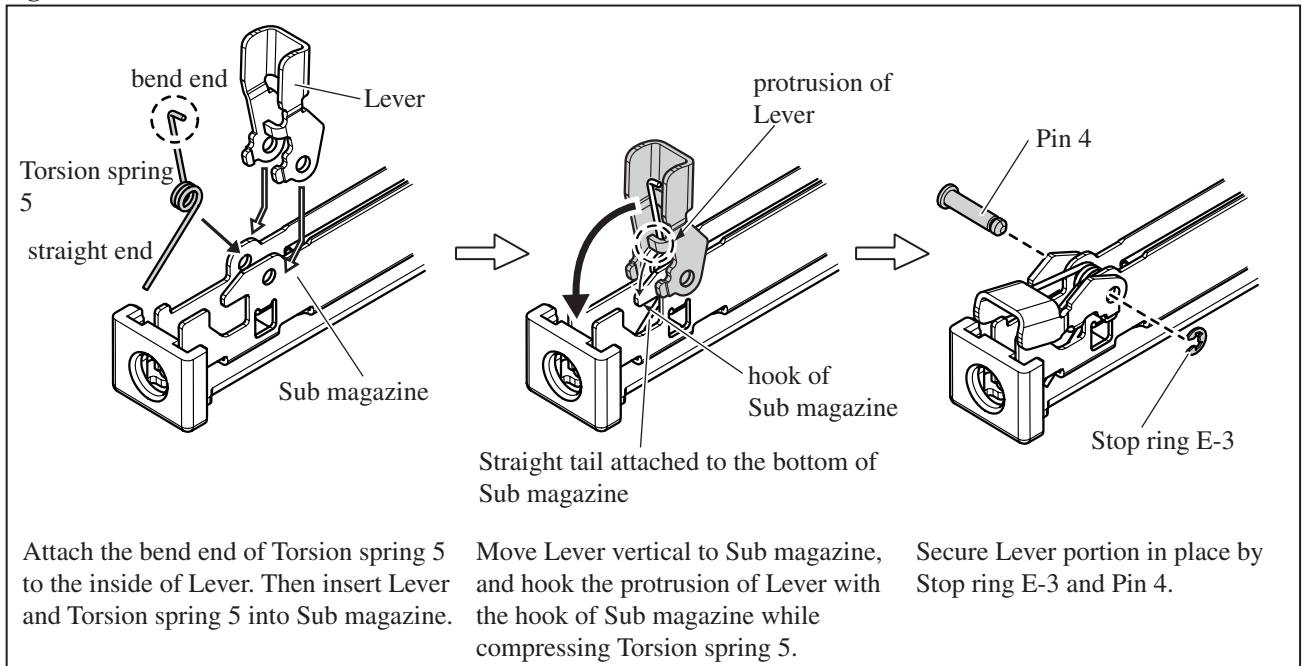


**Fig. 30**



- 4) As for Lever portion, assembling the components in accordance with the way illustrated in **Fig. 31**.

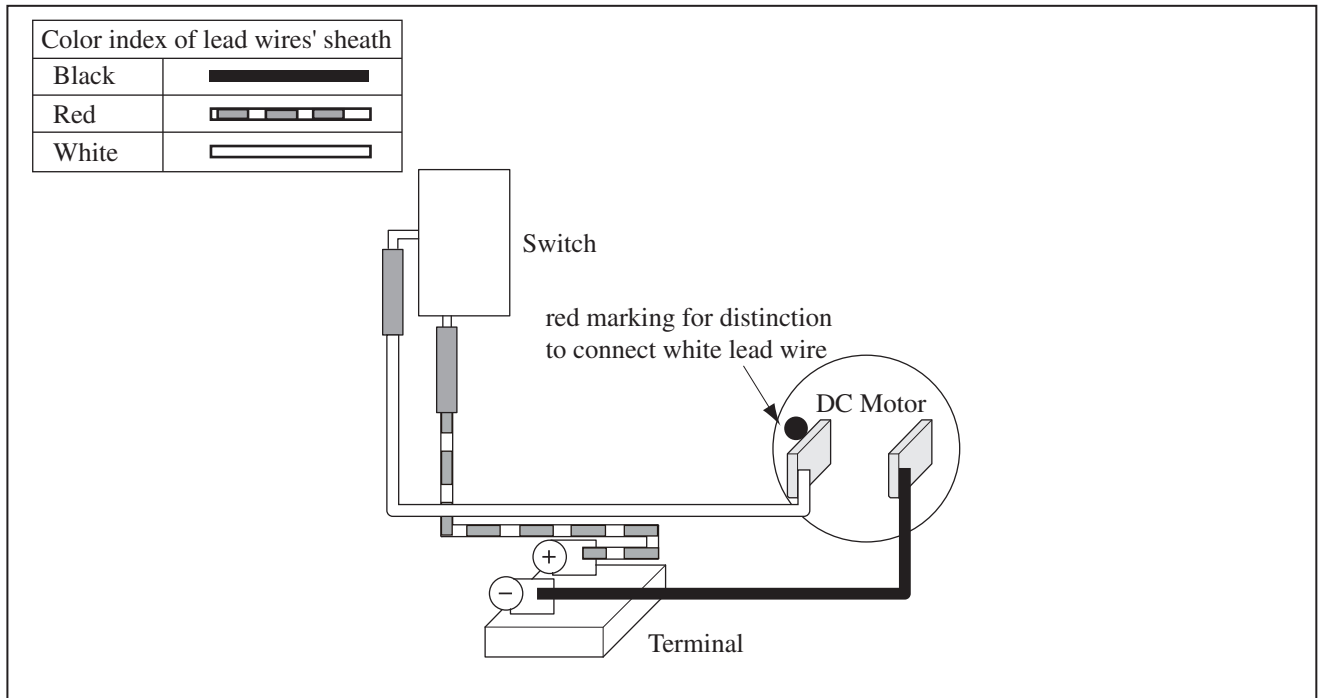
**Fig. 31**





► **Circuit diagram**

Fig. D-1



► **Wiring diagram**

Fig. D-2

