

TECHNICAL INFORMATION



PRODUCT

P 1 / 8

Models No. ▶ 9032

Description ▶ 9mm (3/8") Belt sander

CONCEPTION AND MAIN APPLICATIONS

MAKITA new power-file sander enables you to file and sand in awkward and confined areas, replacing manual work.

Various sanding arms and sanding belt widths, 6mm (1/4"), 9mm (3/8") and 13mm (1/2"), assure a wider range of sanding and filing applications.

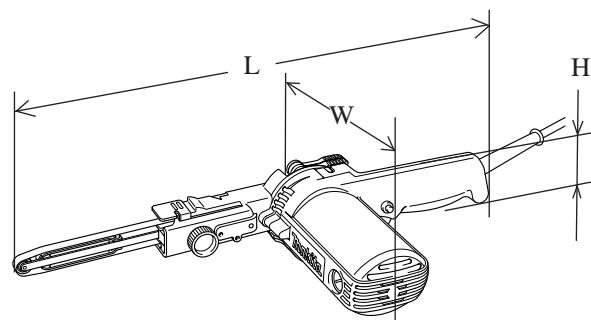

| Dimensions : mm (") | |
|-----------------------|--------------|
| Length (L) | 420 (16-1/2) |
| Height (H) | 78 (3-1/16) |
| Width (W) | 158 (6-1/4) |

► Specification

| Voltage (V) | Current (A) | Cycle (Hz) | Continuous Rating (W) | | Max. Output(W) |
|-------------|-------------|------------|-----------------------|--------|----------------|
| | | | Input | Output | |
| 110 | 4.8 | 50 / 60 | 500 | 200 | 500 |
| 120 | 4.4 | 50 / 60 | 500 | 200 | 500 |
| 220 | 2.4 | 50 / 60 | 500 | 200 | 500 |
| 230 | 2.3 | 50 / 60 | 500 | 200 | 500 |
| 240 | 2.2 | 50 / 60 | 500 | 200 | 500 |

| | |
|------------------------------------|----------------------------|
| Belt size : mm (") | 9 x 533 (3/8 x 21) |
| Belt speed : m / min. (ft / min.) | 300 - 1,700 (980 - 5,600) |
| Max. sanding length : mm (") | 110 (4-5/16) |
| Variable speed switch | Yes |
| Protection from electric shock | by double insulation |
| Net weight : Kg (lbs) | 1.5 (3.3) |
| Power supply cord : m (ft) | 2.5 (8.2) * 2.0 (6.6) |

* 2.0 (6.6) for Australia

► Standard equipment

- * Sanding belt 9 - 533 grit 80 2 pcs.
- * Dust nozzle assembly 1 pc. (only for European countries)

< Note > The standard equipment for the tool shown may differ from country to country.

► Optional accessories

- * 6mm (1/4") Arm assembly
- * 9mm (3/8") Arm assembly
- * 13mm (1/2") Arm assembly
- * Sanding belt 6 (1/4") x 533 (21") grit 40,60,80,100,120,(each grit 10 pcs. per pack)
- * Sanding belt 9 (3/8") x 533 (21") grit 40,60,80,100,120, (each grit 10 pcs. per pack)
- * Sanding belt 13 (1/2") x 533 (21") grit 40,60,80,100,120, (each grit 10 pcs. per pack)
- * Dust nozzle assembly
- * Hose 28 for connecting Model 420S
- * Joint 25

< 1 > Lubrication

Apply a little MAKITA grease N No.2 to the following portions marked with black triangle to protect parts and machine from unusual abrasion. See Fig. 1.

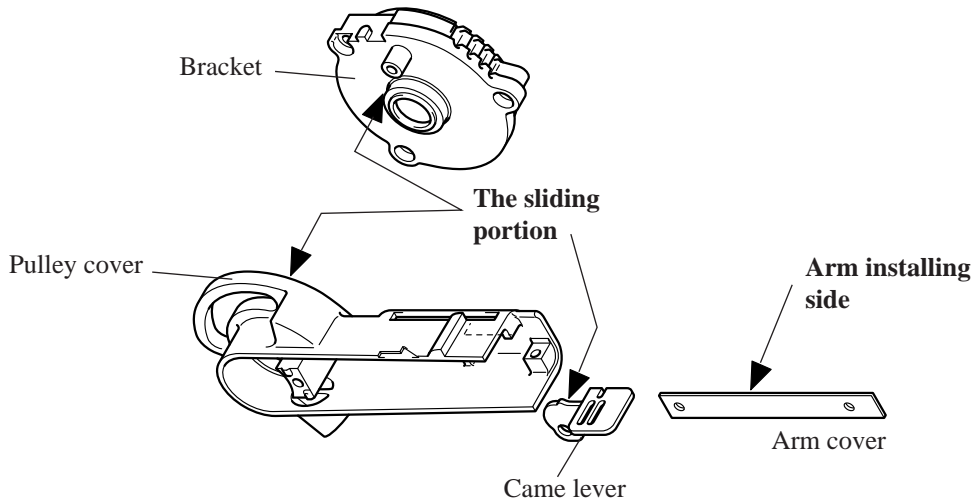

Fig. 1

< 2 > Disassembling ball bearing at the top of arm (Only for the arms of 9mm and 13mm width)

Put arm on No.1R032 "bearing setting plate", and keep the arm horizontal by supporting it with No. 1R033 "bearing setting plate". And set No.1R278 "round bar for arbor" on pin 4. See Fig. 2. Press No.1R278 "round bar for arbor" with arbor press. So, ball bearing and 2 pcs. of flat washers can be disassembled from arm. See Fig. 2A.

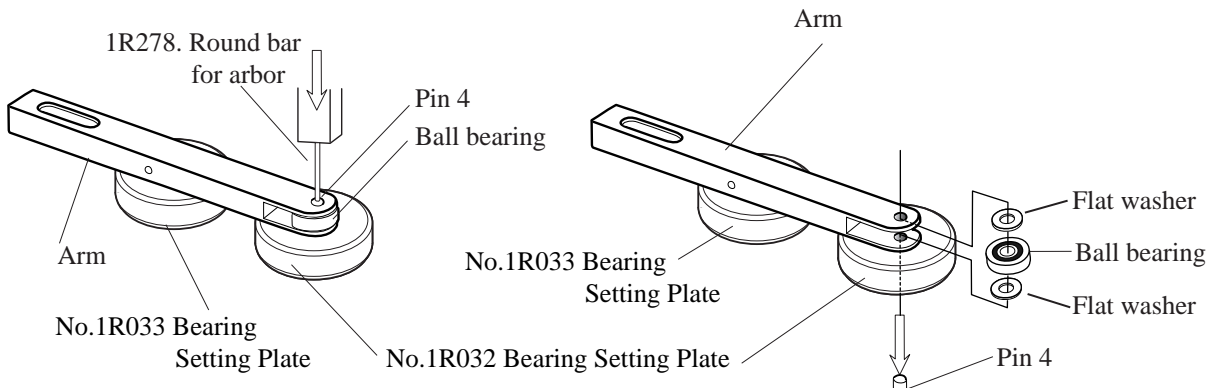

Fig. 2

Fig. 2A

< 3 > Assembling ball bearing at the top of arm (Only for the arms of 9mm and 13mm width)

Align the holes of flat washers with the hole of ball bearing by applying 1R278. "round bar for arbor" as illustrated in Fig. 3.

After putting pin 4 on the aligned holes, press the 1R278. "round bar for arbor" put on pin 4, with arbor press as illustrated in Fig. 3 A.

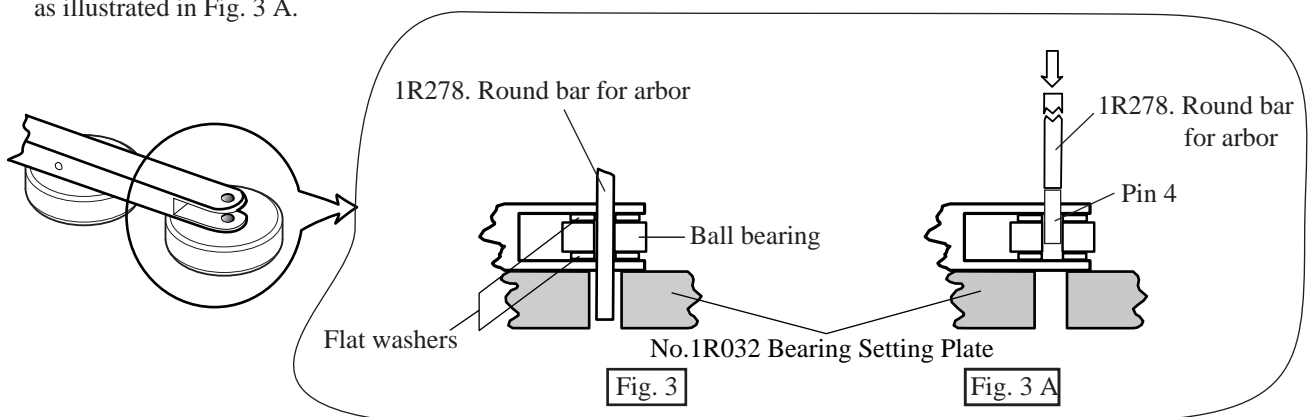

Fig. 3

Fig. 3 A

< Note > As for arm of 6mm width, ball bearing and axis are integral part of arm, which can not be removed.

< 4 > Disassembling arm section

(1) Set cam lever to lock position by pushing it in the direction of arrow as illustrated in Fig 4.

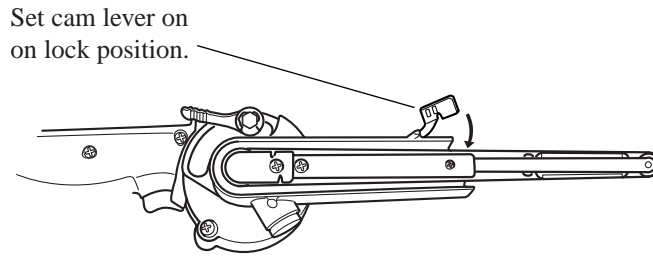

Fig. 4

(2) Compression spring 6 is installed in arm holder. Press the center of arm cover with your finger so that the spring does not jump out. And unscrew pan head screw M4 x 20 and hex socket head bolt M4 x 10 as illustrated in Fig 4 A. After taking off screws, slowly relax your grip on arm cover. Then, arm section can be disassembled as illustrated in Fig. 4 B.

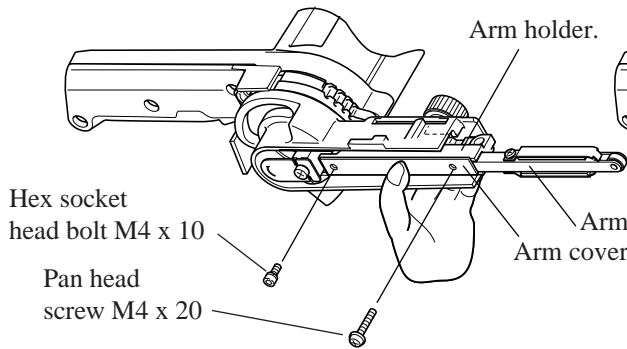

Fig 4 A

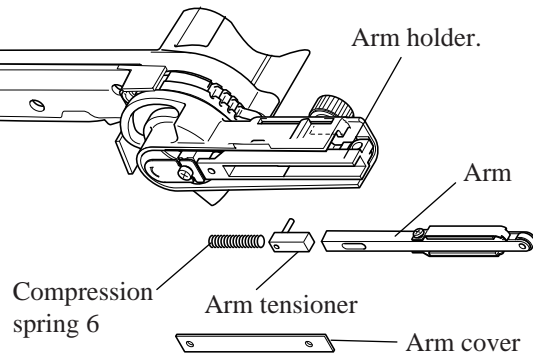

Fig. 4 B

< 5 > Assembling arm section

(1) Set cam lever to lock position by pushing it in the direction of arrow as illustrated in Fig 5.

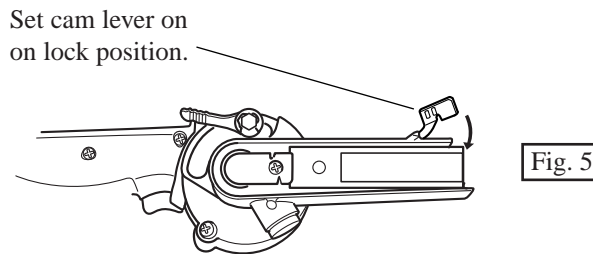

Fig. 5

(2) Assemble arm tensioner and compression spring 6 into arm holder by pressing with arm cover as illustrated in Fig. 5 A.
And slide arm cover with pressing compression spring 6 and arm tensioner, and then, tighten arm cover with hex socket head bolt M4 x 10 as illustrated in Fig. 5 B.

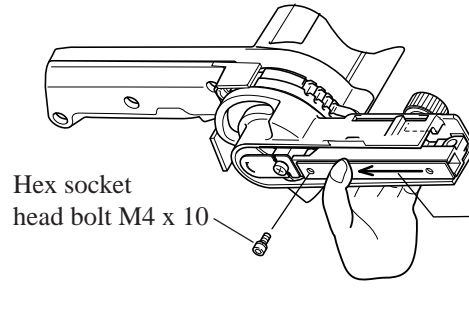
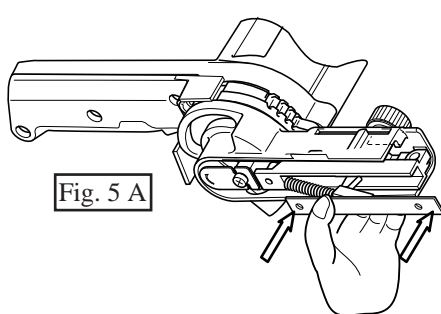

Fig. 5 B

Slide arm cover to align its punched holes with the screw holes of arm holder.

<Note in assembling> Pay attention to the direction of assembling arm cover with referring to the following illustration.



(3) After assembling arm , tighten arm cover with pan head screw M4 x 20 as illustrated in Fig. 5 C.

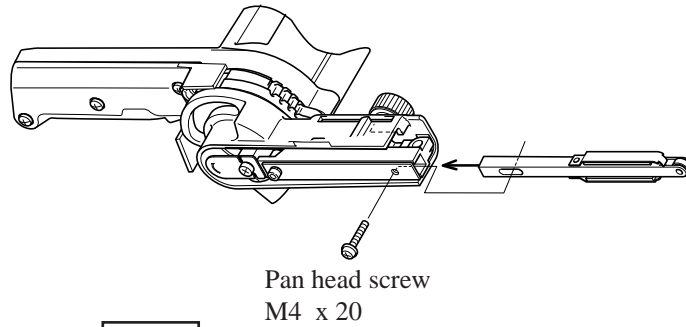

Fig. 5 C

< 6 > Disassembling driving roller and armature

(1) Take off carbon brushes. And disassemble lever 40, hex bolt M5 x 13, flat washer 5 and ring 9 after taking off stop ring E-8. So pulley cover and arm section can be separated from motor unit. See Fig 6.

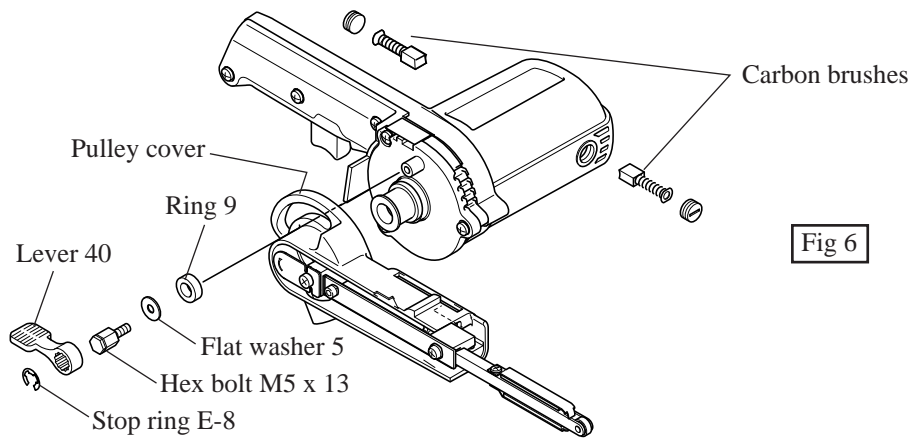

Fig 6

(2) Take off bracket together with armature, by unscrewing tapping screws 4 x 25 as illustrated in Fig. 6 A.

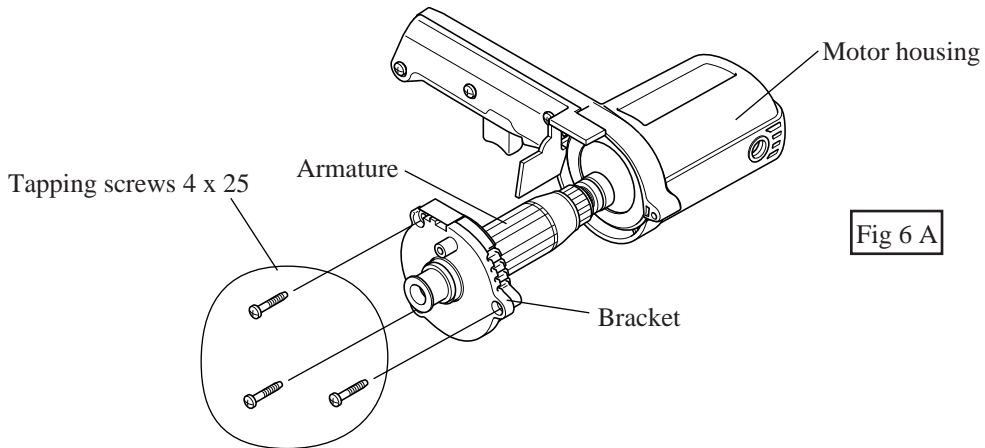

Fig 6 A

(3) Separate driving roller from armature shaft by unscrewing truss head screw M5 x 12 clockwise with an impact driver. See Fig. 6B.

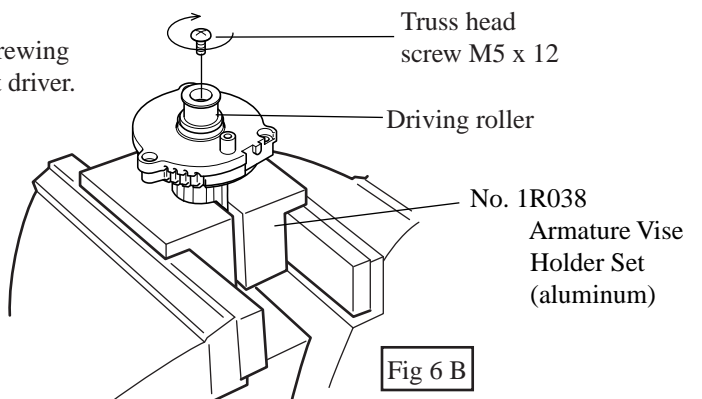
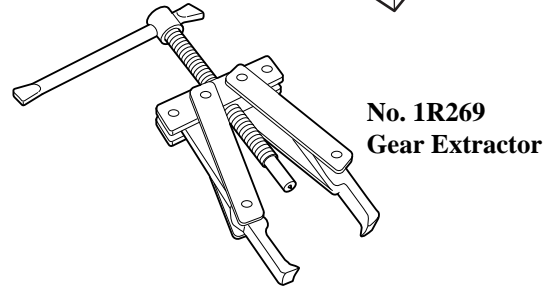
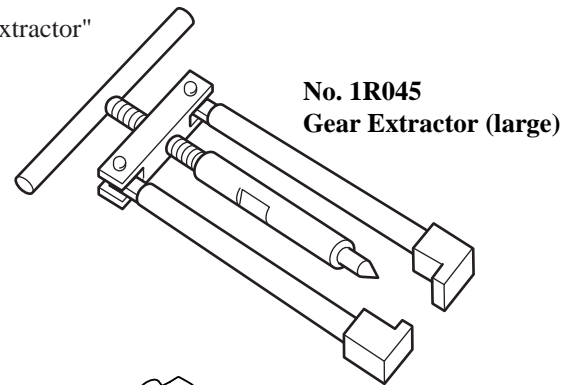
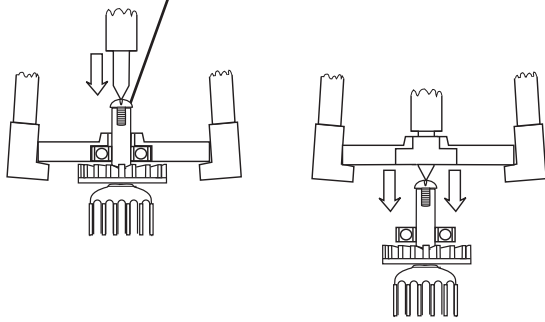

Fig 6 B

- (4) Separate armature from bracket with No.1R045 "large gear extractor"
See Fig. 6 C.

The screw hole of armature shaft is too big for accepting the center bit of bearing extractor. So, screw truss head screw M5 x 12 into armature shaft, for the fitting of center bit on armature shaft.



The both ball bearings of armature can be removed with No.1R269 "gear extractor".

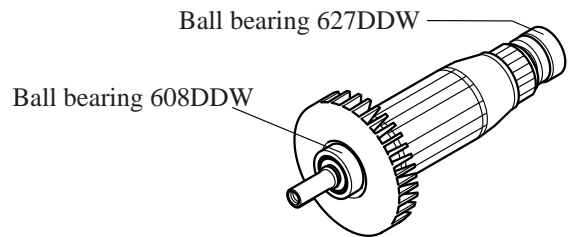

Fig. 6 C

< 7 > Assembling driving roller and armature

- (1) Assemble ball bearing 608DDW to the armature shaft of fan side, and assemble insulation washer and ball bearing 627DDW to the armature shaft of commutator side by pressing with arbor press. as illustrated in Fig. 7.

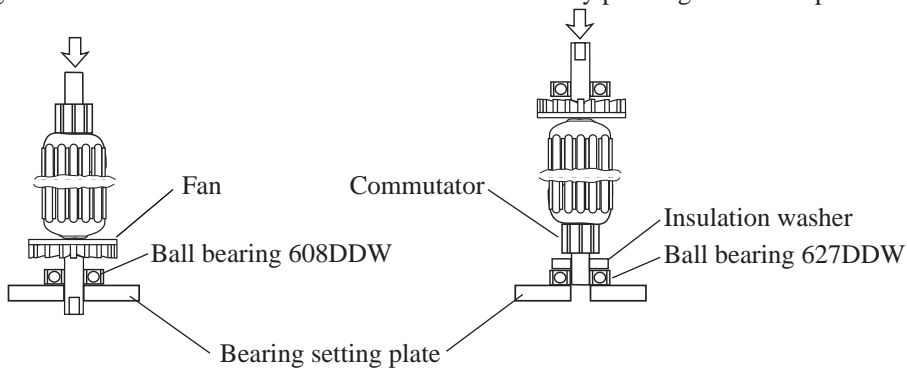

Fig. 7

- (2) Assemble the above armature to bracket by pressing with arbor press. And fasten driving roller with truss head screw M5 x 12. Turn truss head screw M5 x 12 anti-clockwise.

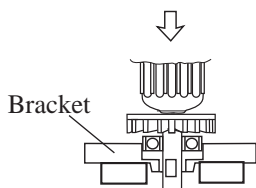

Fig. 7 A

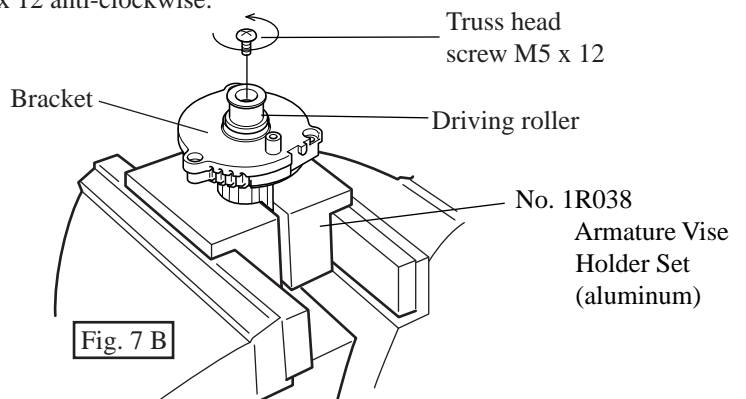
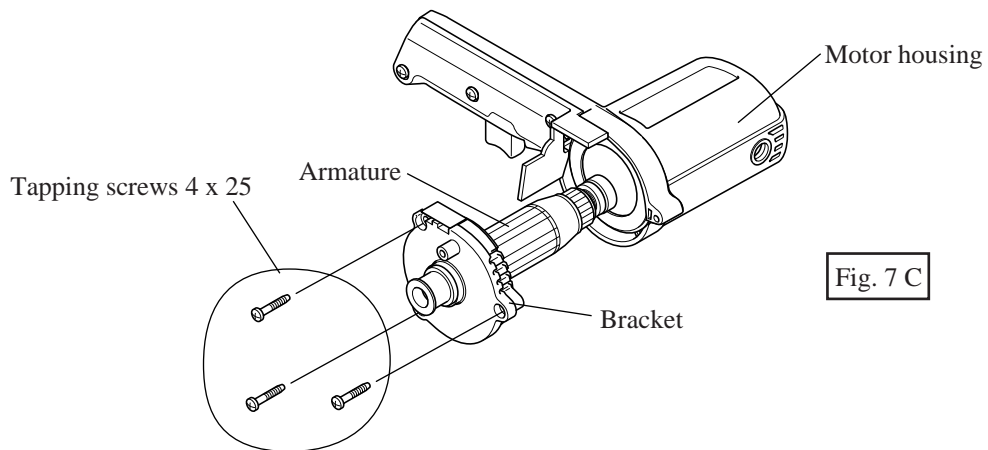

Fig. 7 B

(3) Assemble the bracket to which armature has been assembled, to motor housing as illustrated in Fig. 7 C.



< 8 > Disassembling switch, controller and power supply cord

(1) Take off tapping screws 4 x 18, and inserting -screwdriver, separate handle cover from motor housing.
So, switch, controller, choke coil and power supply cord can be disassembled.
See Fig. 8 and 8 A.

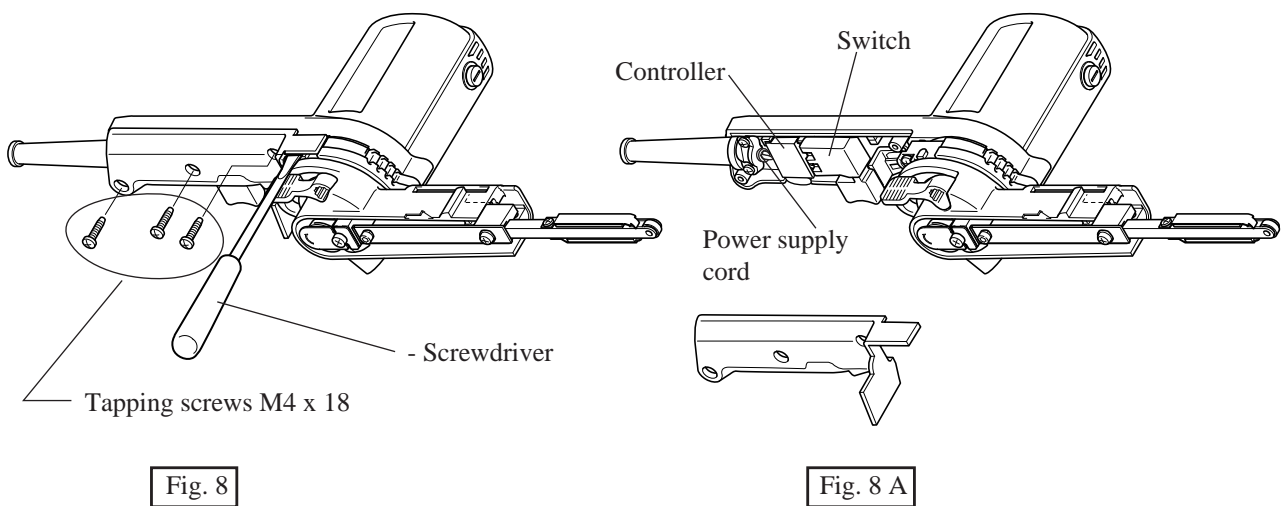

< 9 > Adjusting lever 40

The pivoting area of lever 40 has to be adjusted as illustrated in Fig. 9.

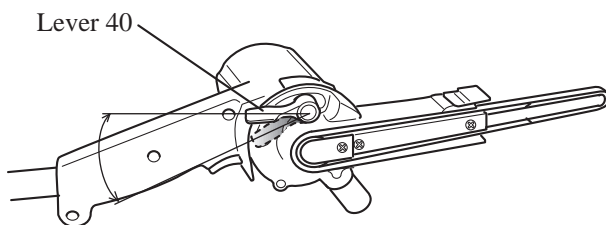



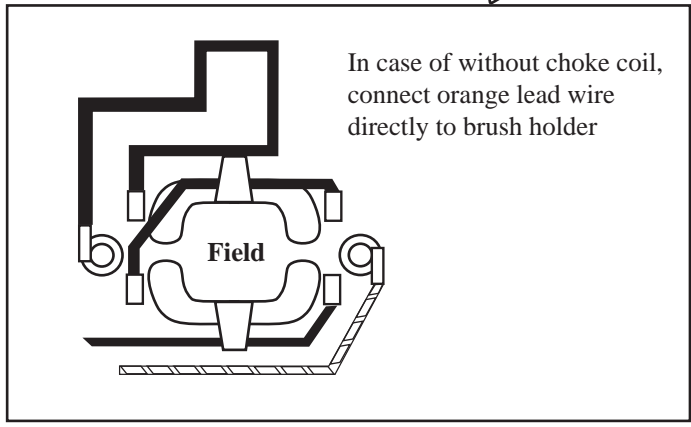
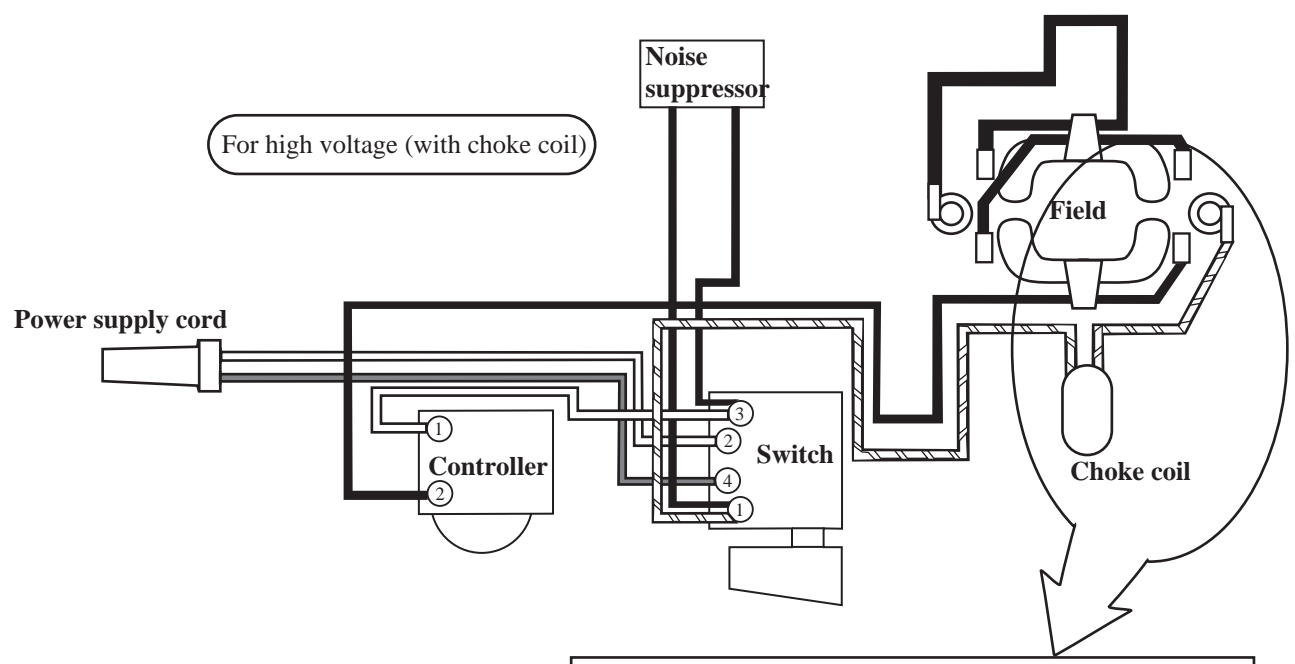
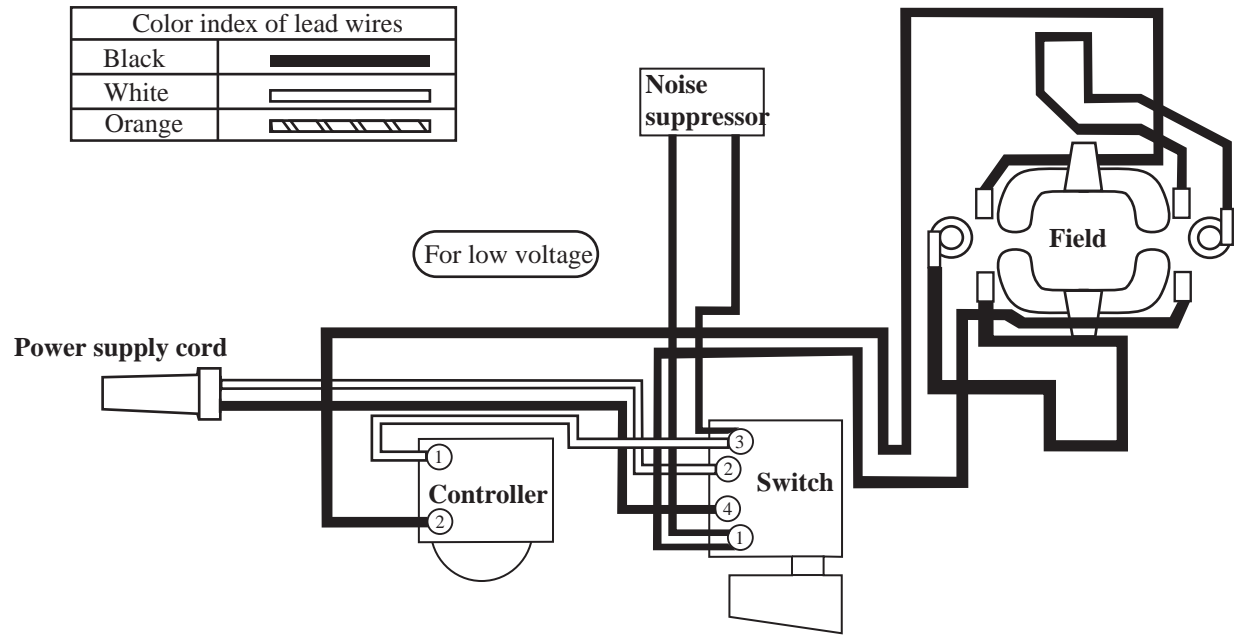

Fig. 9

► **Circuit diagram**

| Color index of lead wires | |
|---------------------------|---|
| Black |  |
| White |  |
| Orange |  |



Pass the lead wires of power supply cords and the same ones of controller, through the space of another side of control dial as illustrated below.

