

TECHNICAL INFORMATION



PRODUCT

P 1 / 29

Model No. ▶ HR2800, HR2810, HR2811F
HR2810T, HR2811FT

Description ▶ Rotary Hammers 28mm (1-1/8")

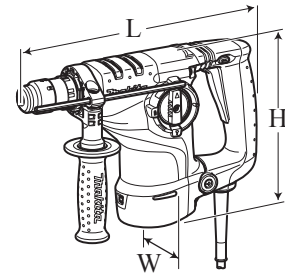

(The image illustrated above is Model HR2811FT.)

CONCEPT AND MAIN APPLICATIONS

HR2800 series models have been developed as SDS-PLUS Rotary hammers positioning between HR2470 and HR3200C series models.

Dimensions: mm (")				
	HR2800 HR2810	HR2811F	HR2810T	HR2811FT
Length (L)	314 (12-3/8)	320 (12-5/8)	339 (13-3/8)	345 (13-5/8)
Width (W)	89 (3-1/2)			
Height (H)	225 (8-7/8)			

► Specification

Voltage (V)	Current (A)	Cycle (Hz)	Continuous Rating (W)		Max. Output (W)
			Input	Output	
110	7.7	50-60	800	400	600
120	7.0	50-60	---	400	600
220	3.8	50-60	800	400	600
230	3.7	50-60	800	400	600
240	3.5	50-60	800	400	600

Rated amperage for North America: 7.0A

Specification		Model	HR2800	HR2810/ HR2811F	HR2810T/ HR2811FT
No load speed: min.= rpm			0 - 1,100		
Impacts per minute: min.= ipm			0 - 4,500		
Shank type			Adapted for SDS-PLUS bits		
Capacities: mm (")	Concrete	TCT bit	28 (1-1/8)		
		Core bit	80 (3-1/8)		
		Diamond core bit	80 (3-1/8)		
	Steel	13 (1/2)			
	Wood	32 (1-1/4)			
Quick change drill chuck			No	Yes	
Operation mode			2 modes (Rotation only/ Rotation with Hammering)	3 modes (Rotation only/ Rotation with Hammering/ Hammering only)	
Vibration absorbing handle			No	No/ Yes	No/ Yes
LED Job light			No	No/ Yes	No/ Yes
Variable speed control			Yes		
Rotation reversing facility			Yes		
Double insulation			Yes		
Power supply cord: m (ft)			Europe: 4.0 (13.1), other countries: 2.5 (8.2)		
Net weight: kg (lbs)			3.2 (7.1)	3.2 (7.1)/ 3.3 (7.3)	3.3 (7.3)/ 3.4 (7.5)

► Standard equipment

- Side handle (Bar-shaped) 1
- Depth gauge 1
- Quick change drill chuck 1 (HR2810T, HR2811FT only)
- Plastic carrying case 1

Note: The standard equipment for the tool shown may differ from country to country.

► **Optional accessories**

SDS-PLUS bits	Chuck adapter	Grease vessel (30g hammer grease)
TCT bits (Taper shank)	Drill chuck S13	Bit grease
Taper shank adapter (SDS-PLUS)	Chuck key S13	Depth gauge
Cotter	SDS-PLUS hammer chuck set	Blow out bulb
Core bits	Scraper assembl	Safety goggle
Center bits	Dust cup 5	Bull points
Rod	Dust cup 9	Cold chisels
Core bit adapter (SDS-PLUS)	Dust extractor attachment	Scaling chisels
	Joint 25	Grooving chisels
	Hosey	Hammer service kit

► Repair

CAUTION: Remove the bit from the machine for safety before repair/ maintenance in accordance with the instruction manual!

[1] NECESSARY REPAIRING TOOLS

Code No.	Description	Use for
1R003	Retaining ring S pliers ST-2N	Assembling / Disassembling Retaining rings and Ring spring
1R041	Vise plate	Holding Tool holder complete, when disassembling Ring spring 28
1R212	Tip for Retaining ring pliers	Attachment for 1R003
1R164	Ring spring setting tool A	Inserting Oil seal 25 into Barrel complete
1R165	Ring spring setting tool B	Inserting Needle bearing 3012 into Barrel complete
1R232	Pipe 30	Inserting Oil seal 25 into Barrel complete
1R238	Round bar for arbor 9-100	Removing Crank section
1R252	Round bar for arbor 30-100	Removing Oil seal 25 and Needle bearing 3012 from Barrel complete
1R269	Bearing extractor	Removing Ball bearings
1R291	Retaining ring S and R pliers	Removing Retaining rings
331776-1	Piston cylinder	Assembling Ring spring 28 into Tool holder (Reserved for a jig in extra)

[2-1] LUBRICATION

Apply Makita grease R. No.00 to the following portions designated with the black triangle to protect parts and product from unusual abrasion.

Item No.	Description	Portion to lubricate
①	Cap 35	Rip portion
⑪	Barrel complete	Oil seal 25 and Needle bearing 3012
⑳	Steel ball 7	Whole portion
㉓	Oil seal 9	Rip portion
㉕	Sleeve 9	Inside where Impact bolt contacts
㉗	Ring 10	Surface where Cushion ring 13 contacts
㉚	O ring 9	Whole portion
㉞	Pin 6	Whole portion
㉠	O ring 16	Whole portion
㉡	Piston cylinder	Inside where Striker moves. Outside for smooth sliding in Tool holder
㉣	Spiral bevel gear 31	Teeth option
㉩	Cap 35	Rip portion
㉭	Stopper	Inside where Tool holder contacts
㉯	Steel ball 7	Whole portion
㉴	Steel ball 6	Whole portion

Fig. 1

Barrel and Tool Holder Section

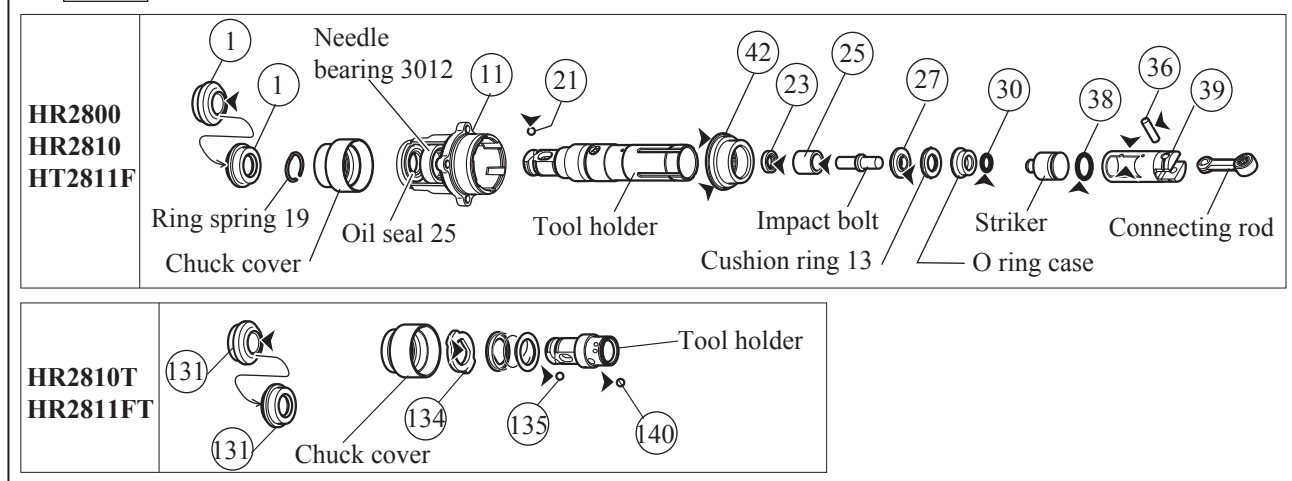

► **Repair**

[2-2] LUBRICATION

Apply Makita grease R. No.00 to the following portions designated with the black triangle to protect parts and product from unusual abrasion.

Item No.	Description	Portion to lubricate
④⑧	O ring 18	Whole portion
⑤⑤	Crank housing complete	Inside Apply approx. 15g Makita grease.
⑦③	Gear housing complete	Its space where Helical gear 29 and Torque limiter engage. Apply approx. 10g Makita grease.
⑦⑤	Oil seal 12	Rip portion

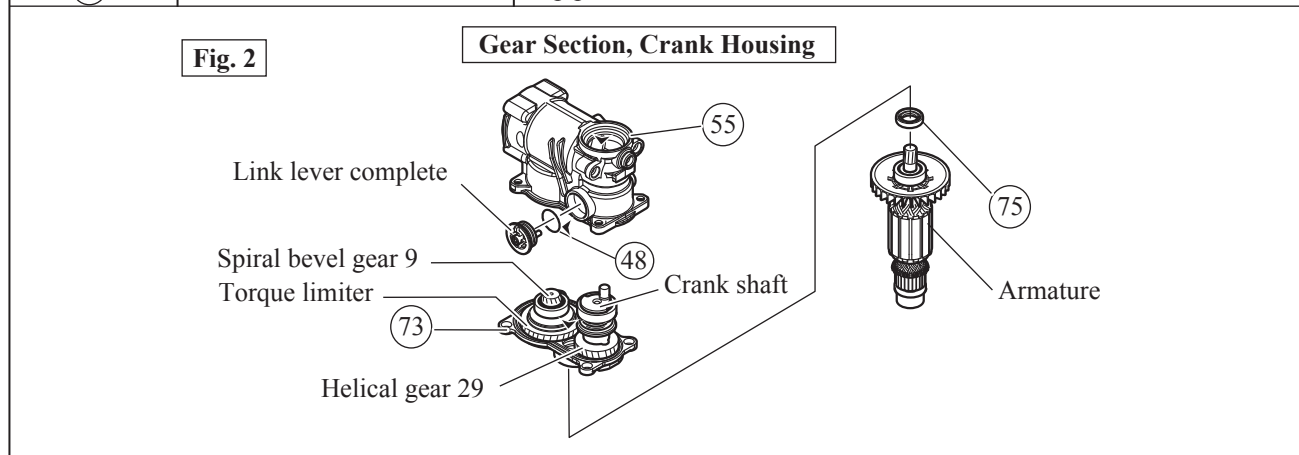

► **Repair**

[3] DISASSEMBLY/ASSEMBLY

[3] -1. Tool Holder Section

DISASSEMBLY

Fig. 3

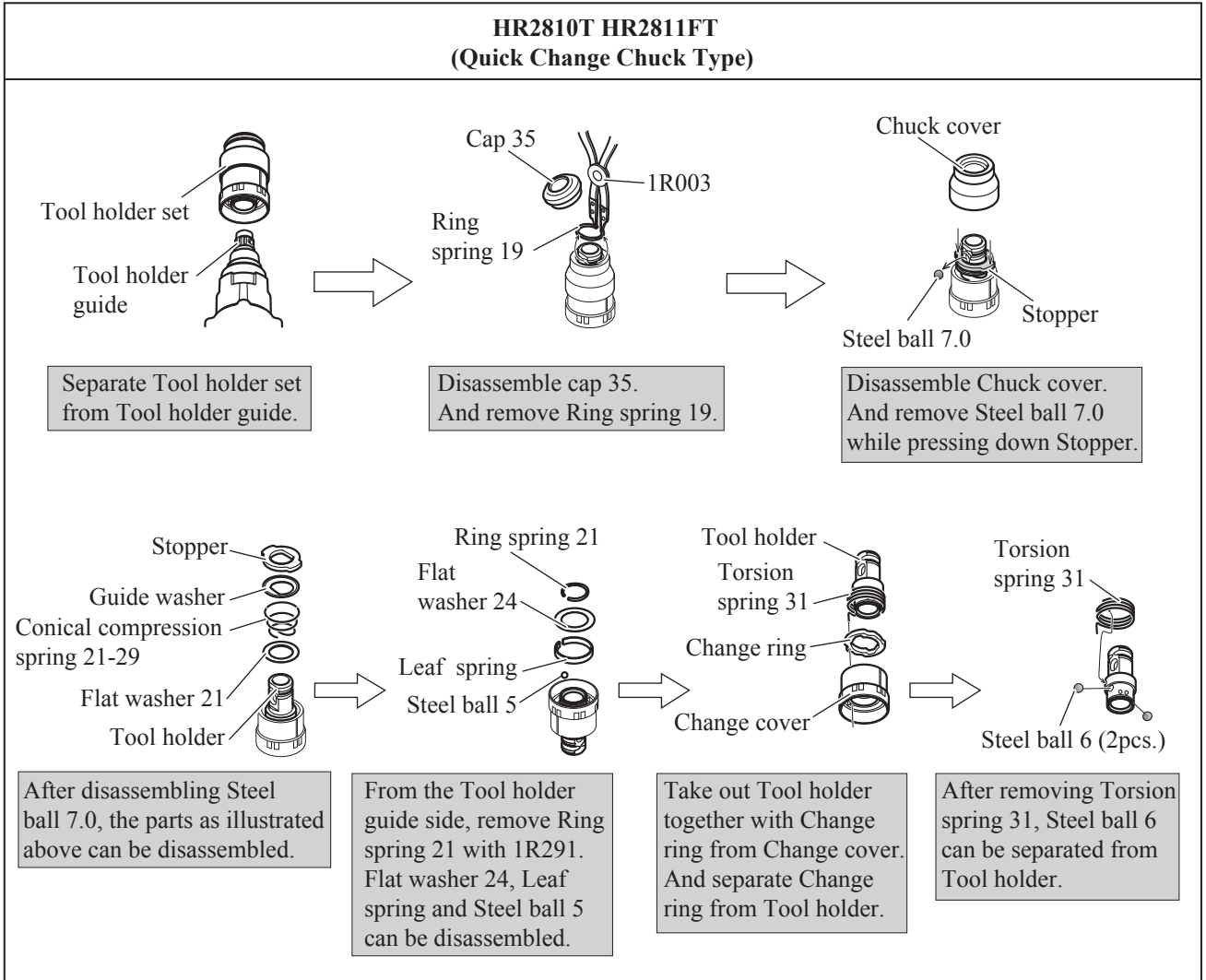
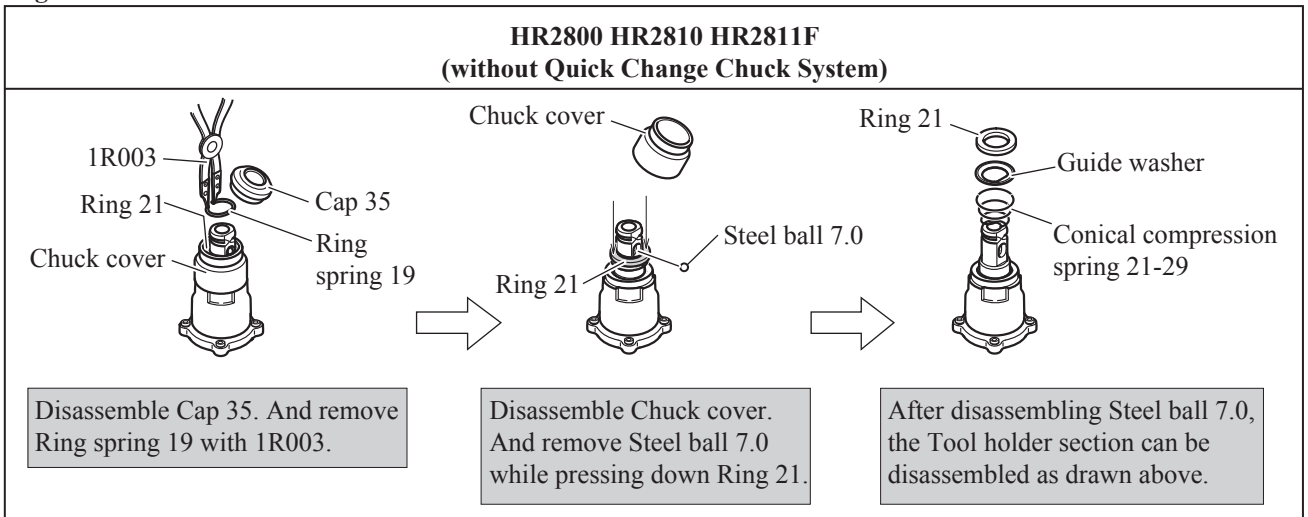

Fig. 4



► Repair

[3] DISASSEMBLY/ASSEMBLY

[3] -1. Tool Holder Section

ASSEMBLY for HR2810T, HR2811FT

- (1) Assemble Change ring to Change cover. (Fig. 5)
- (2) Assemble Torsion spring 31 to Tool holder. (Fig. 6)
- (3) Assemble Tool holder to Change cover. (Fig. 7)

Fig. 5

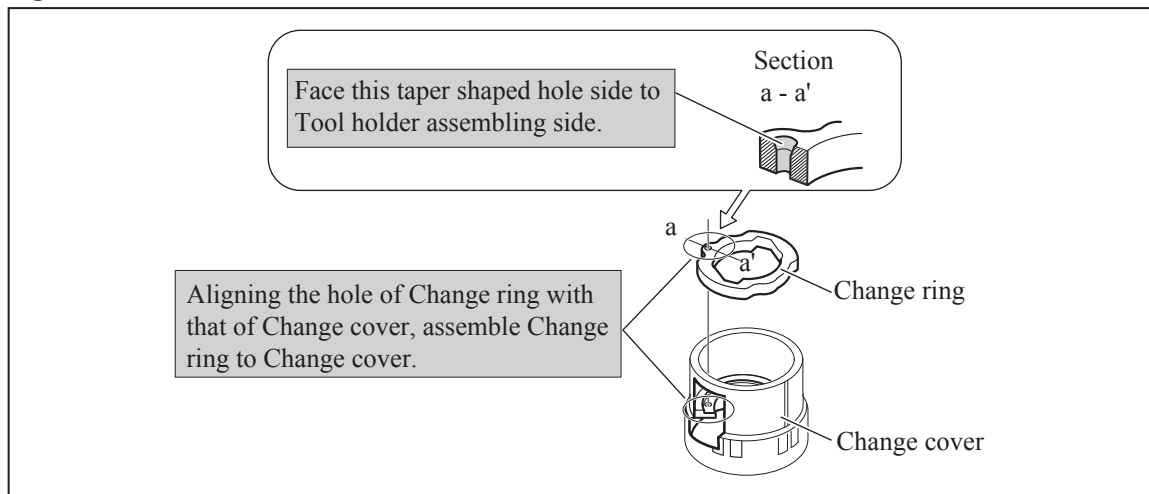

Fig. 6

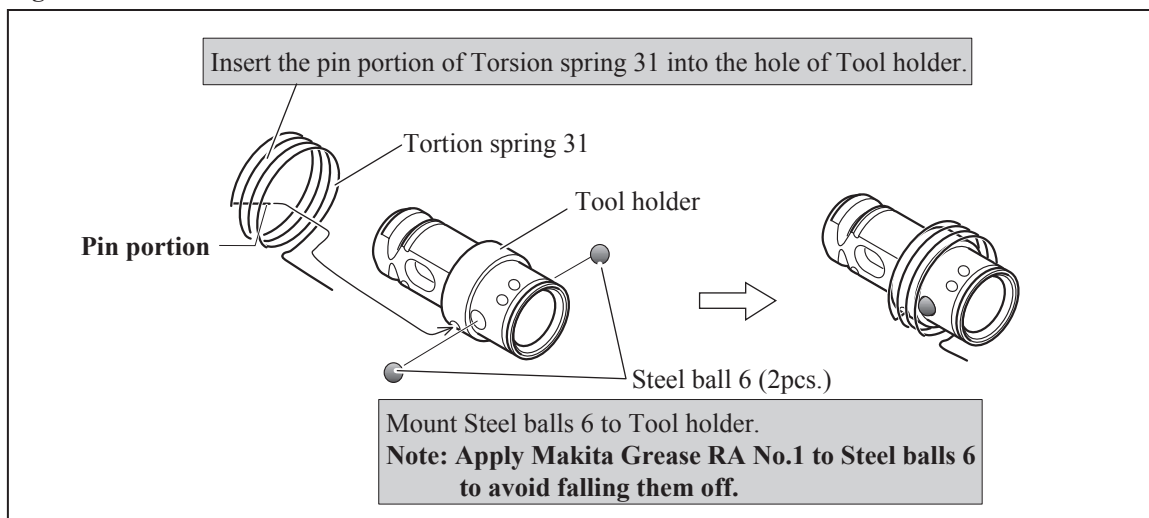
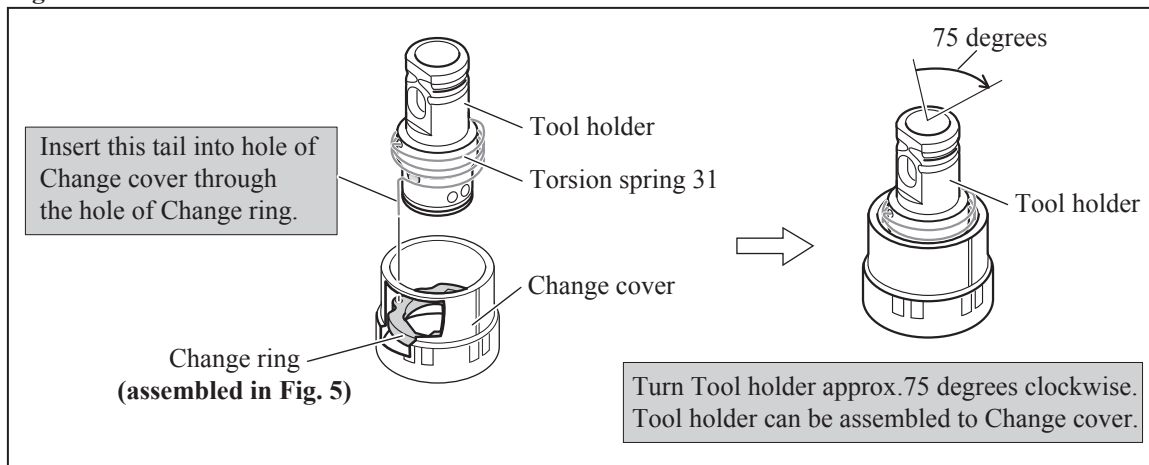

Fig. 7



► **Repair**

[3] DISASSEMBLY/ASSEMBLY

[3] -1. Bit Holder Section

ASSEMBLY for HR2810T, HR2811FT

- (4) Attach Steel ball 5.0 between the ends of Leaf spring, and mount them to the groove between Change lever and Tool holder. **(Fig. 8)**
- (5) Mount Flat washer 24 on Leaf spring, and secure them with Ring spring 21. **(Fig. 8)**
- (6) As for the assembling of Cap 35 side, do the reverse of Disassembling steps. Refer to **Fig. 3**.

ASSEMBLY for HR2800, HR2810, HR2811F

Do the reverse of Disassembling steps. Refer to **Fig. 4**.

Fig. 8

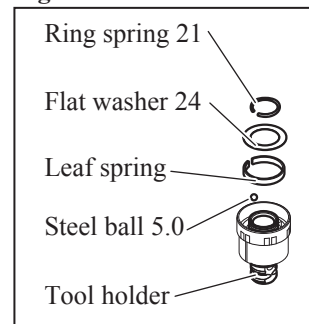

[3] -2. Drill Chuck Assembly (for HR2810T, HR2811FT)

DISASSEMBLY

Drill chuck assembly can be disassembled as drawn in **Fig. 9 - 13**.

Fig. 9

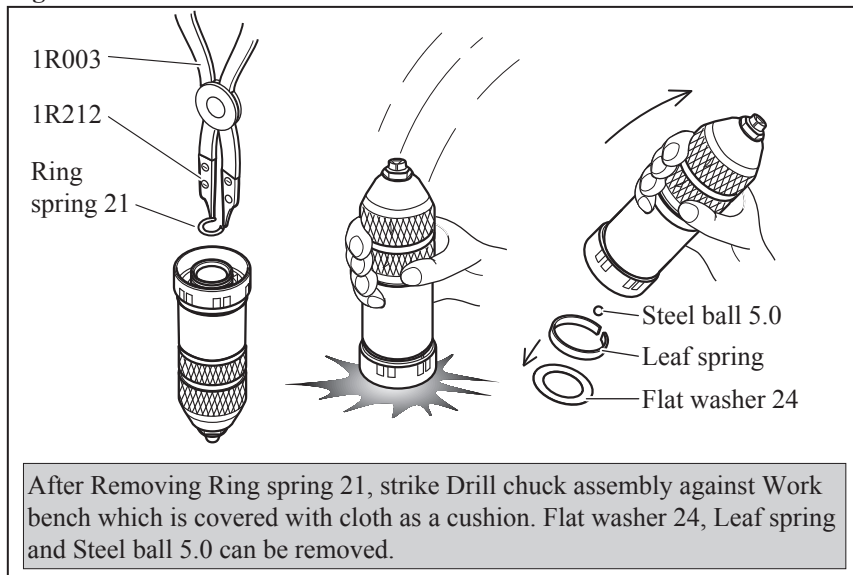

After Removing Ring spring 21, strike Drill chuck assembly against Work bench which is covered with cloth as a cushion. Flat washer 24, Leaf spring and Steel ball 5.0 can be removed.

Fig. 10

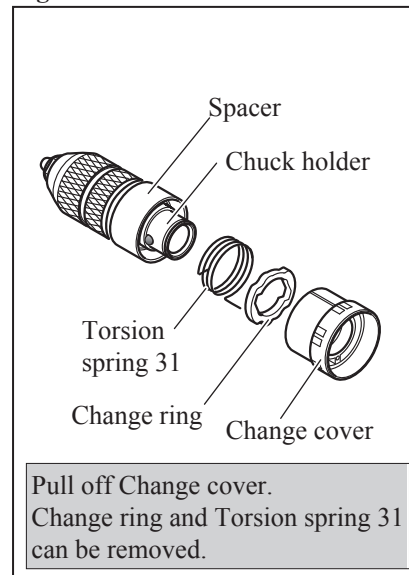

Pull off Change cover. Change ring and Torsion spring 31 can be removed.

Fig. 11

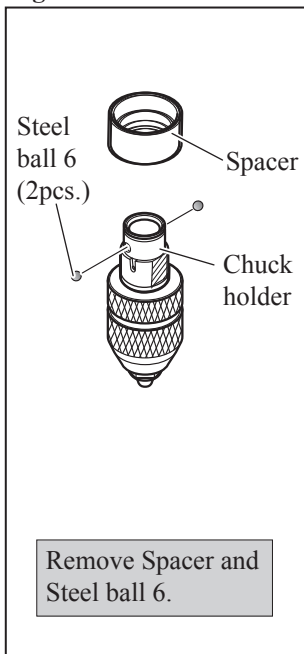

Remove Spacer and Steel ball 6.

Fig. 12

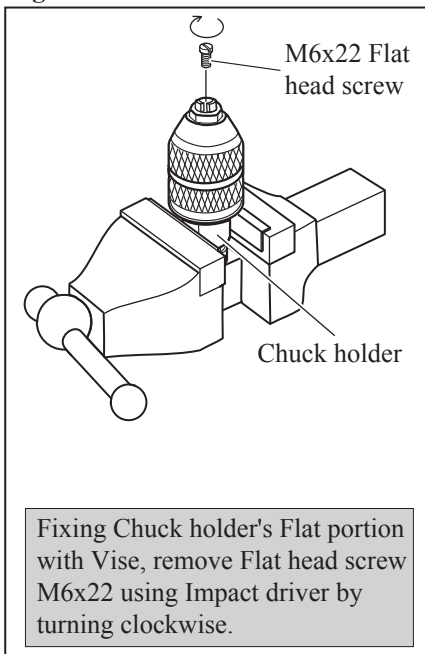

Fixing Chuck holder's Flat portion with Vise, remove Flat head screw M6x22 using Impact driver by turning clockwise.

Fig. 13

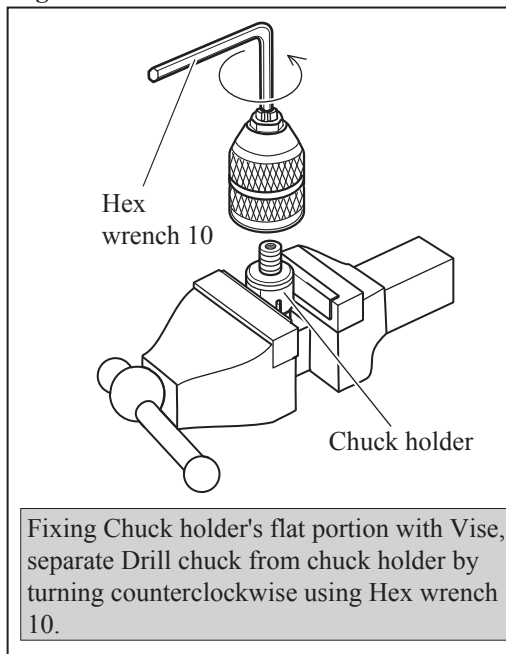

Fixing Chuck holder's flat portion with Vise, separate Drill chuck from chuck holder by turning counterclockwise using Hex wrench 10.

► **Repair**

[3] DISASSEMBLY/ASSEMBLY

[3] -2. Drill Chuck Assembly (for HR2810T, HR2811FT)

ASSEMBLY

- (1) Fixing Chuck holder's Flat portion with Vise, assemble Drill chuck to Chuck holder by turning clockwise using Hex wrench 10. Refer to **Fig. 13**.
- (2) Secure Drill chuck with M6x22 Flat head screw by turning counterclockwise using Impact driver. Refer to **Fig. 12**.
- (3) Assemble Drill chuck to Spacer. (**Fig. 14**) And mount Steel ball 6. (**Fig. 15**)
- (4) Mount Torsion spring 31. And Assemble the Drill chuck to Change cover. (**Fig. 16**)
- (5) Mount Steel ball 5, Leaf spring and Flat washer 24 to Chuck holder. And secure them with Ring spring 21. (**Fig. 17**)

Fig. 14

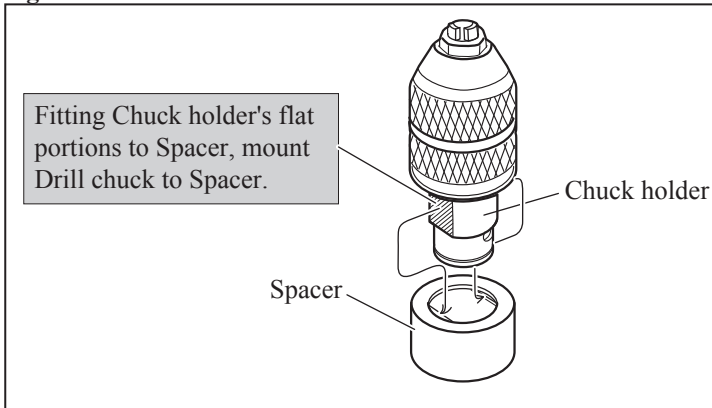

Fig. 15

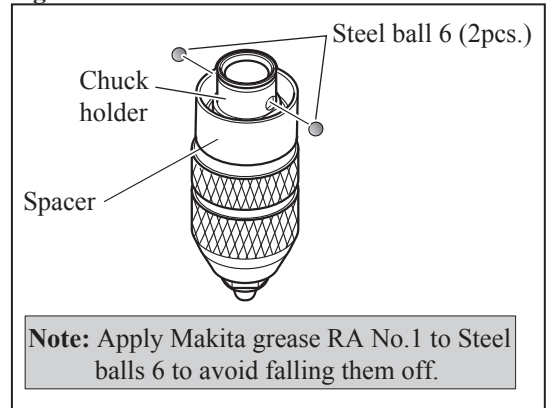

Fig. 16

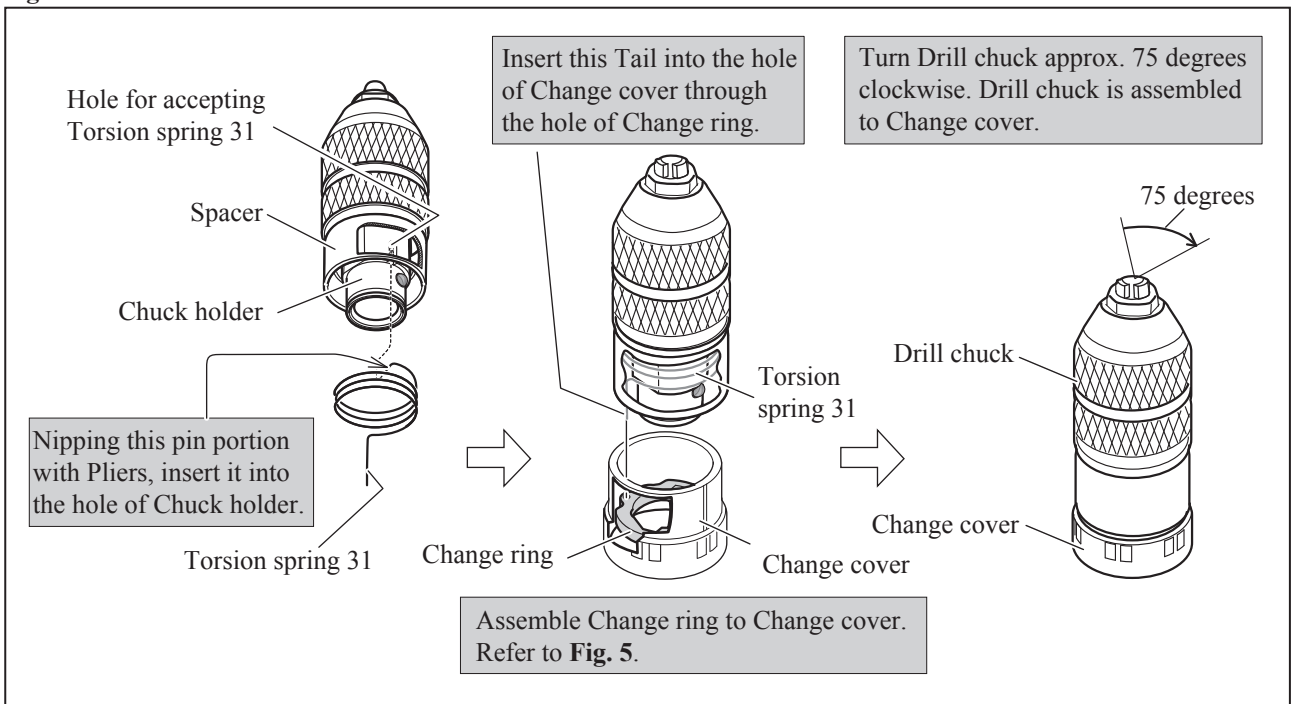
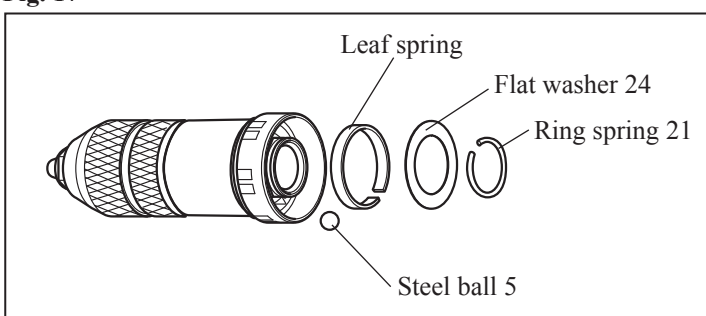

Fig. 17



► **Repair**

[3] DISASSEMBLY/ ASSEMBLY

[3] -3. Handle Section

DISASSEMBLY

- (1) Disassemble Crank housing cover by unscrewing M4x16 Hex socket head bolt. (**Figs. 18 and 18A**)
- (2) Two mode type is different from Three mode type in the way to remove Change lever complete.

For **Two mode type**, do the step of **Figs. 18 and 19**. For **Three mode type**, do the step of **Figs. 18A and 19A**.

Fig.18

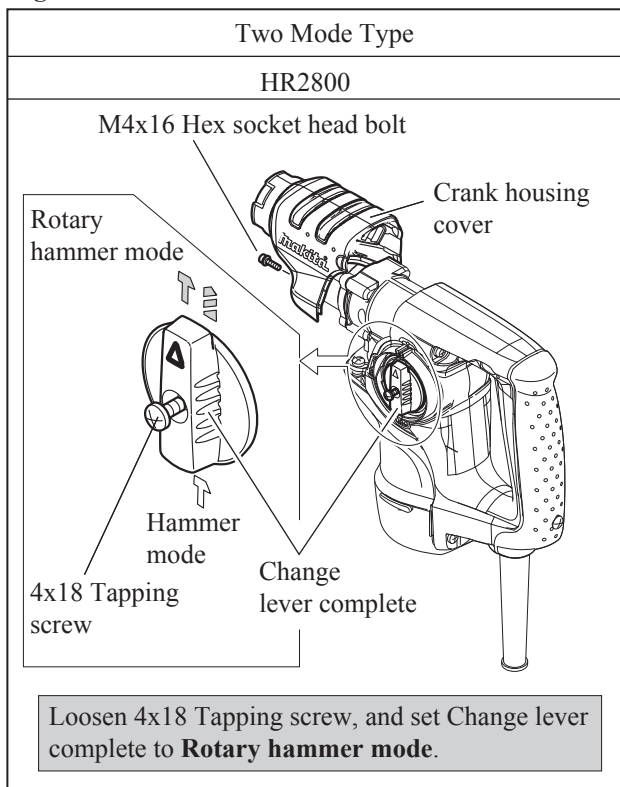

Fig.18A

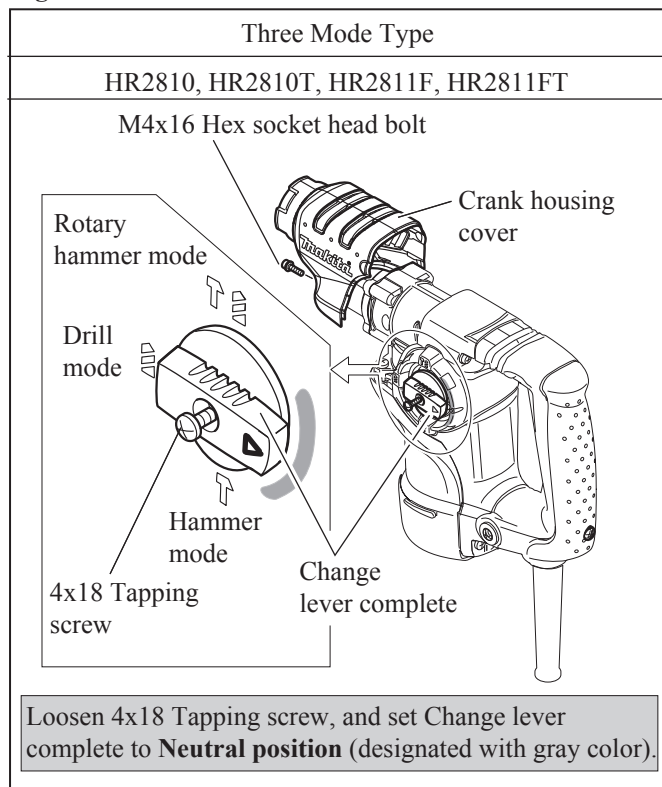

Fig.19

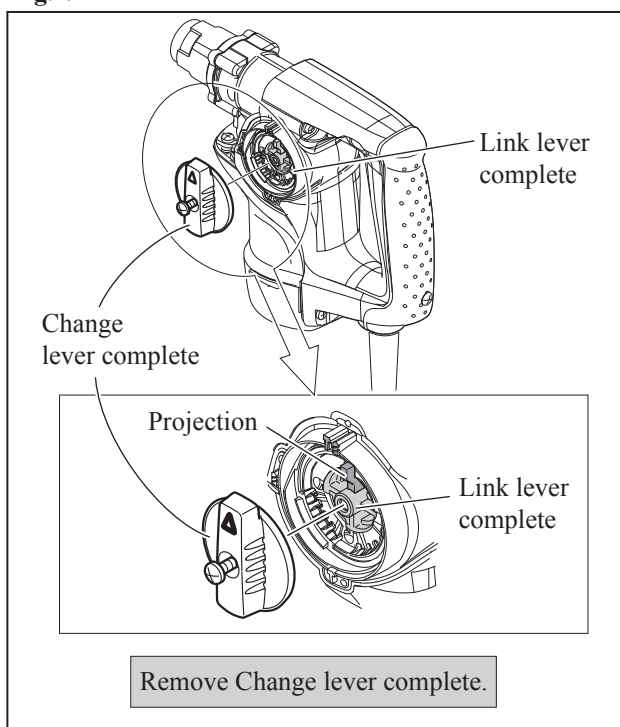
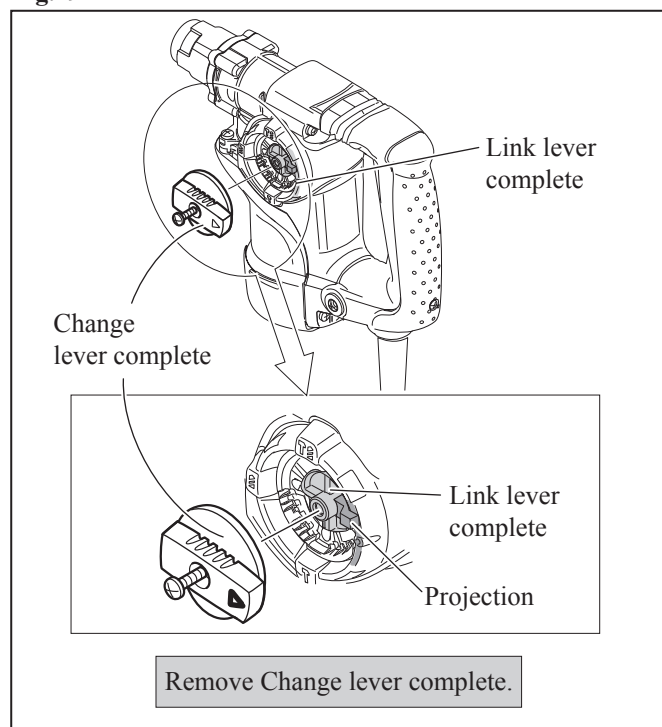

Fig.19A



► **Repair**

[3] DISASSEMBLY/ASSEMBLY

[3] -3. Handle Section

DISASSEMBLY

(3) Now Handle section can be separated from the Machine in the order of **Figs. 20, 21 and 22.**

Note: Change lever assembling hole of Handle (Handle base) is blocked by the projection of Link lever complete.
It is recommended to use two slotted-Screwdrivers. (Fig. 21)

Fig.20

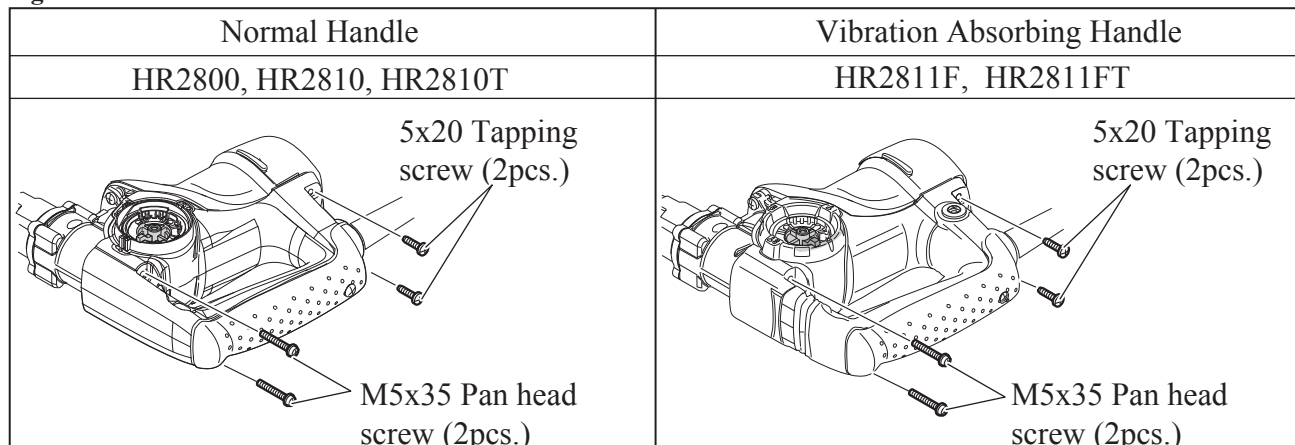

Fig.21

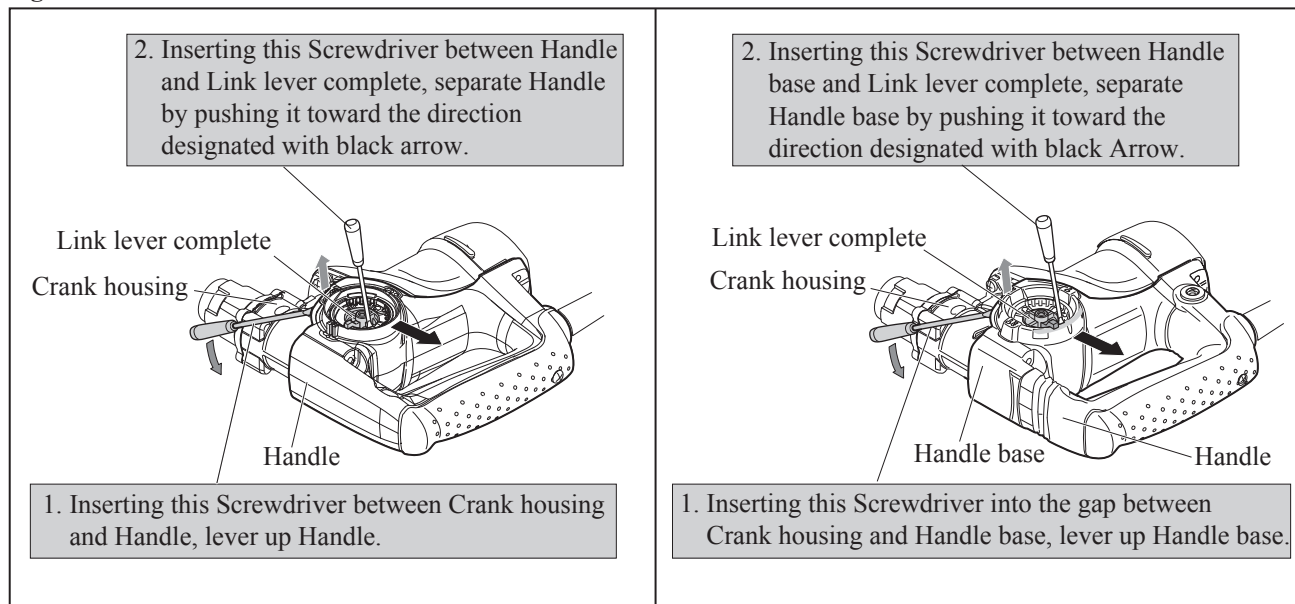
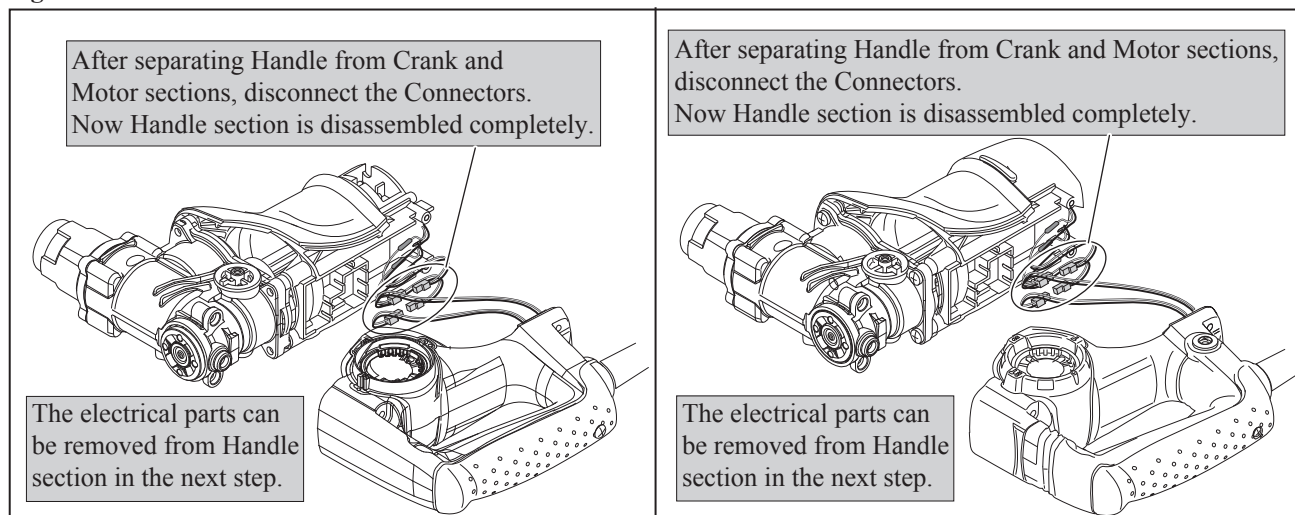

Fig.22



► Repair

[3] DISASSEMBLY/ ASSEMBLY

[3] -3. Handle Section

DISASSEMBLY

- (4) Disassemble Handle cover by unscrewing 4x18 Tapping screw. Now the electrical parts can be replaced as drawn in Fig. 23.

Fig.23

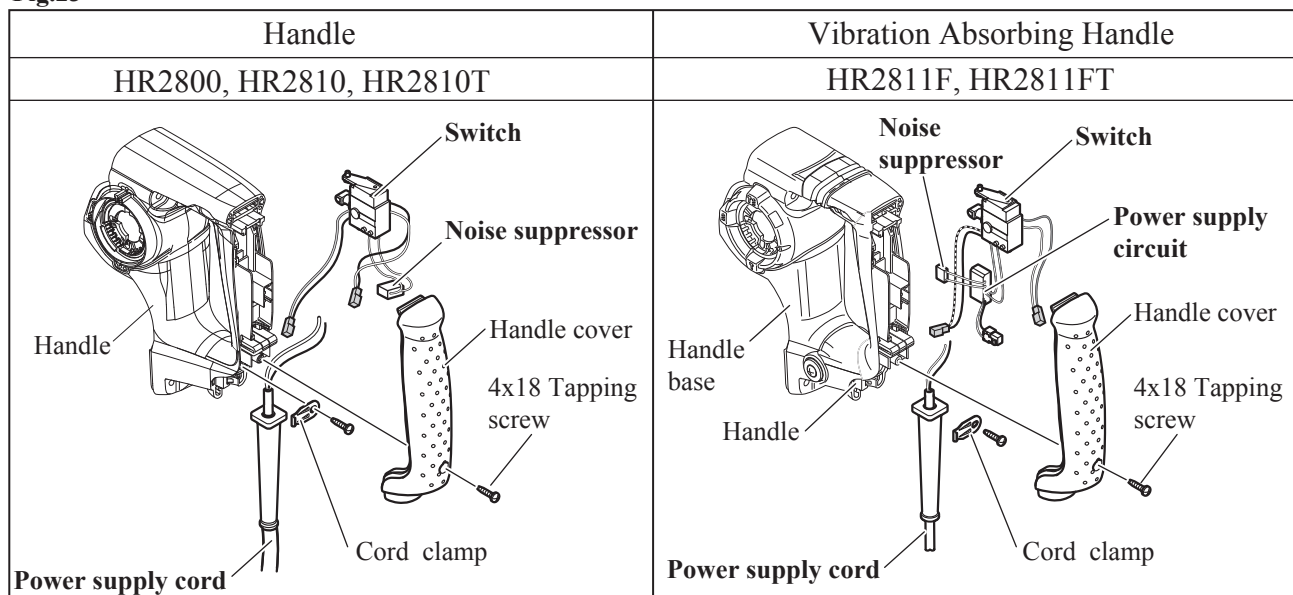

ASSEMBLY

- (1) Set the electrical parts in place, and guide their Lead wires of Connectors side to the Motor housing side of Handle (Handle base), in order to connect them with the Connectors of Lead wires from Motor housing. And secure Handle cover to Handle with Tapping screw 4x18. Refer to **Figs. 23 and 22**.
- (2) Connect the Connectors of the replaced electrical parts with those of Lead wires from Motor housing. Refer to **Fig. 22**.
- (3) Assemble the Handle section to the Machine. Refer to **Figs. 21 and 20**.
- (4) Assemble Change lever to Link lever complete. Refer to **Figs. 19 and 19A**.

► **Repair**

[3] DISASSEMBLY/ ASSEMBLY

[3] -4. Motor Section

DISASSEMBLY

- (1) Remove Crank housing cover and Handle section from the Machine. (Fig. 18 / Fig. 18A, Fig. 19 / Fig. 19A, Fig. 20, Fig. 21, Fig. 22)
- (2) Disassemble Armature as drawn in Figs. 24 and 25.

Fig.24

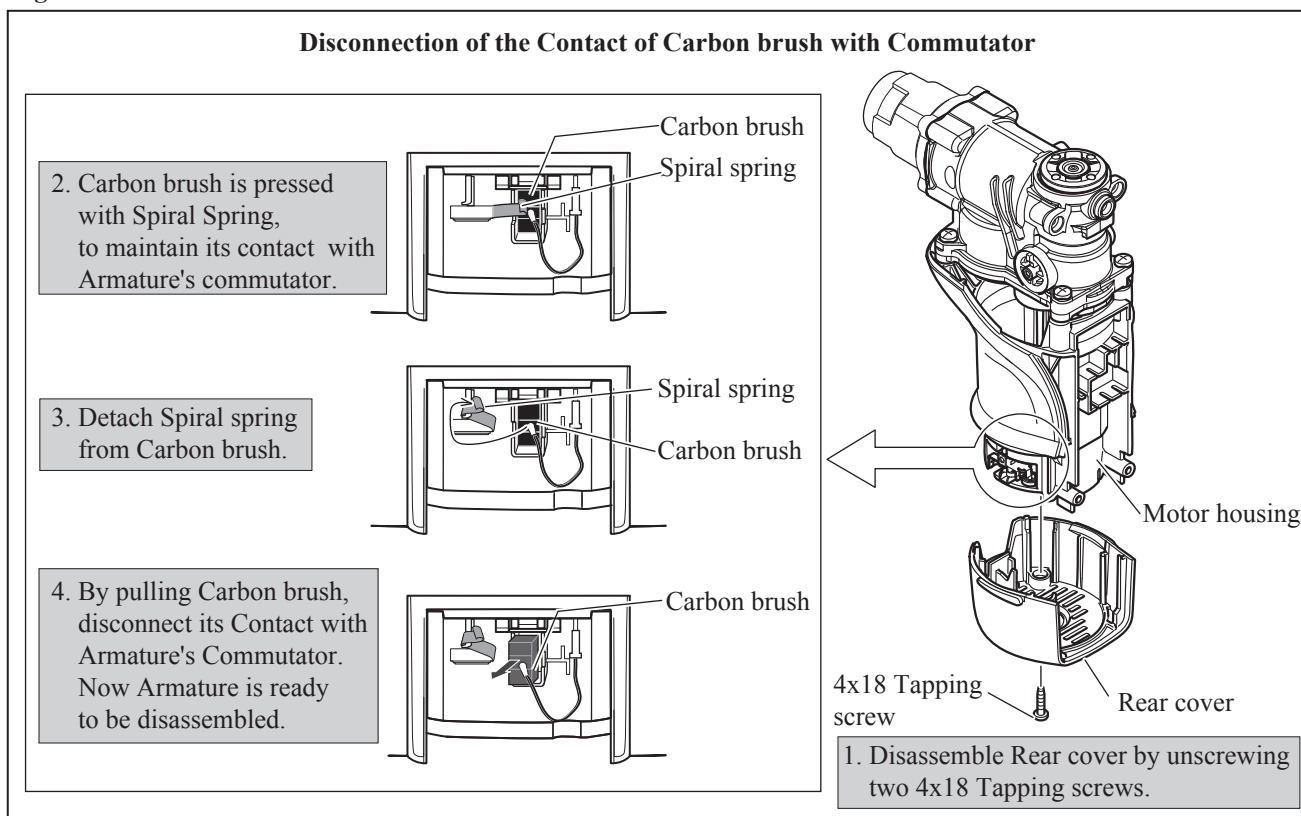
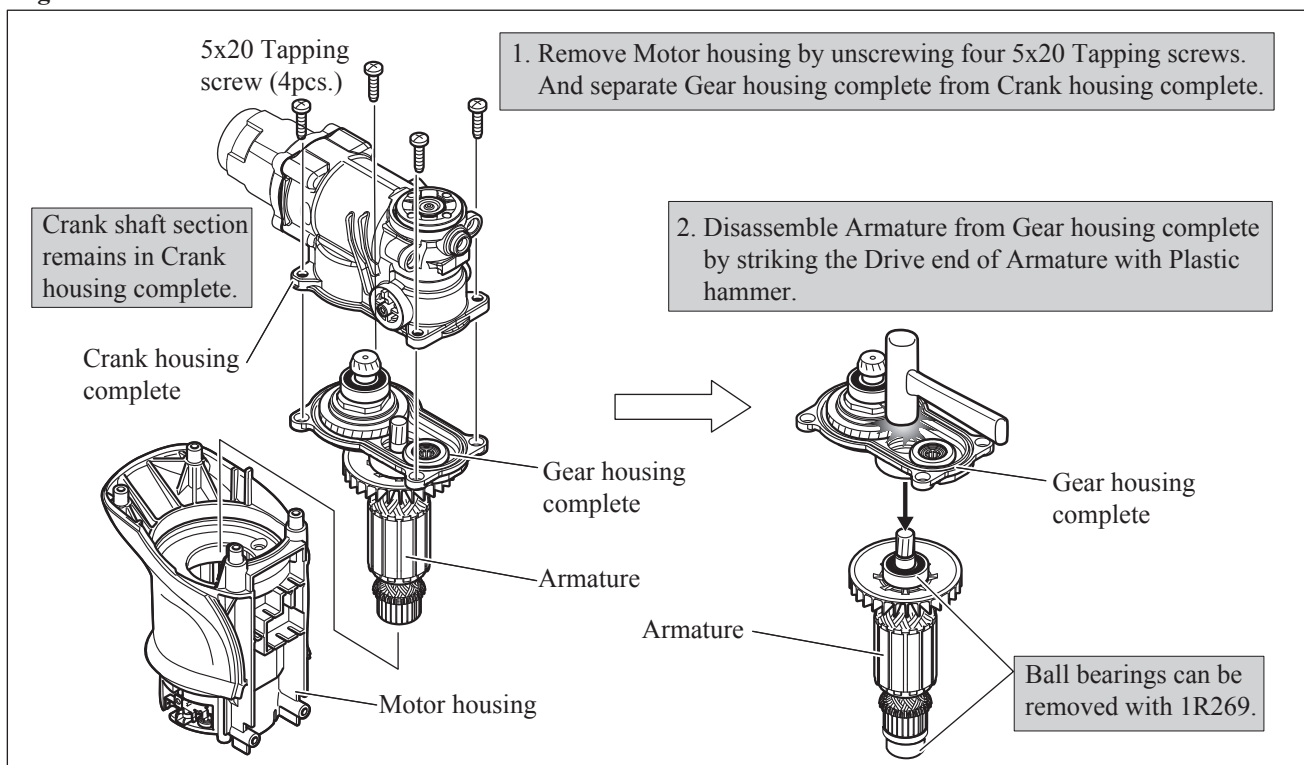

Fig.25



► Repair

[3] DISASSEMBLY/ ASSEMBLY

[3] -4. Motor Section

ASSEMBLY

Do the reverse of disassembling steps. Refer to **Figs. 24 and 25.**

Note: • When mounting new Ball bearings to Armature, do not forget to mount Flat washer 10, Sleeve 10 and Insulation washer to Armature. (Fig. 26)

• After assembling Armature to Gear housing complete, do not forget to mount Seal ring and Cup washer 16 to Crank shaft accepting hole. (Fig. 27)

Fig. 26

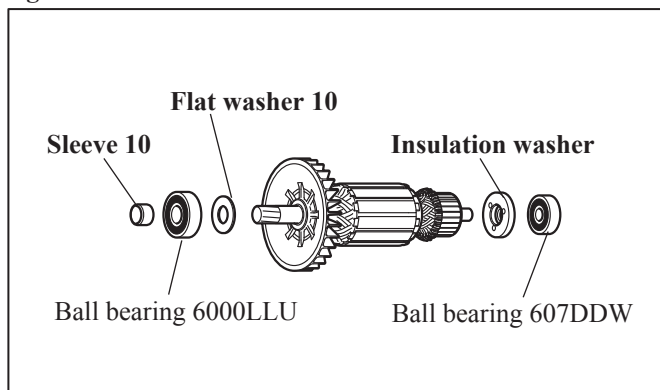
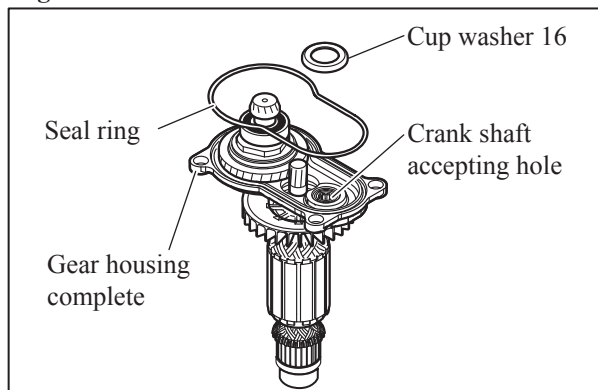

Fig. 27



[3] -5. Crank Housing

(1) Disassemble Tool holder section from the Machine.

(Fig. 3 for HR2810T and HR2811FT / Fig.4 for HR2800, HR2810 and HR2811F)

(2) Disassemble Handle section from the Machine.

(Fig.18 / Fig.18A, Fig.19 / Fig.19A, Fig.20, Fig.21, Fig.22)

(3) Separate Crank housing complete from Motor housing. (Figs. 24 and 25)

(4) Disassemble Barrel complete and Tool holder complete from Crank housing complete. (Fig. 28)

(5) Remove Crank cap and Link lever complete from Crank housing complete. (Fig. 29)

And Separate Gear housing complete from Crank housing complete. Torque limiter section can be removed. (Fig. 29)

Fig. 28

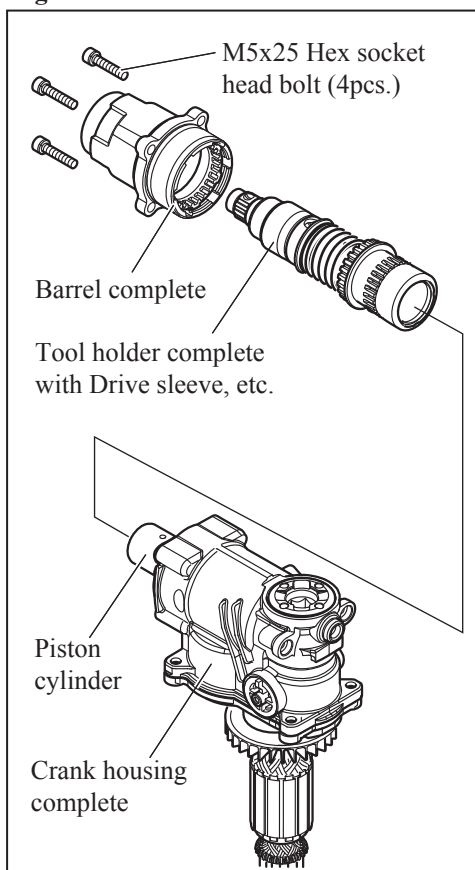
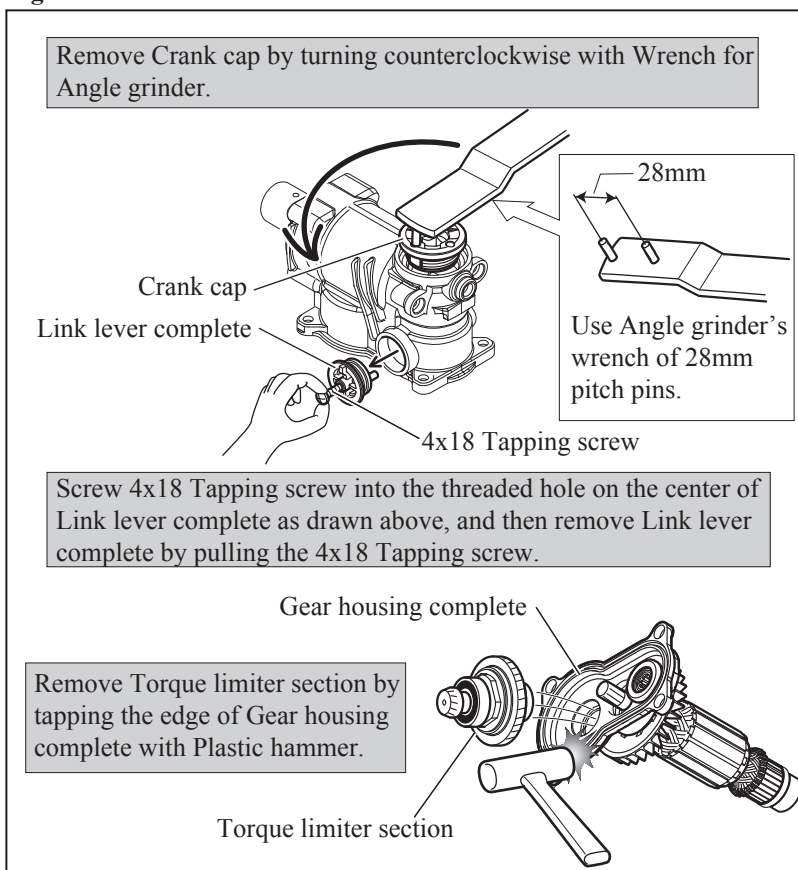

Fig. 29



► **Repair**

[3] DISASSEMBLY/ASSEMBLY

[3] -5. Crank Housing

DISASSEMBLY

(6) Disassemble Link plate section, Spiral bevel gear 31, Piston cylinder, Striker and O ring 16, from Crank housing complete. (Figs. 30, 31, 32, and 33)

In case of HR2800 (2 Mode type), you can skip the Step of Fig. 30.

Fig. 30

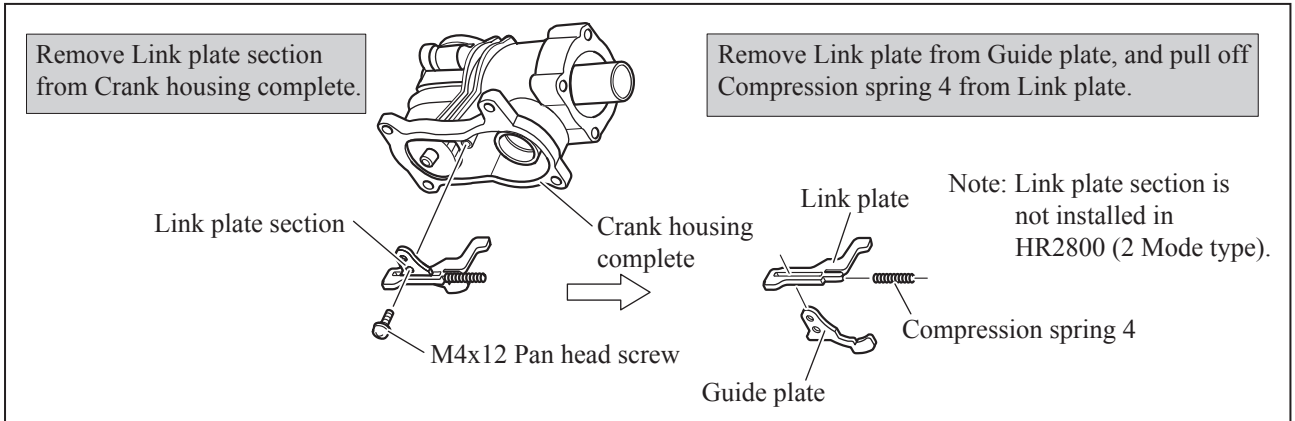

Fig. 31

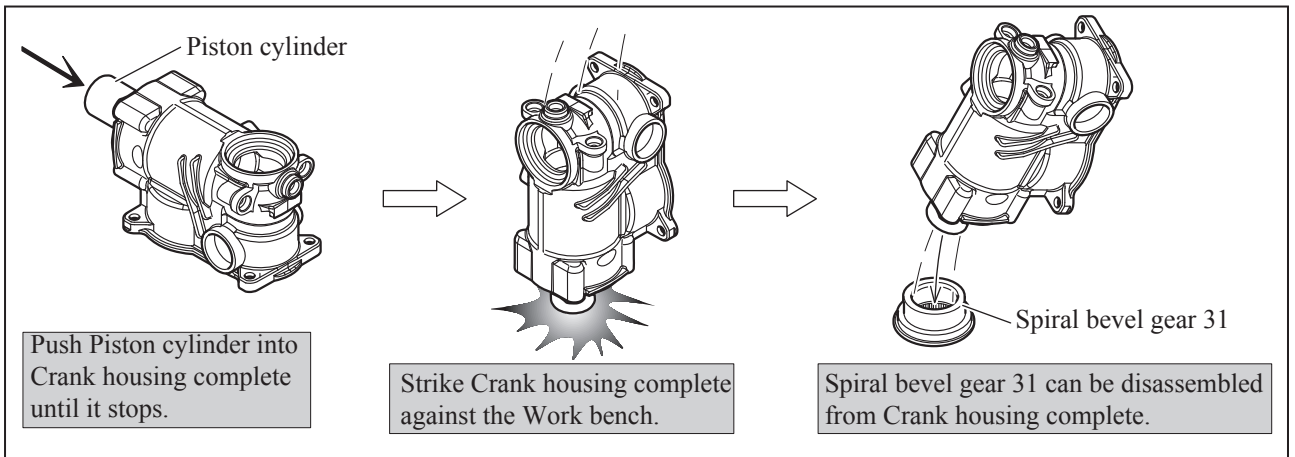

Fig. 32

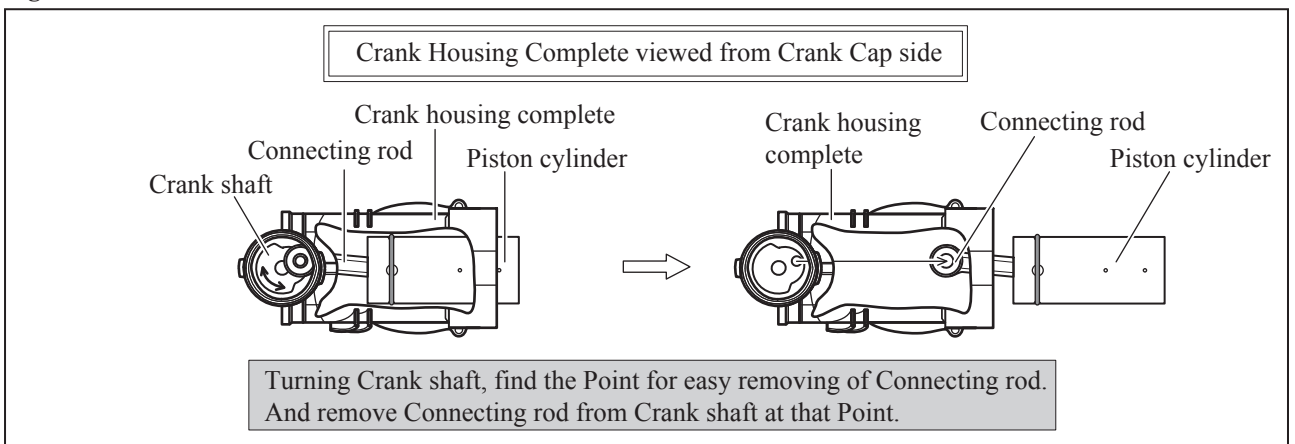
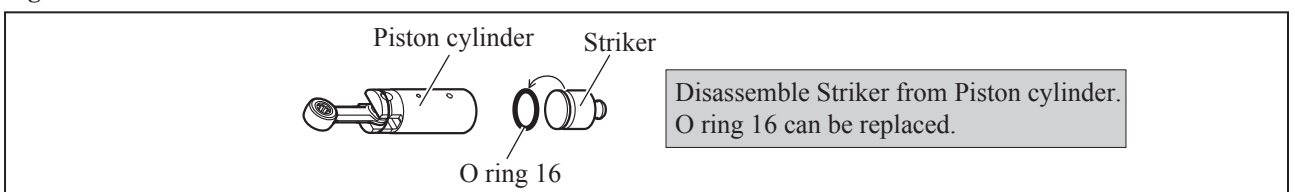

Fig. 33



► **Repair**

[3] DISASSEMBLY/ASSEMBLY

[3] -5. Crank Housing

ASSEMBLY

- (1) Mount new O ring 16 to Striker, and insert Striker to Piston cylinder. Refer to **Fig. 33**.
 - (2) Assemble Piston cylinder to Crank housing complete, and connect Connecting rod with Crank shaft. Refer to **Fig. 32**.
 - (3) Assemble Spiral bevel gear 31 to Crank housing complete. (**Fig. 34**)
 - (4) Assemble the Link plate section by mounting Guide plate and Compression spring 4 to Link plate.
Secure the assembled Link plate section to Crank housing complete with M4x12 Pan head screw. (Refer to **Fig. 30**)
- Note:** In case of HR2800 (Two Mode type), you can skip this step because Link plate section is not installed in HR2800.
- (5) Mount Torque limiter section, Cup washer 16 and Seal ring to Gear housing complete. Refer to **Fig. 27**.
 - (6) Assemble Link lever complete to Crank housing complete. (**Fig. 35**)
 - (7) Do the reverse of Disassembling Steps. Refer to **Figs. 28 and 29**.

Fig. 34

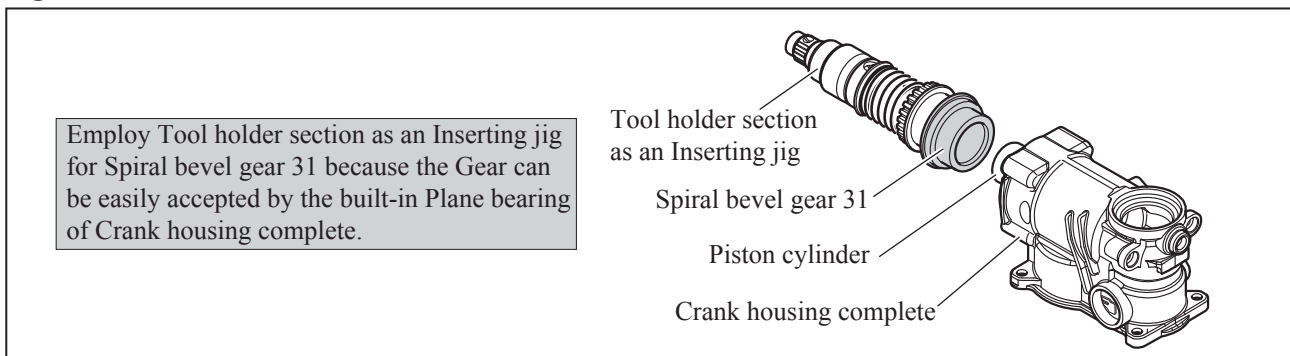
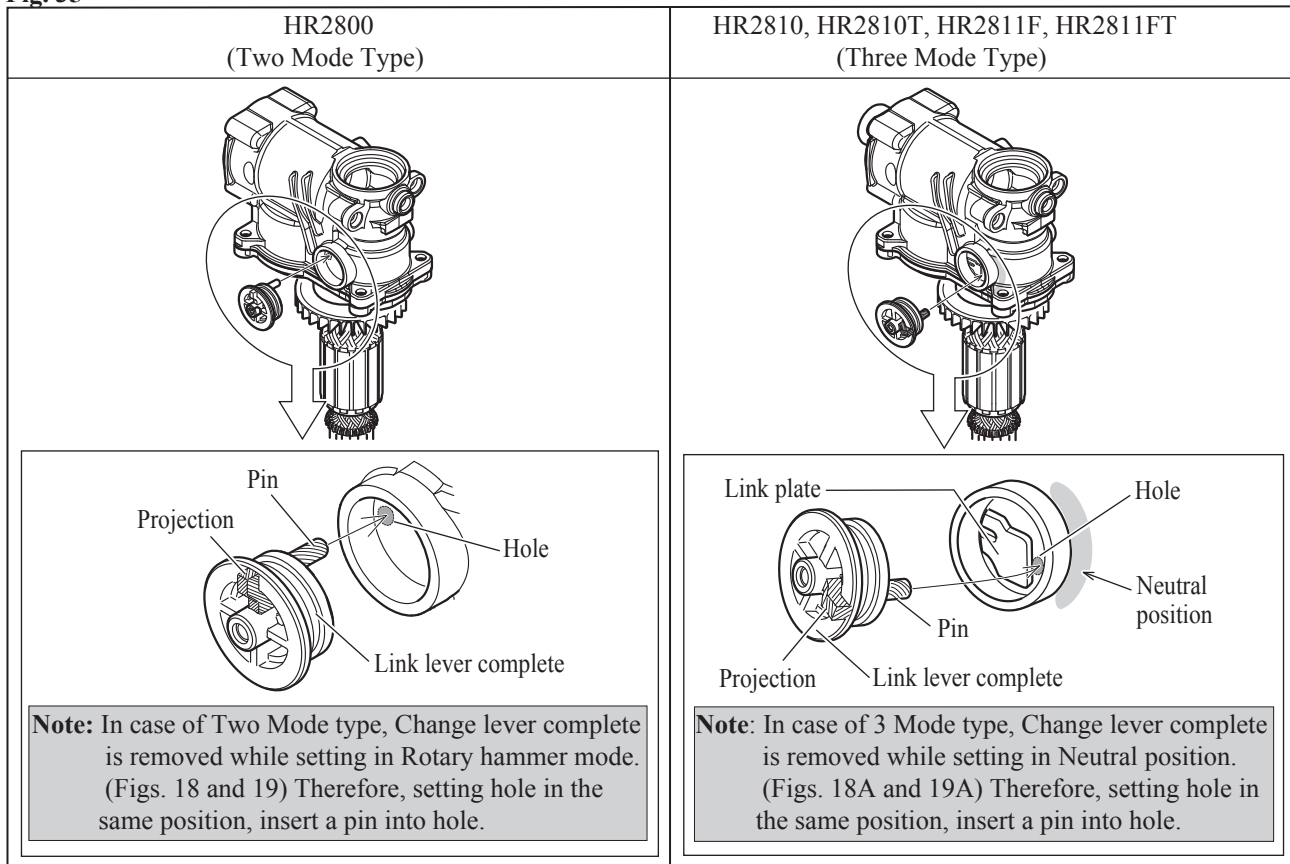

Fig. 35



► Repair

[3] DISASSEMBLY/ASSEMBLY

[3] -6. Torque Limier Section

DISASSEMBLY

- (1) Remove Crank housing cover and Handle section from the Machine. (**Fig. 18 / Fig. 18A, Fig. 19 / Fig. 19A, Fig. 20, Fig. 21, Fig. 22**)
- (2) Disassemble Gear housing complete from Crank housing complete (**Figs. 24 and 25**)
- (3) Remove Torque limiter section from Gear housing complete. (**Fig. 36**)
- (4) Torque limiter section can be disassembled as drawn in **Fig. 37**.

Note: It is impossible to disassemble Torque limiter complete itself. Replace the old Torque limiter complete with the new one as a complete part.

Fig. 36

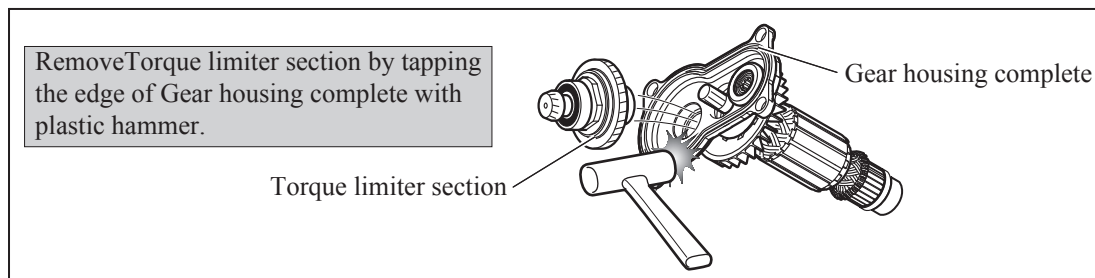
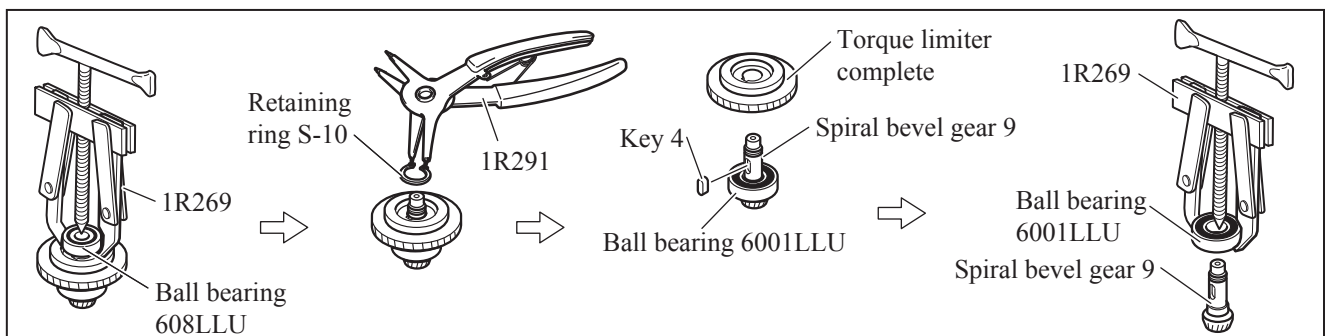

Fig. 37



ASSEMBLY

Do the reverse of disassembling steps.

► **Repair**

[3] DISASSEMBLY/ASSEMBLY

[3] -7. Crank Shaft

DISASSEMBLY

- (1) Remove Crank housing cover and Handle section from the Machine. (Fig. 18 /18A, 19 /19A, 20, 21, 22)
 - (2) Separate Gear housing complete from Crank housing complete as illustrated in Figs. 24 and 25.
 - (3) Disassemble Crank housing complete. (Figs. 28, 29, 31 and 32)
- Note:** No need to remove Link lever complete and Link plate section.
- (4) Remove Crank section from Crank housing complete using 1R238 and arbor press. (Fig. 38)
 - (5) The Crank section is disassembled as drawn in Figs. 39 and 40.

Fig. 38

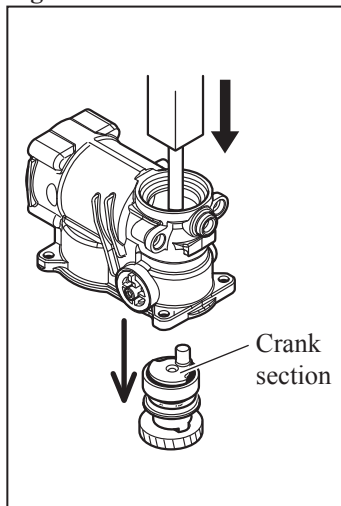

Fig. 39

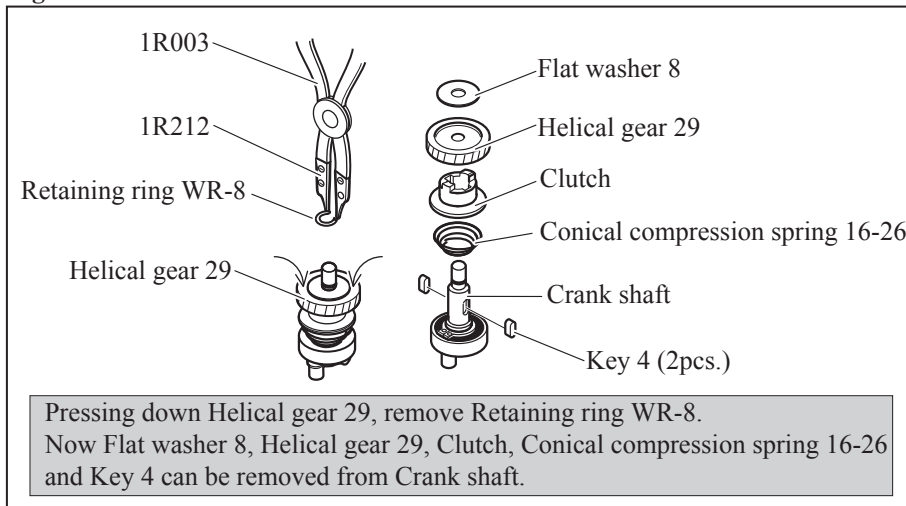
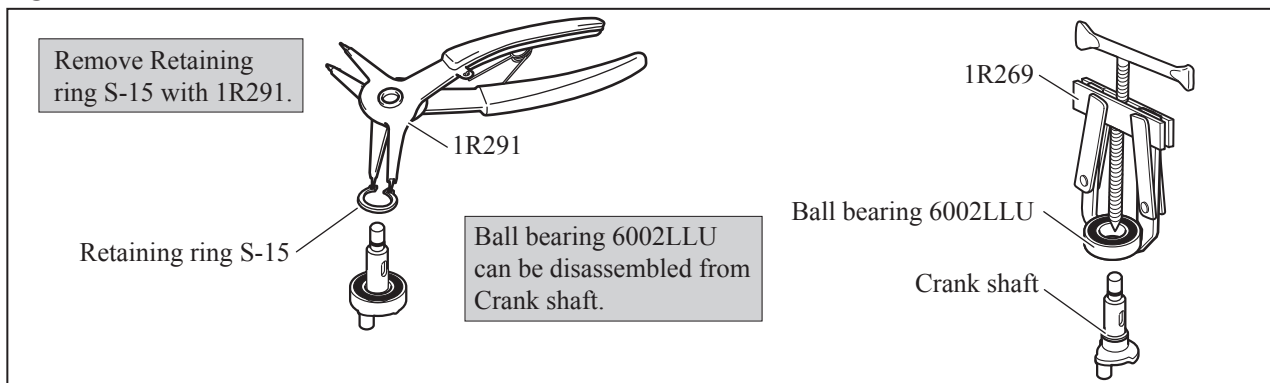

Fig. 40



ASSEMBLY

- Do the reverse of disassembling steps.
- Note:** Mount Conical compression spring 16-26 as drawn in Fig. 41.

Fig. 41

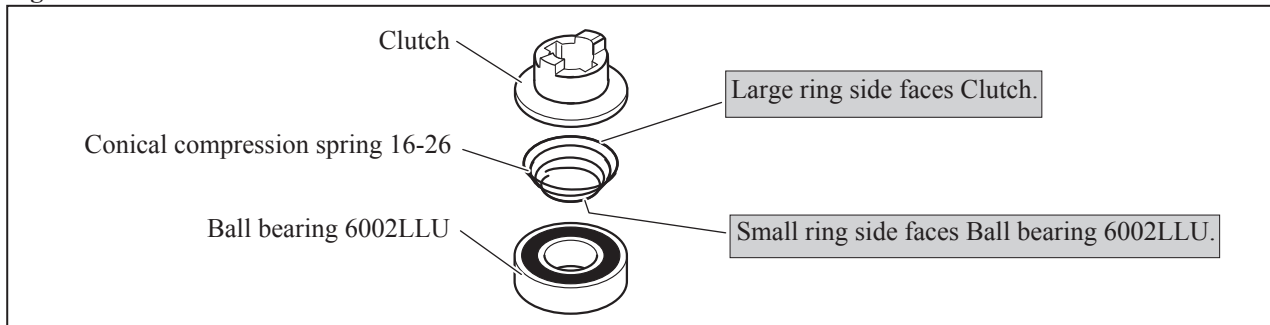

► **Repair**

[3] DISASSEMBLY/ASSEMBLY

[3] -8. Barrel section

DISASSEMBLY

- (1) Disassemble Tool holder section. (Figs. 3 and 4) And remove Crank housing cover. (Fig. 18/ 18A)
- (2) Remove Barrel complete from Crank housing complete. (Fig. 28)
- (3) Remove Ring spring 41 as drawn in Fig. 42. Now Barrel section can be disassembled as drawn in Fig. 43.

Fig. 42

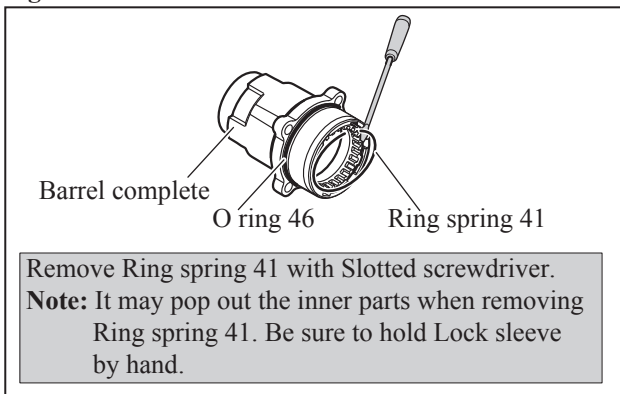
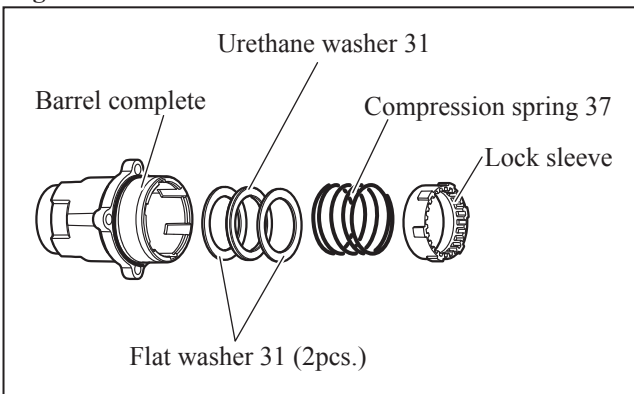

Fig. 43



- (4) In Barrel complete, Needle bearing 3012 and Oil seal 25 are installed as drawn in Fig. 44.
Apply 1R252 to Oil seal 25, and press it with Arbor press, and remove Needle bearing 3012 and oil seal 25 as drawn in Fig. 45.

Fig. 44

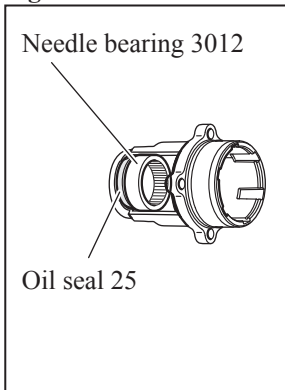
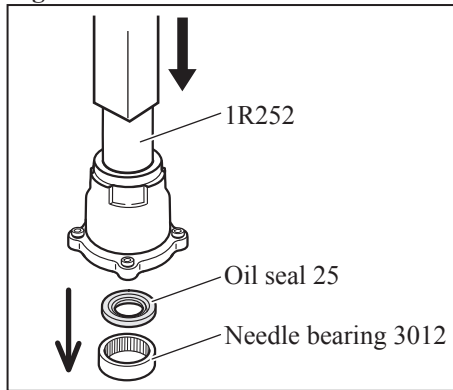

Fig. 45



ASSEMBLY

- (1) Assemble Oil seal 25 to Barrel complete as drawn in Figs. 46 and 47.

Fig. 46

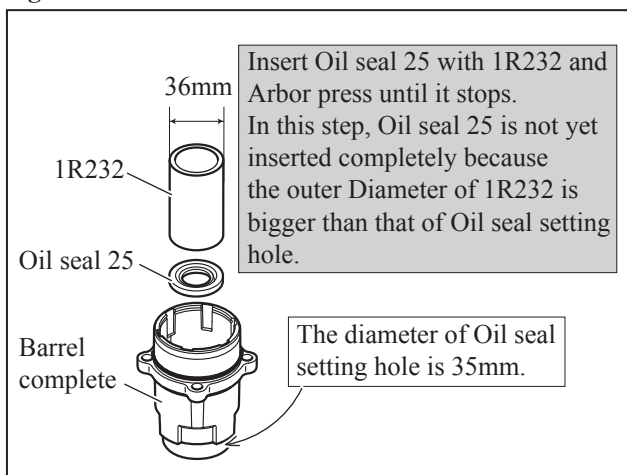
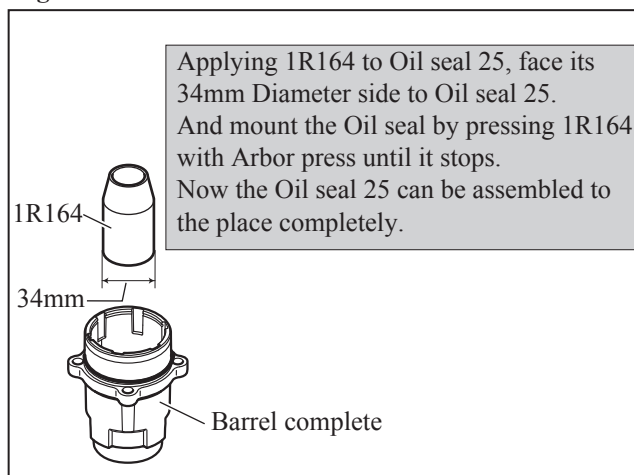

Fig. 47



► **Repair**

[3] DISASSEMBLY/ASSEMBLY

[3] -8. Barrel section

ASSEMBLY

- (2) Assemble Needle bearing 3012 and Flat washer 31 to Barrel complete as drawn in **Fig. 48**.
- (3) Secure Urethane washer 31, the other Flat washer 31, Compression spring 37 and Lock sleeve with Ring spring 41. (**Fig. 49**)

Fig. 48

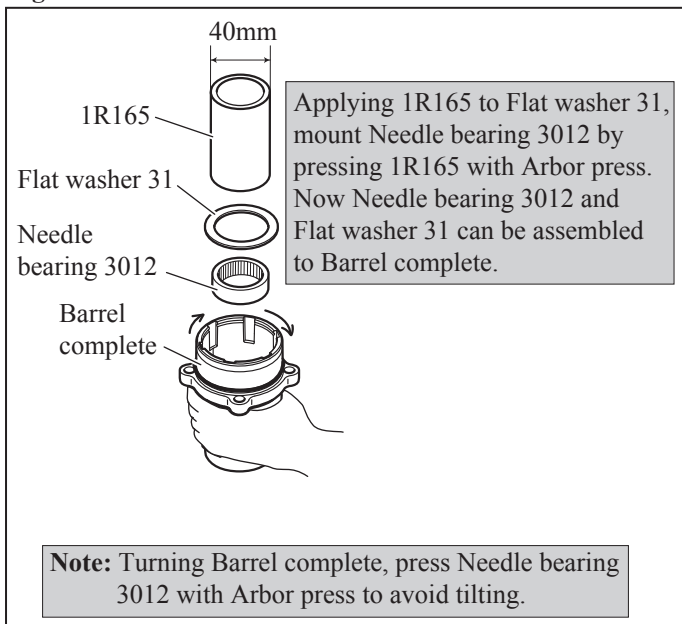
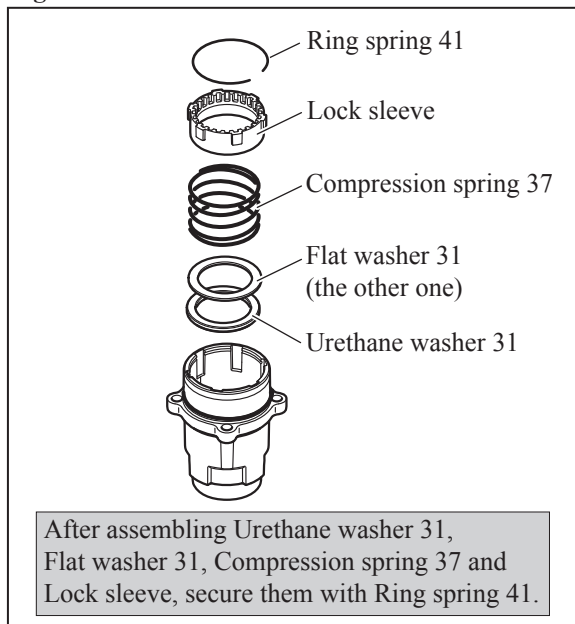

Fig. 49



[3] -9. Impact Bolt

DISASSEMBLY

- (1) Remove Barrel section and Tool holder (guide) complete from Crank housing complete. (**Fig. 28**)
- (2) Disassemble the Parts from Tool holder (guide) complete. (**Fig. 50**)

Fig. 50

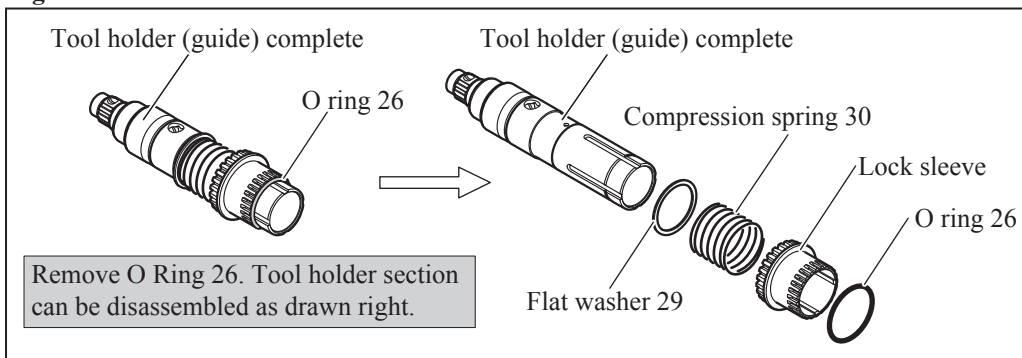

► **Repair**

[3] DISASSEMBLY/ASSEMBLY

[3] -9. Impact Bolt

DISASSEMBLY

(3) If the Cut portion of Ring spring 28 comes into your sight through the side hole of Tool holder (guide) complete, push the cut portion it to the out side of the hole. **(Fig. 51)**

Fig. 51

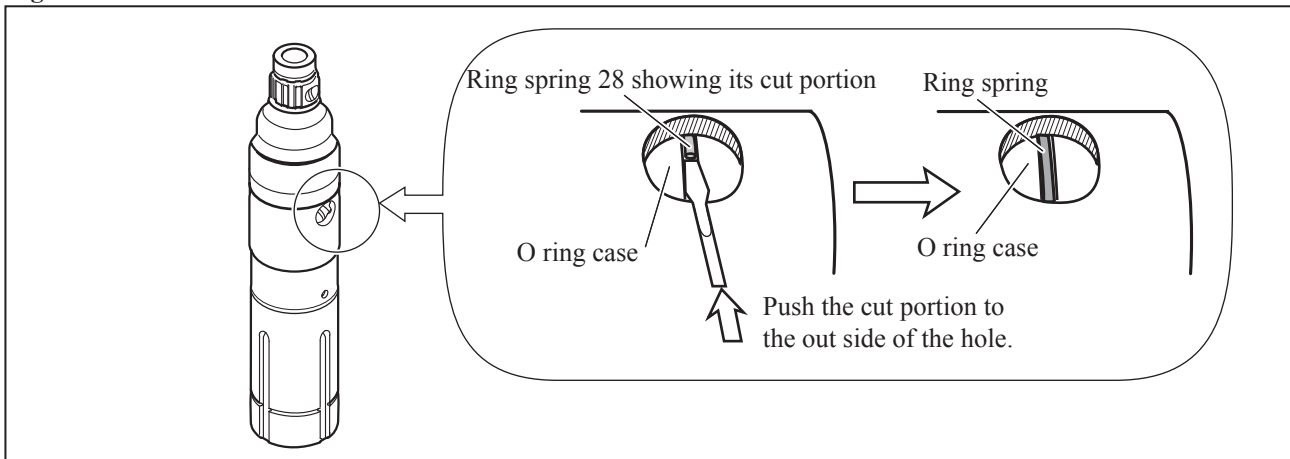

(4) Fixing Tool holder (guide) complete with 1R041 and vise, apply two slotted-screwdrivers to Ring spring 28 from both side holes. Strike two slotted-screwdrivers to Ring springs by turns and push out Ring spring 28 from the inner groove. **(Fig. 52)**

Fig. 52

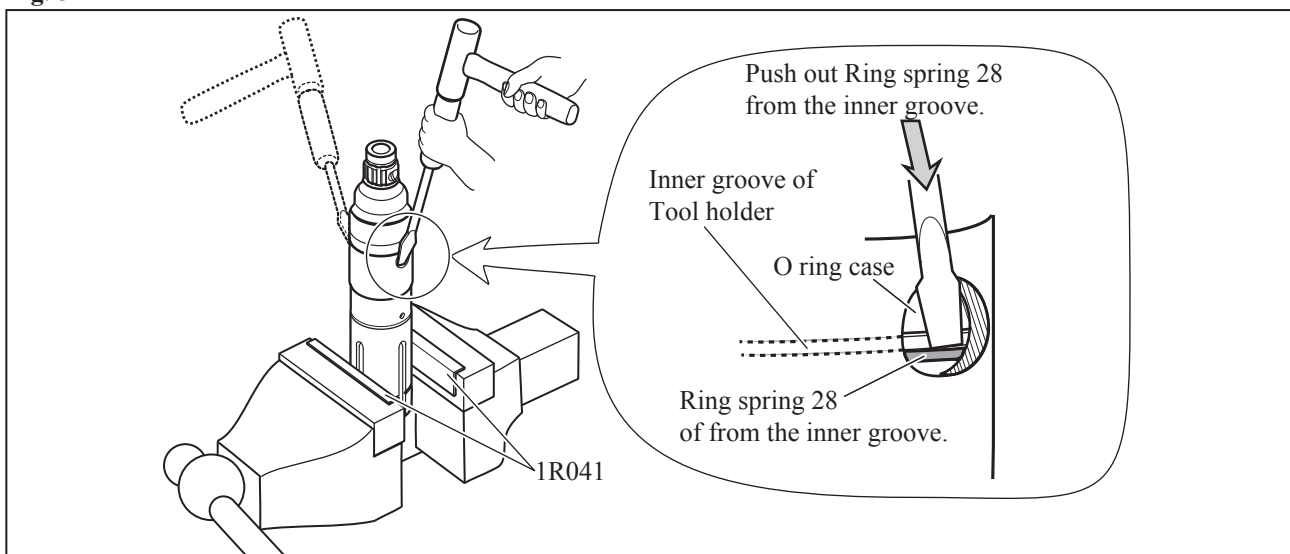

5) Push Ring spring 28 from both side holes, until it gets slanted in Tool holder (guide) complete for easy pulling off in the next step. **(Fig. 53)**

6) Pull off Ring spring 28 from Tool holder (guide) complete with Pliers. **(Fig. 54)**

Fig. 53

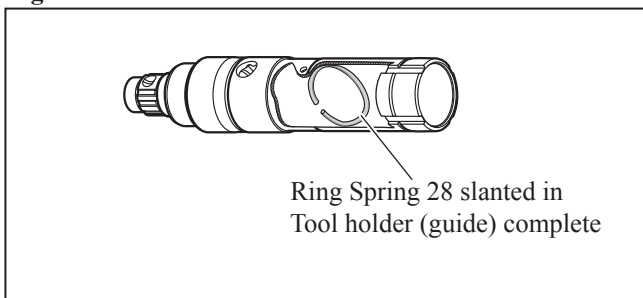
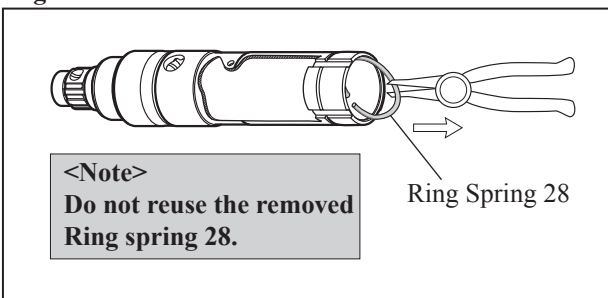

Fig. 54



► **Repair**

[3] DISASSEMBLY/ASSEMBLY

[3] -9. Impact Bolt

DISASSEMBLY

(7) The inner parts can be removed as drawn in **Figs. 55 and 56.**

Fig. 55

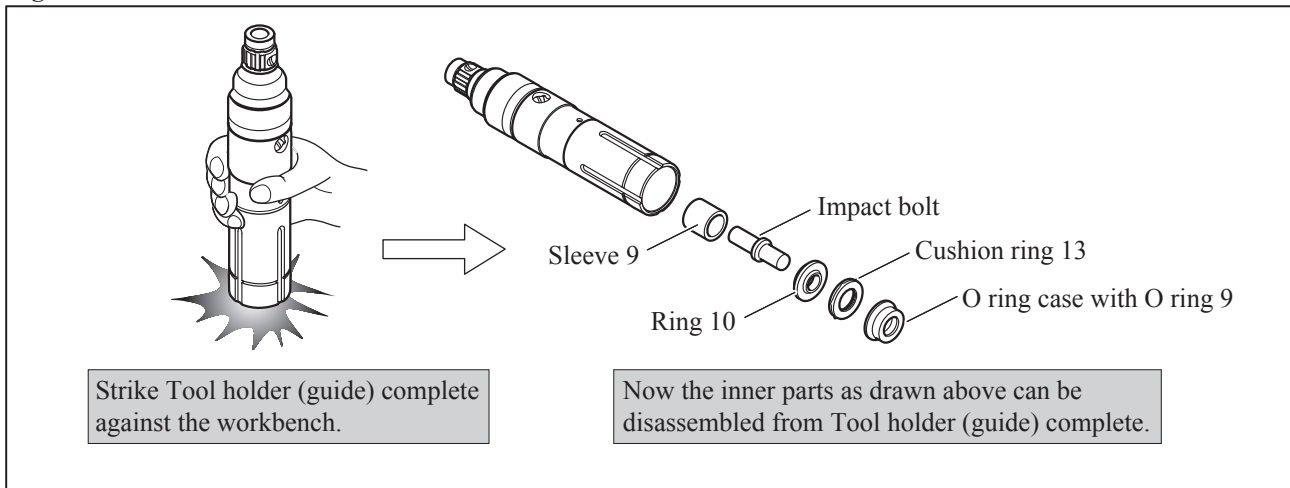
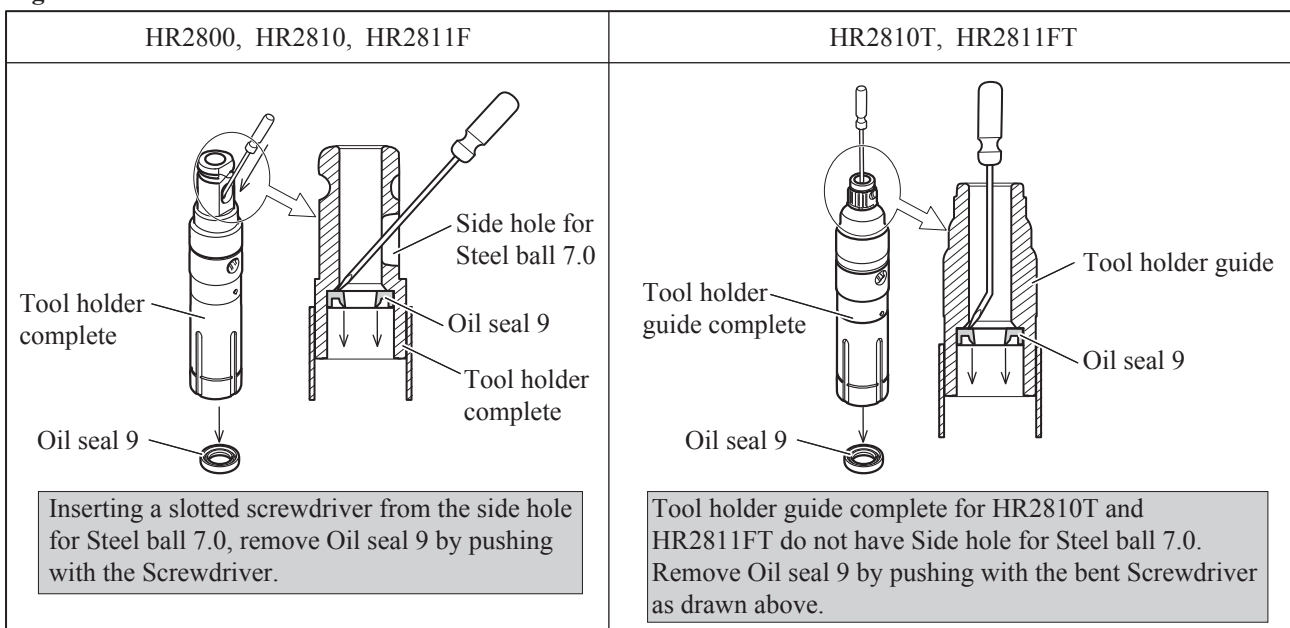

Fig. 56



ASSEMBLY

(1) Mount Oil seal 9 and the other inner parts as drawn in **Fig. 57.**

Fig. 57

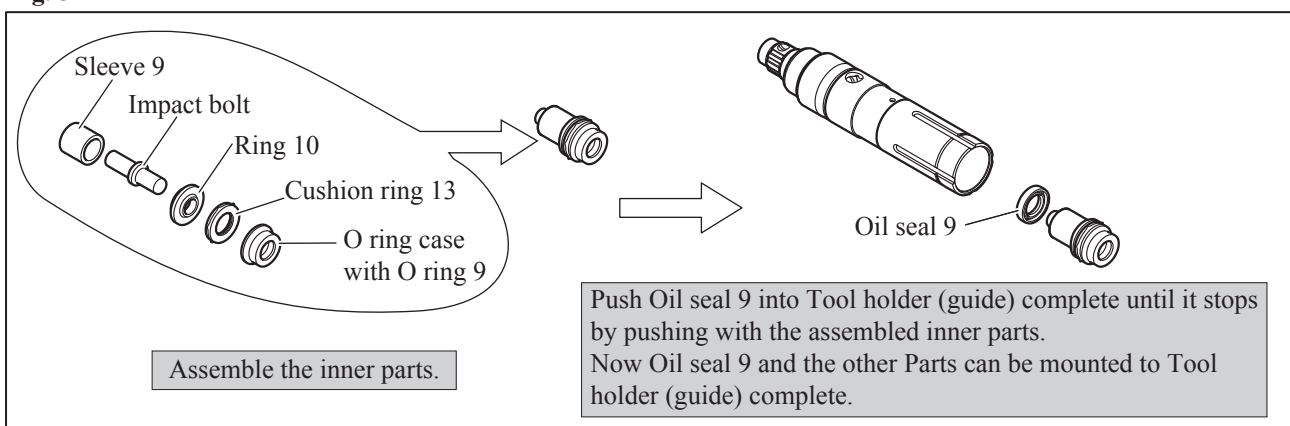

► **Repair**

[3] DISASSEMBLY/ASSEMBLY

[3] -9. Impact Bolt

ASSEMBLY

(2) Assemble Ring spring 28 by pressing Piston cylinder with Arbor press as drawn in **Fig. 58**.

Fig. 58

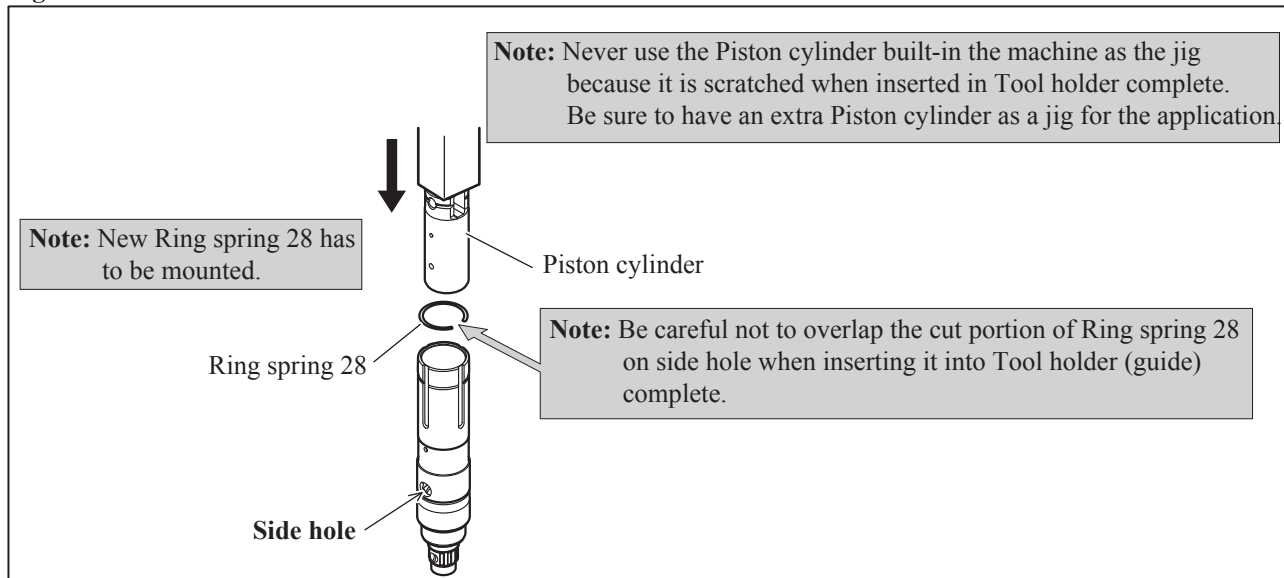

(3) Do the reverse of Disassembling steps. (Refer to **Fig. 50**.)

[3] -10. Fastening Torque of Screw and Bolt

Fasten the Bolts **illustrated in Fig. 66** with the Fastening Torque listed below.

Fig. 66

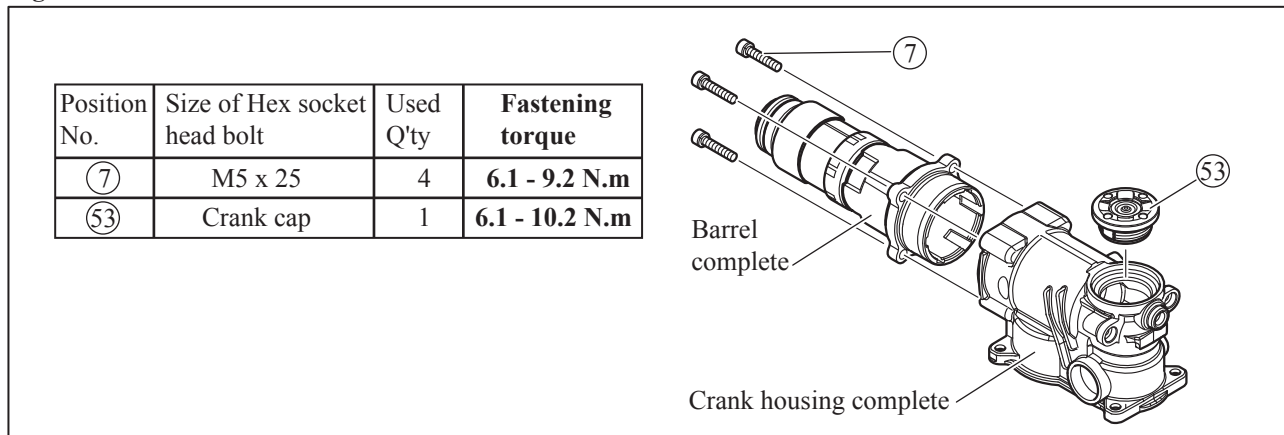

► Repair

[4] Maintenance

When replacing carbon brush, it is recommended to do the following maintenance at the same time for longer service life of the machine.

(1) Replace the parts listed below. (Fig. 67)

Position No.	Description	Position No.	Description
① ⑬①	Cap 35	③①	Ring spring 28
⑳① ⑬⑤	Steel ball 7.0	③⑧	O ring 16
⑳⑧	Cushion ring 13	⑬④①	Steel ball 6.0
⑳①	O ring 9		

Fig. 67

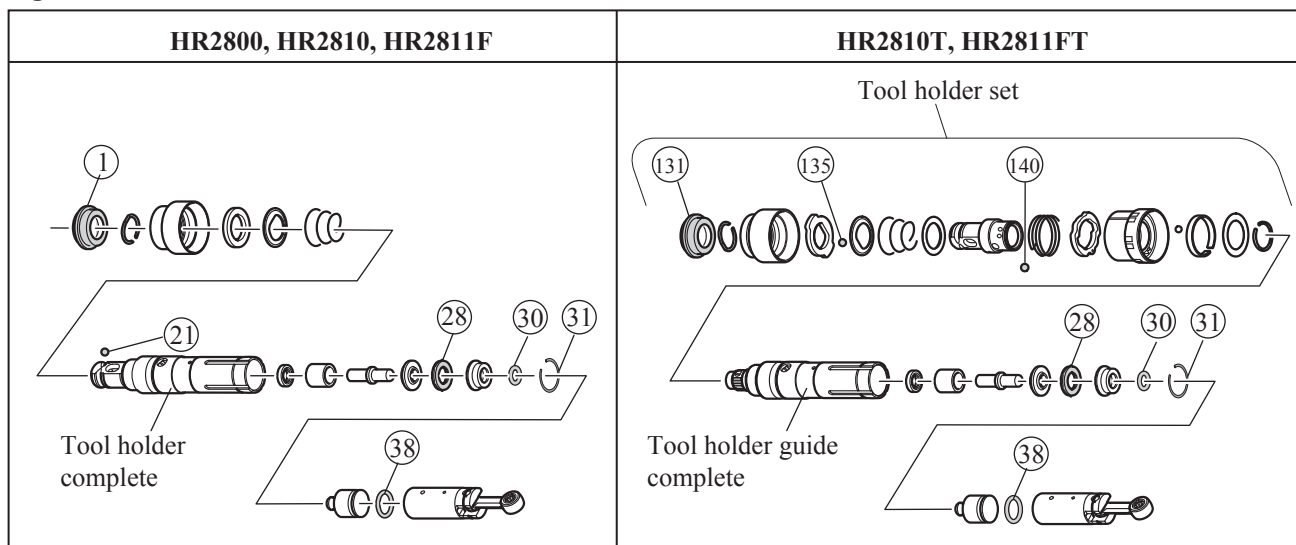

(2) Additionally apply approx. 60cc of Makita grease R No.00 to the inside of Crank housing complete.

► **Circuit diagram**

< HR2811F / HR2811FT with LED Job Light >

Fig. D-1

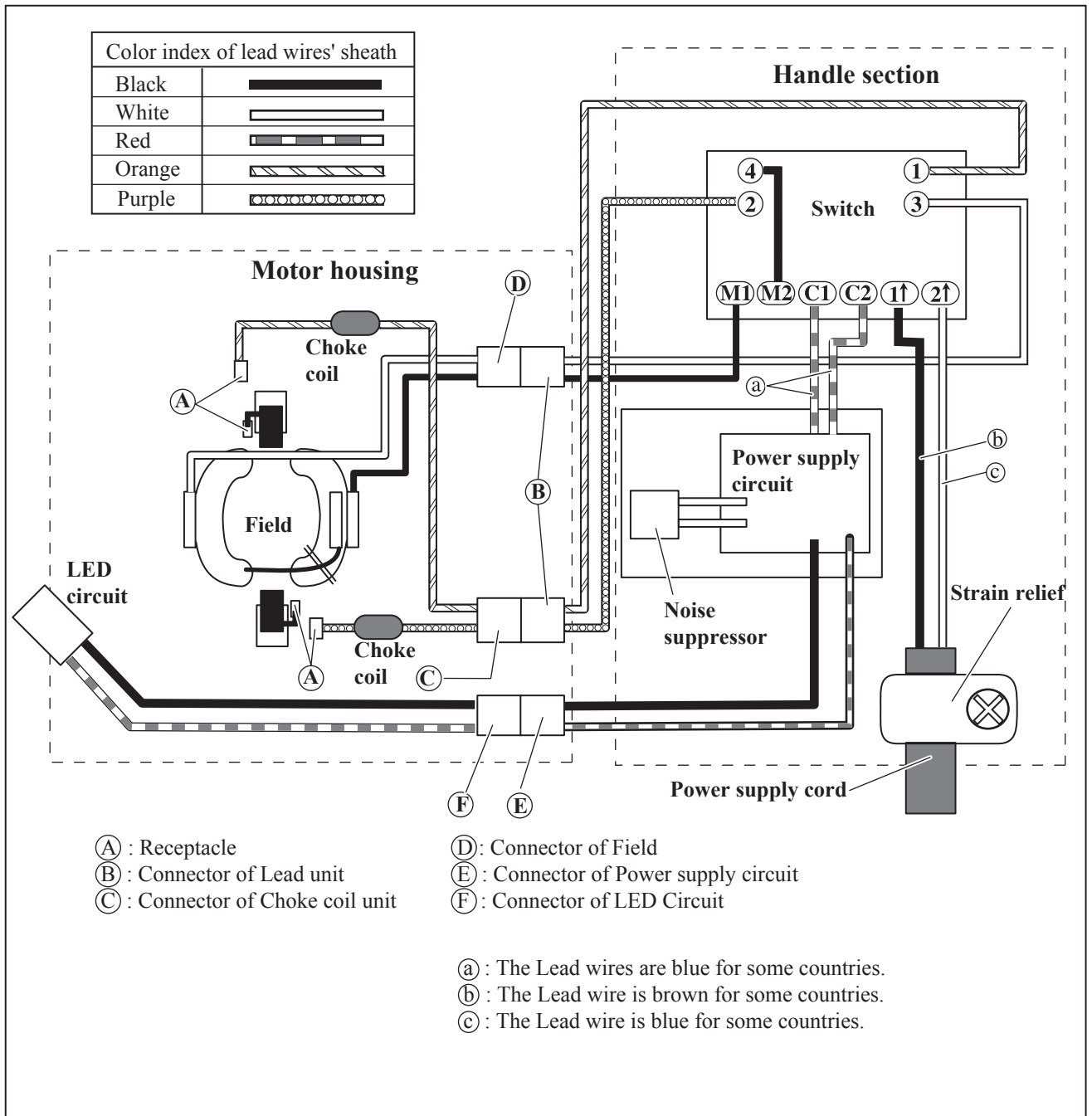

► **Wiring diagram**

< HR2811F / HR2811FT with LED Job Light >

Fig. D-2

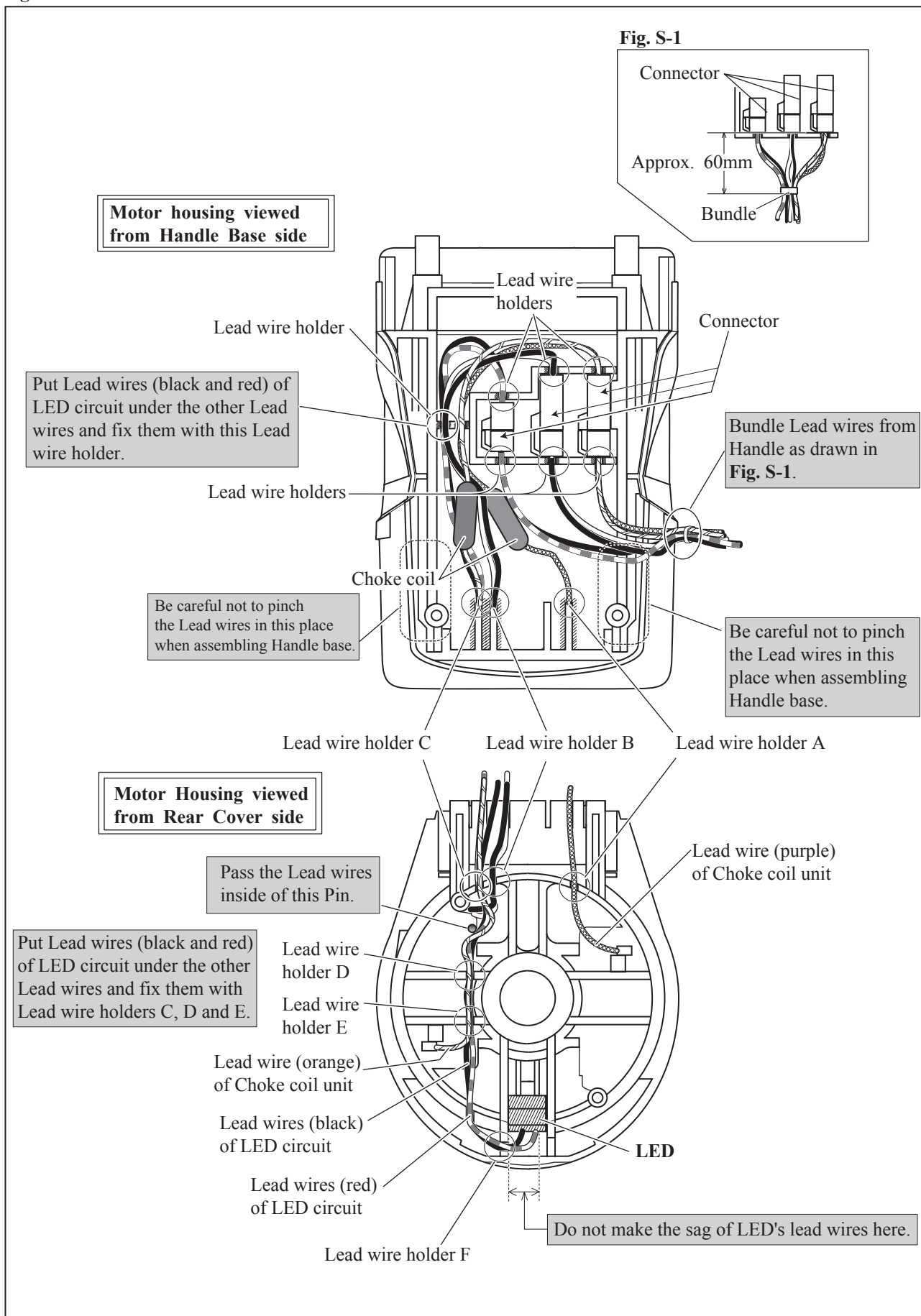

► **Wiring diagram**

< HR2811F / HR2811FT with LED Job Light >

Fig. D-3

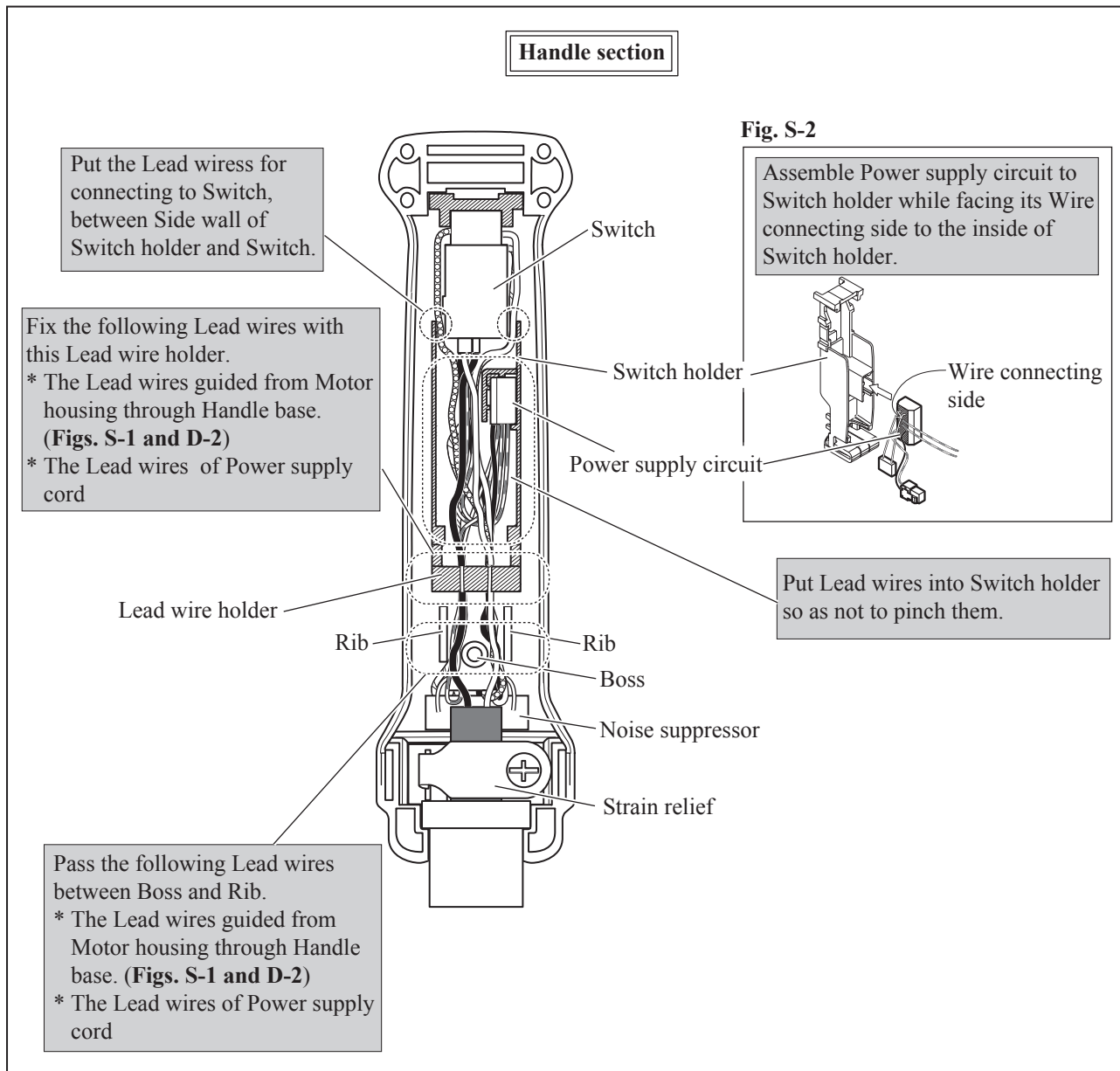

► **Circuit diagram**

< HR2800 / HR2810 / HR2810T without LED Job Light >

Fig. D-4

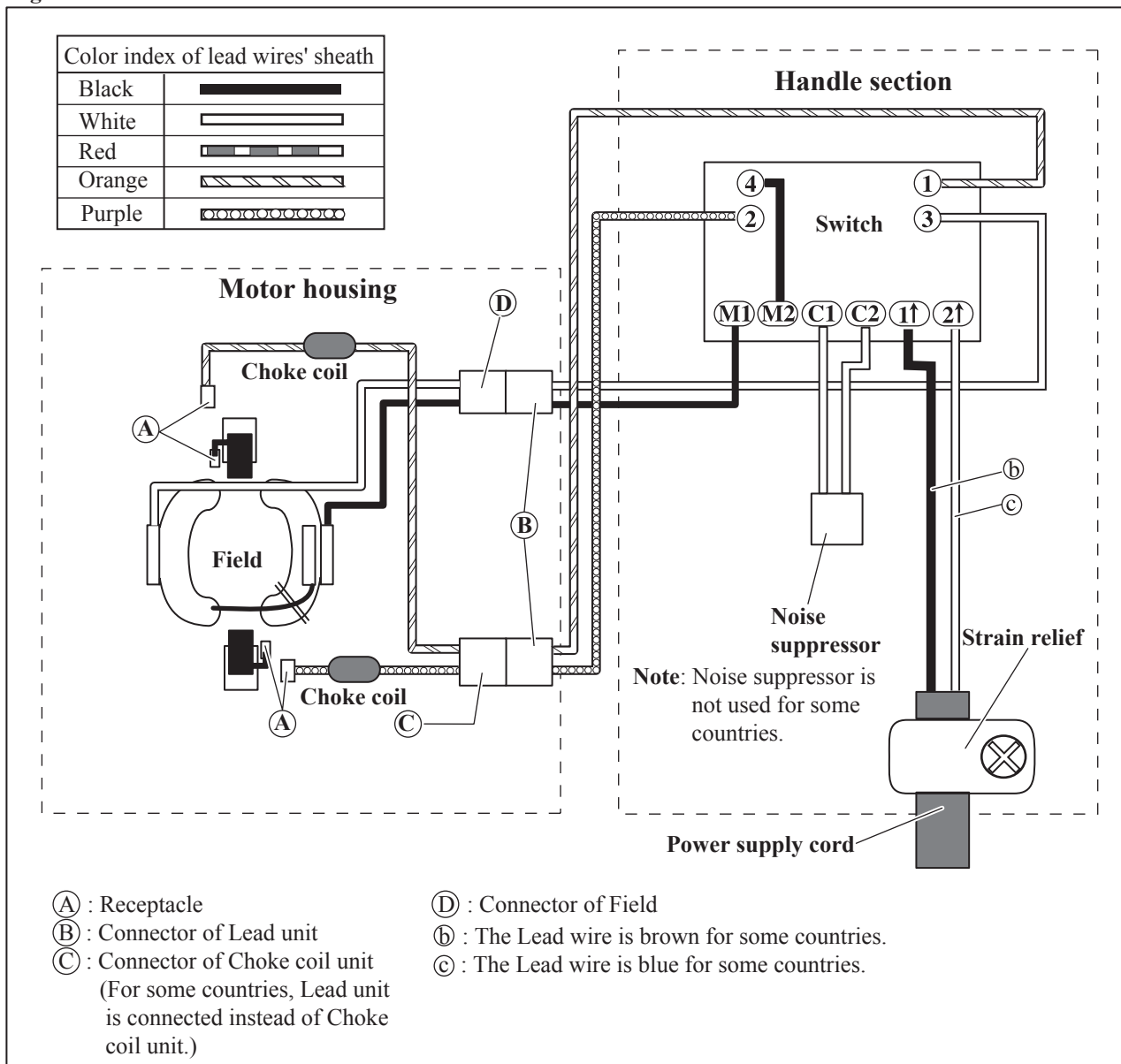

▶ Wiring diagram

<< HR2800 / HR2810 / HR2810T without LED Job Light >>

Fig. D-5

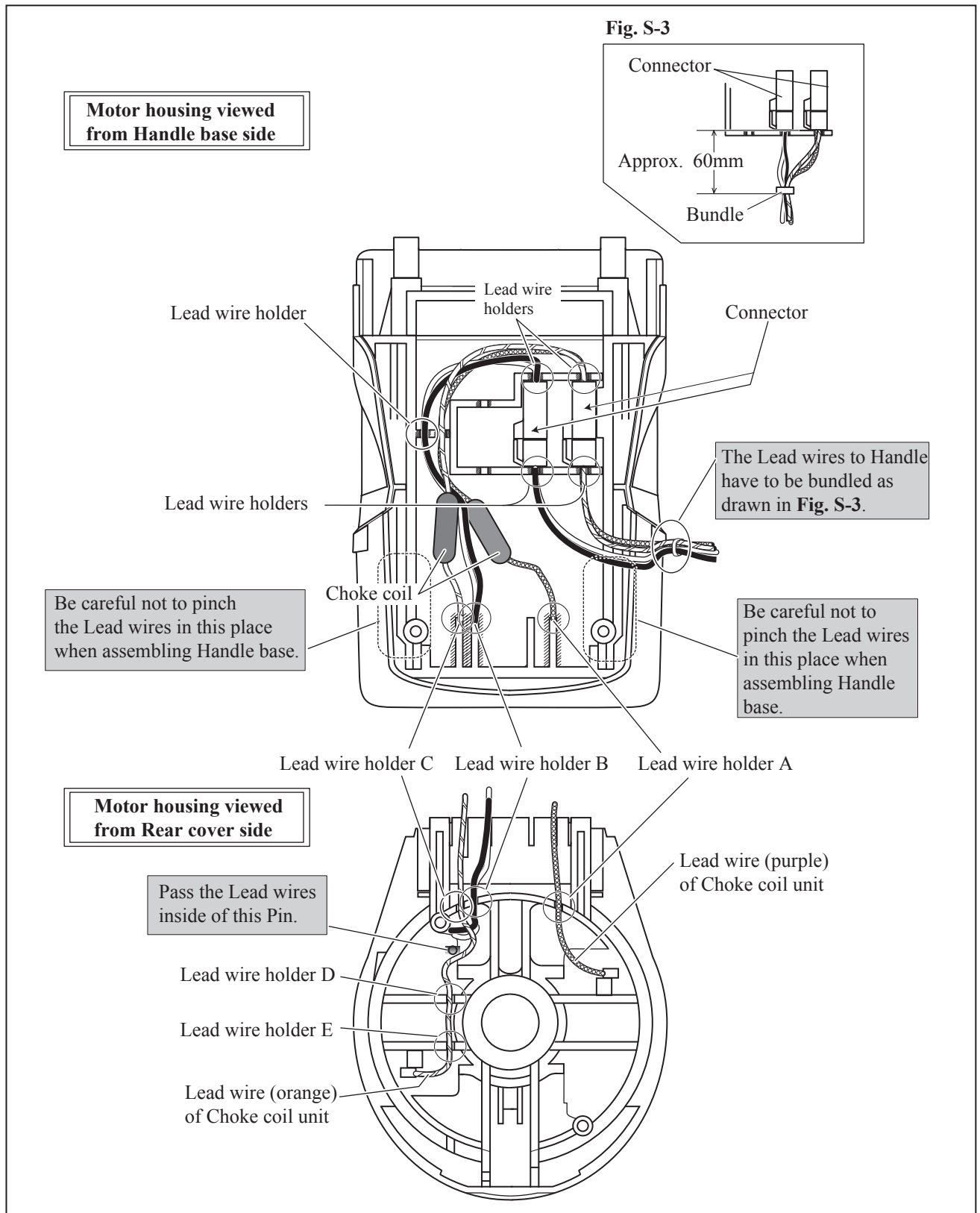

► **Wiring diagram**

< **HR2800 / HR2810 / HR2810T without LED Job Light** >

Fig. D-6

